

Sanitary Progressive Cavity Drum Pumps

SP-800DD SERIES

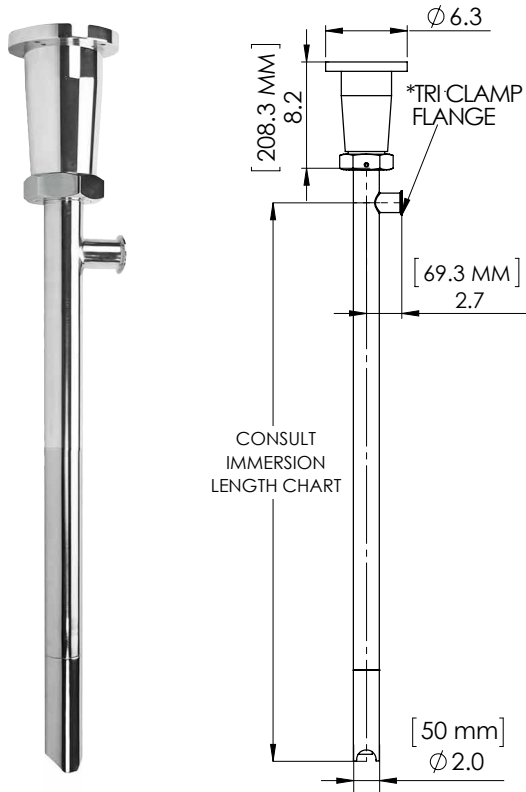

TUBE MODEL	ASSEMBLY	IMMERSION LENGTH	STATOR MATERIAL	SHIPPING WT lbs (kg)
SP-800DD-751FG-27	SS316	27" (700 mm)	Food Grade Buna	19.0 (8,6)
SP-800DD-751P-27	SS316	27" (700 mm)	PTFE	19.0 (8,6)
SP-800DD-752FG-27	SS316	32" (810 mm)	Food Grade Buna	21.0 (9,5)
SP-800DD-752P-27	SS316	32" (810 mm)	PTFE	21.0 (9,5)
SP-800DD-1851FG-27	SS316	34" (860 mm)	Food Grade Buna	24.0 (10,8)
SP-800DD-1851P-27	SS316	34" (860 mm)	PTFE	24.0 (10,8)
SP-800DD-751FG-39	SS316	39" (1000 mm)	Food Grade Buna	24.0 (10,8)
SP-800DD-751P-39	SS316	39" (1000 mm)	PTFE	24.0 (10,8)
SP-800DD-752FG-39	SS316	44" (1120 mm)	Food Grade Buna	25.0 (11,3)
SP-800DD-752P-39	SS316	44" (1120 mm)	PTFE	25.0 (11,3)
SP-800DD-1851FG-39	SS316	39" (1000 mm)	Food Grade Buna	23.0 (10,4)
SP-800DD-1851P-39	SS316	39" (1000 mm)	PTFE	23.0 (10,4)
SP-800DD-751FG-47	SS316	47" (1200 mm)	Food Grade Buna	25.0 (11,3)
SP-800DD-751P-47	SS316	47" (1200 mm)	PTFE	25.0 (11,3)
SP-800DD-752FG-47	SS316	52" (1320 mm)	Food Grade Buna	26.0 (11,8)
SP-800DD-752P-47	SS316	52" (1320 mm)	PTFE	26.0 (11,8)
SP-800DD-1851FG-47	SS316	47" (1200 mm)	Food Grade Buna	25.0 (11,3)
SP-800DD-1851P-47	SS316	47" (1200 mm)	PTFE	25.0 (11,3)

Technical Specifications

Design:.....Progressive Cavity / Positive Displacement
Discharge Port: 1.5" Tri-Clamp
 Available Options 1.25" (32 mm) or 1.5" (38 mm) Hose Barb*
Inlet Size:.....2" (51 mm)
Immersion Lengths: Carboys – 27" (700 mm)
 Drums – 39" (1000 mm)
 Tote Tanks – 47" (1200 mm)
Wetted Material:
 Tube & Rotor Assembly:316 Stainless Steel
 Stator Material:..... PTFE or White Buna
 Mechanical Seal:.....SiC/Italon®/SiC
Pump Finish:.....32 Ra
Motor Drives:.....TEFC, Washdown, Stainless Steel & Air

Maximum Viscosity:
 751 & 752 Series 100,000 cps (mPas)
 1851 Series..... 10,000 cps (mPas)
Maximum Flow Rate:
 1851 Series..... 12 GPM (45 LPM) based on water
 751 & 752 Series 7 GPM (26 LPM) based on water
Duty Cycle: Continuous
Maximum Discharge Pressure:
 751 & 1851 Series 87 psi (6 bar)
 752 Series..... 174 psi (12 bar)
Maximum Temperature:
 PTFE Stator 300° F (148° C)
 Buna Stator 185° F (85° C)
Maximum Solid Size:.....0.25" (6 mm)
Mounting Flange:..... B14/C140-160

*Hose Barb, O-Ring, Triclamp Not Included.

Sanitary Progressive Cavity Drum Pumps

SP-800DD SERIES

Bag Liner Series

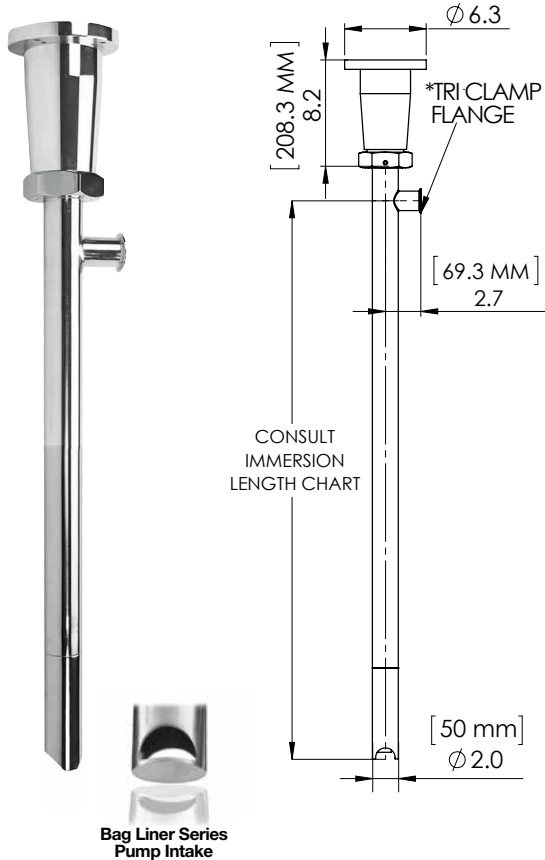

TUBE MODEL	ASSEMBLY	IMMERSION LENGTH	STATOR MATERIAL	SHIPPING WT lbs (kg)
SP-800DD-751FG-27-BL	SS316	27" (700 mm)	Food Grade Buna	19.0 (8,6)
SP-800DD-751P-27-BL	SS316	27" (700 mm)	PTFE	19.0 (8,6)
SP-800DD-752FG-27-BL	SS316	32" (810 mm)	Food Grade Buna	21.0 (9,5)
SP-800DD-752P-27-BL	SS316	32" (810 mm)	PTFE	21.0 (9,5)
SP-800DD-1851FG-27-BL	SS316	34" (860 mm)	Food Grade Buna	24.0 (10,8)
SP-800DD-1851P-27-BL	SS316	34" (860 mm)	PTFE	24.0 (10,8)
SP-800DD-751FG-39-BL	SS316	39" (1000 mm)	Food Grade Buna	24.0 (10,8)
SP-800DD-751P-39-BL	SS316	39" (1000 mm)	PTFE	24.0 (10,8)
SP-800DD-752FG-39-BL	SS316	44" (1120 mm)	Food Grade Buna	25.0 (11,3)
SP-800DD-752P-39-BL	SS316	44" (1120 mm)	PTFE	25.0 (11,3)
SP-800DD-1851FG-39-BL	SS316	39" (1000 mm)	Food Grade Buna	23.0 (10,4)
SP-800DD-1851P-39-BL	SS316	39" (1000 mm)	PTFE	23.0 (10,4)
SP-800DD-751FG-47-BL	SS316	47" (1200 mm)	Food Grade Buna	25.0 (11,3)
SP-800DD-751P-47-BL	SS316	47" (1200 mm)	PTFE	25.0 (11,3)
SP-800DD-752FG-47-BL	SS316	52" (1320 mm)	Food Grade Buna	26.0 (11,8)
SP-800DD-752P-47-BL	SS316	52" (1320 mm)	PTFE	26.0 (11,8)
SP-800DD-1851FG-47-BL	SS316	47" (1200 mm)	Food Grade Buna	25.0 (11,3)
SP-800DD-1851P-47-BL	SS316	47" (1200 mm)	PTFE	25.0 (11,3)

Technical Specifications

Design:.....Progressive Cavity / Positive Displacement
Discharge Port: 1.5" Tri-Clamp
 Available Options 1.25" (32 mm) or 1.5" (38 mm) Hose Barb*
Inlet Size:.....2" (51 mm)
Immersion Lengths: Carboys – 27" (700 mm)
 Drums – 39" (1000 mm)
 Tote Tanks – 47" (1200 mm)
Wetted Material:
 Tube & Rotor Assembly:316 Stainless Steel
 Stator Material:..... PTFE or White Buna
 Mechanical Seal:.....SiC/Viton®/SiC
Pump Finish:......32 Ra
Motor Drives:..... TEFC, Washdown, Stainless Steel & Air

Maximum Viscosity:
 751 & 752 Series 100,000 cps (mPas)
 1851 Series..... 10,000 cps (mPas)
Maximum Flow Rate:
 1851 Series..... 12 GPM (45 LPM) *based on water*
 751 & 752 Series 7 GPM (26 LPM) *based on water*
Duty Cycle:..... Continuous
Maximum Discharge Pressure:
 751 & 1851 Series 87 psi (6 bar)
 752 Series..... 174 psi (12 bar)
Maximum Temperature:
 PTFE Stator 300° F (148° C)
 Buna Stator 185° F (85° C)
Maximum Solid Size:.....0.25" (6 mm)
Mounting Flange:..... B14/C140-160
Bag Liner Series:Optional pump intake design
 available for applications with hygienic liners

*Hose Barb, O-Ring, Triclamp Not Included.

Sanitary Progressive Cavity Drum Pumps

SP-80000 SERIES Performance Curves

751 Series Pumps

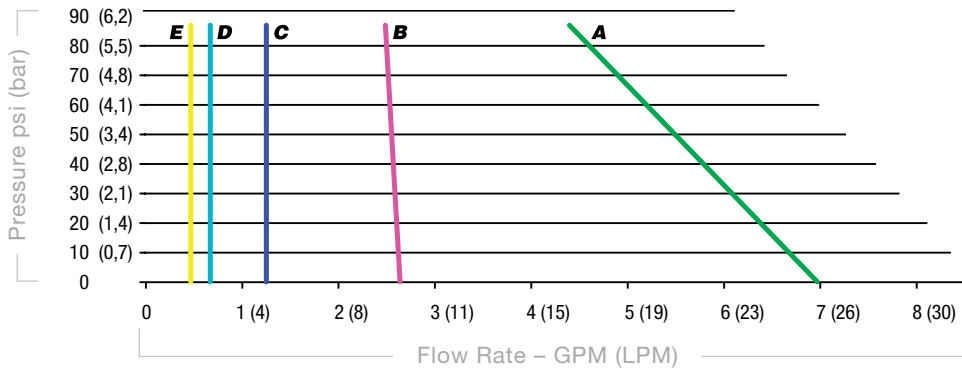

Viscosity cps (mPas)	Electric Motor	Air Motor
A 1	SP-502	SP-A4
B 10,000	SP-502	SP-A4
C 30,000	SP-512	SP-A6
D 60,000	SP-512	SP-A6
E 100,000	SP-522	SP-A8

752 Series Pumps

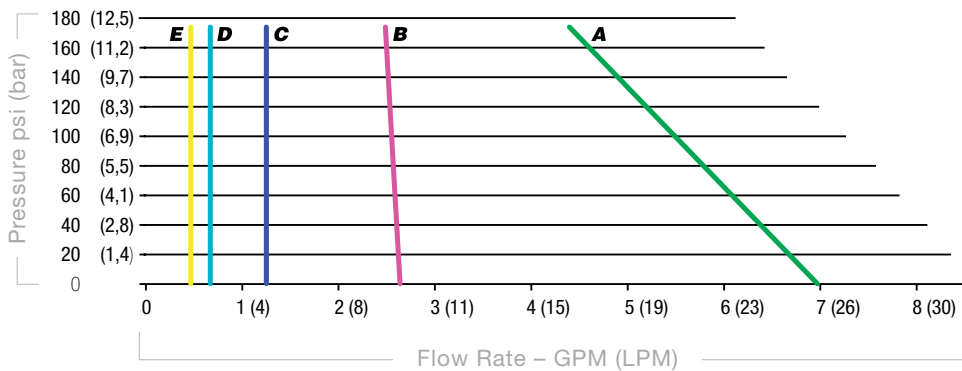

Viscosity cps (mPas)	Electric Motor	Air Motor
A 1	SP-502	SP-A4
B 10,000	SP-502	SP-A4
C 30,000	SP-512	SP-A6
D 60,000	SP-512	SP-A6
E 100,000	SP-522	SP-A8

1851 Series Pumps

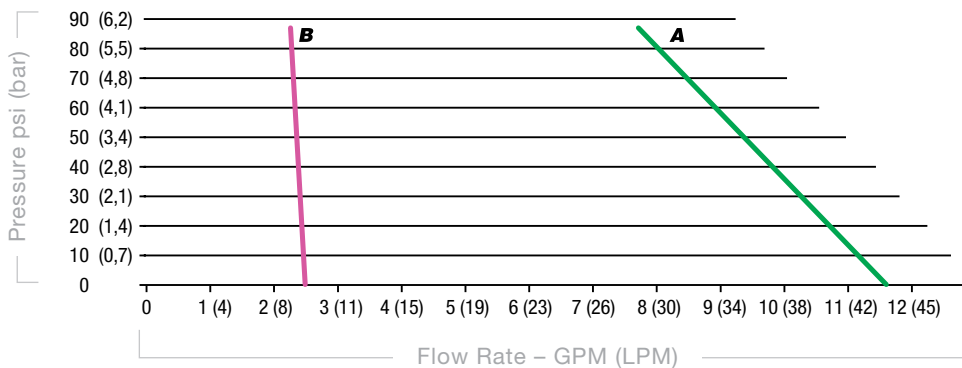

Viscosity cps (mPas)	Electric Motor	Air Motor
A 1	SP-502	SP-A4
B 10,000	SP-502	SP-A4



CSI 417.831.1411
csidesigns.com

STANDARD
Pumps, Inc.