

Sanitary Hydroheater® for Sanitary Applications

Sanitary Hydroheaters are self-draining from multiple orientations. The unit can be easily disassembled for CIP, and the steam and liquid inlets can rotate 360°. The unit will drain in a vertical position or, if horizontal, with steam and liquid inlets downward, angled below horizontal plane.

Hydroheaters ensure quick heating with no warm-up time needed and 100% thermal efficiency, because both latent and sensible heat of the steam are used. The unique design eliminates hammering normally associated with other direct injection heating devices.

Sanitary Hydroheaters are designed specifically for the food and beverage, cheese and dairy, cosmetics, and pharmaceutical processing industries.

In addition, Hydro-Thermal® manufactures complete heating systems. Contact us for more information about our Sanitary Engineered Heating Systems (EHS).

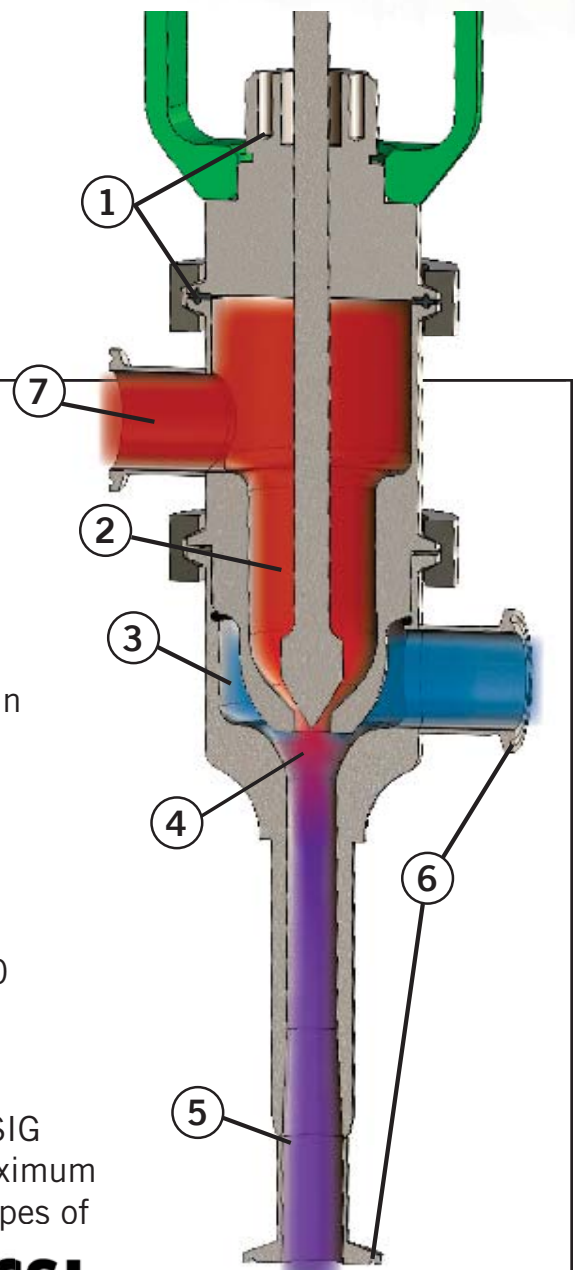
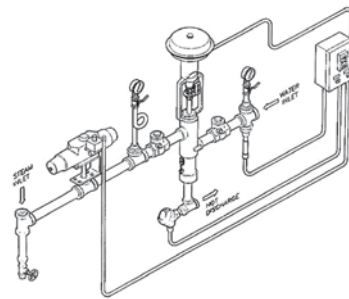

1. Packing and gasket meet USDA/3A requirements.
2. Internal steam flow modulation eliminates the need for external steam control valves.
3. Clean-Flow design prevents plugging of product.
4. High velocity steam provides efficient heat transfer in addition to self-cleaning of internal surfaces.
5. Packing and gasket meet USDA/3A requirements.
6. Handles a wide range of liquids and flow rates. Six different sizes (for 0.5", 1.0", 1.5", 2.0", 2.5" connections) can accommodate flow rates up to 180 gallons a minute. Standard Tri-Clamp connections I-Line connections available on request.
7. Accommodates steam supply pressure up to 150 PSIG and steam flow rates up to 13,000 lbs/hr with a maximum temperature rise to 200°F. Heats water and many types of liquid mixtures.

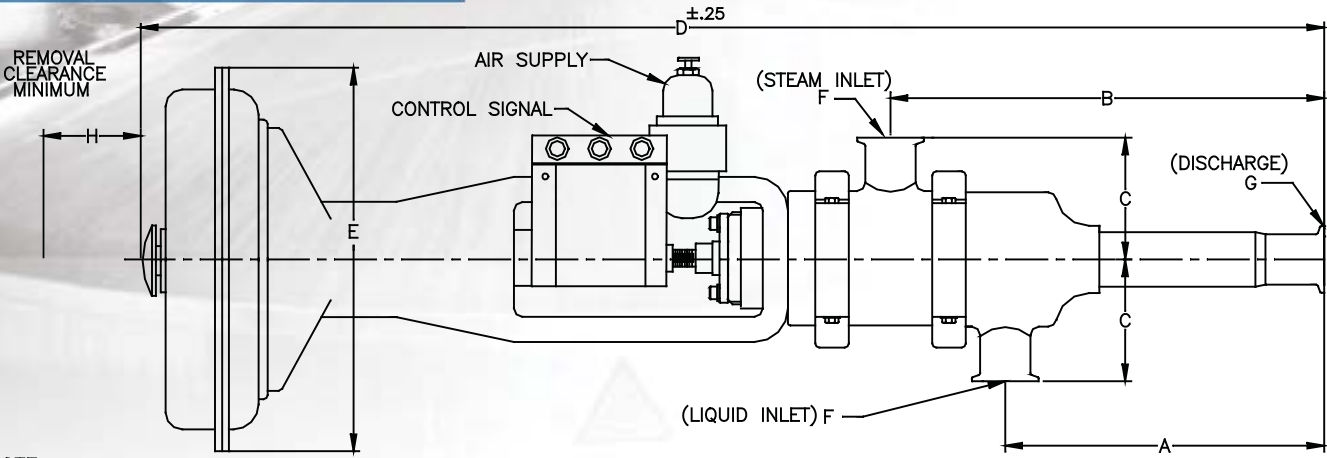

NOTE:
ALL DIMENSIONS IN INCHES.
STANDARD PIPING TOLERANCES APPLY.

(SHOWN WITH OPTIONAL POSITIONER)

MODEL	A	B	C	D	E	F	G	H	APPROX. WT.
A204/304	2.87"	5.37"	2.64"	16.26"	ø8.50"	ø.50"	ø.50"	10"	20 LBS.
A206	6.79"	10.29"	3.10"	32.18"	ø11.38"	ø1.00"	ø1.00"	10"	45 LBS.
A207/307	8.15"	11.65"	2.90"	33.54"	ø11.38"	ø1.50"	ø1.00"	10"	50 LBS.
A208	9.36"	12.86"	3.63"	42.24"	ø13.13"	ø1.50"	ø1.50"	10"	85 LBS.
A209	11.30"	15.30"	3.64"	44.93"	ø13.13"	ø2.00"	ø1.50"	10"	95 LBS.
A210	14.00"	19.47"	5.00"	53.89"	ø16.00"	ø2.50"	ø2.50"	10"	125 LBS.

Standard Construction

Material

Head

Stainless Steel 316L

Product Contact Surfaces

Stainless Steel 316L

Stem

Stainless Steel ASTM-A564 17-4PH

Other materials available per application
or upon request

Connections

Standard Tri-Clamp®

I-Line available on request.

Standard Actuators

Utilizes a Fisher reverse-acting diaphragm actuator ("fail close"). Generally coupled with a filter/regulator and a Fisher DVC 2000 or a DVC 6200 positioner that converts a 4-20 mA DC input signal to pneumatic output signal to the actuator.

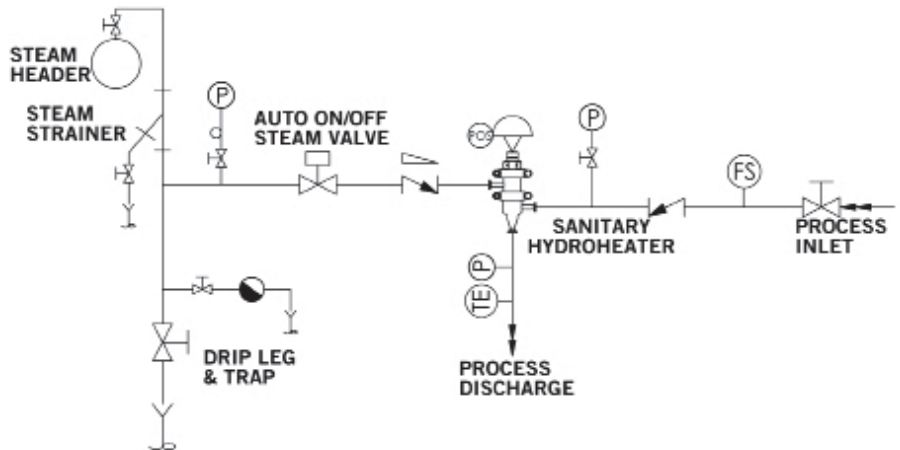

Ratings

150 PSIG at 400 degrees F design, temperature ratings based on material.

Specifications may change without notice.