

Instruction Manual

LKB Automatic or Manual Butterfly Valve and LKB-LP Low Pressure Butterfly Valve

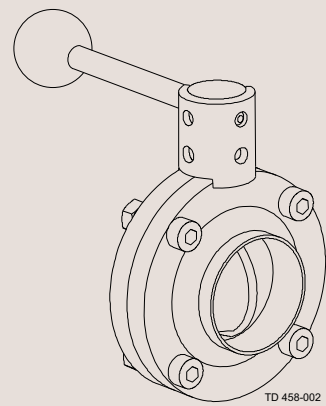
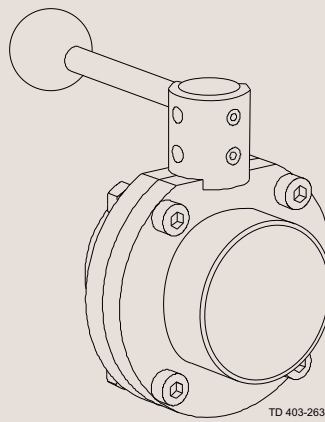
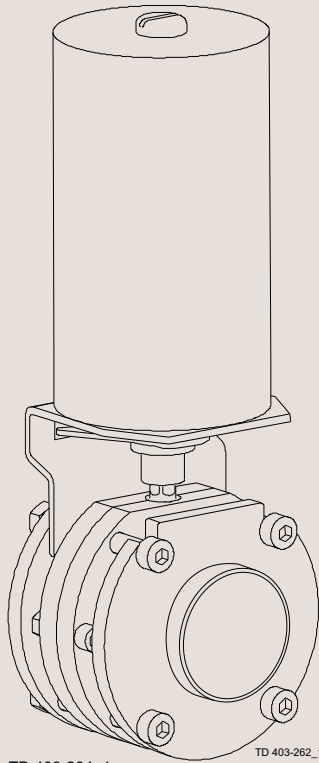

ESE02446-EN19 2021-01

Original manual



CSI

CONTACT CSI FOR MORE INFORMATION | CSIDESIGNS.COM | SALES@CSIDESIGNS.COM | 417.831.1411

Table of contents

The information herein is correct at the time of issue but may be subject to change without prior notice

1. CE Declaration of Incorporation for Machinery	5
2. Safety	6
2.1. Important information	6
2.2. Warning signs	6
2.3. Safety precautions	7
3. Installation	8
3.1. Unpacking/delivery	8
3.2. General installation	9
3.3. Welding	11
3.4. Fitting actuator/bracket/handle on the valve (optional extras)	12
3.5. Recycling information	13
4. Operation	14
4.1. Operation	14
4.2. Troubleshooting	15
4.3. Recommended cleaning	16
5. Maintenance	17
5.1. General maintenance	17
5.2. Dismantling of valve - LKB/LKB-2/LKB-LP	19
5.3. Assembly of valve - LKB/LKB-2/LKB-LP	20
5.4. Dismantling of valve - LKB-F	22
5.5. Assembly of valve - LKB-F	23
5.6. Dismantling of actuator	24
5.7. Assembly of actuator	25
6. Technical data	26
6.1. Technical data	26
7. Parts list and service kits	28
7.1. LKB, LKB-2, LKB-F Butterfly valves, drawings	28
7.2. LKB-LP Butterfly valve, drawing	29
7.3. LKLA and LKLA-T actuators Ø85 mm, drawings	30
7.4. LKLA and LKLA-T actuators Ø133 mm, drawings	33
7.5. LKB Butterfly valve, ISO	34
7.6. LKB-F Butterfly valves, ISO	36
7.7. LKB-F Butterfly valves, DIN	38
7.8. LKB-2 Butterfly valves	40
7.9. LKB-LP Butterfly valve	42
7.10. LKLA ø85 mm (NO/NC)	44
7.11. LKLA ø85 mm (A/A)	46
7.12. LKLA DN 125-150 ø85 mm (A/A)	48
7.13. LKLA ø133 mm (NO/NC)	50
7.14. LKLA ø133 mm (A/A)	52
7.15. LKLA-T ø85 mm (NO/NC)	54
7.16. LKLA-T ø85 mm (A/A)	56
7.17. LKLA-T DN 125-150 ø85 mm (A/A)	58
7.18. LKLA-T ø133 mm (NO/NC)	60
7.19. LKLA-T ø133 mm (A/A)	62

Table of contents

The information herein is correct at the time of issue but may be subject to change without prior notice

7.20. LKB lockable multiposition handle for valve	64
7.21. LKB handle 1.1 for butterfly valve	66
7.22. Handle 1.1 for indication unit	68

1 CE Declaration of Incorporation for Machinery

Revision of Declaration of Conformity 2013-12-03

The Designated Company

Alfa Laval Kolding A/S
Company Name

Albuen 31, DK-6000 Kolding, Denmark
Address

+45 79 32 22 00
Phone No.

hereby declare that

Valve actuator
Designation

LKLA NC, LKLA NO, LKLA A/A, LKLA-T NO, LKLA-T NC, LKLA-T A/A
Type

is in conformity with the following directive with amendments:

- Machinery Directive 2006/42/EC

The person authorised to compile the technical file is the signer of this document

Global Product Quality Manager
Pumps, Valves, Fittings and Tank Equipment
Title

Lars Kruse Andersen
Name

Kolding
Place

2016-06-01
Date

Signature



2 Safety

*Unsafe practices and other important information are highlighted in this manual.
Warnings are emphasized by means of special signs.*

2.1 Important information

Always read the manual before using the valve!

WARNING

Indicates that special procedures **must** be followed to avoid serious personal injury.

CAUTION

Indicates that special procedures **must** be followed to avoid damage to the valve.

NOTE

Indicates important information to simplify or clarify procedures.

2.2 Warning signs

General warning:



Caustic agents:



All warnings in the manual are summarised on this page.

"Mushrooms" = Fastening connections on the end cap.

Pay special attention to the instructions below so that severe personal injury and/or damage to the valve are avoided.

2.3 Safety precautions

Installation

Always read the technical data thoroughly (See chapter 6 Technical data).

Always release compressed air after use.

Never touch the coupling between the valve body and the actuator if compressed air is supplied to the actuator.



Operation

Always read the technical data thoroughly (See chapter 6 Technical data).

Never touch the valve or the pipelines when processing hot liquids or when sterilising.

Never touch the coupling between the valve body and the actuator if compressed air is supplied to the actuator.



Always handle lye and acid with great care.



Maintenance

Always observe the technical data thoroughly (See chapter 6 Technical data)

Always release compressed air after use.

Never service the valve when it is hot.

The valve/actuator and the pipelines must **never** be pressurised when servicing the valve/actuator.



Never stick your fingers through the valve ports if the actuator is supplied with compressed air.

Never touch the coupling between the valve body and the actuator if compressed air is supplied to the actuator.

The actuator springs are **not** caged (ø85 mm, NC/NO).

Never use compressed air for removing the end caps of the actuator.

Always fit the end cap with the "mushrooms" turned outwards and position it correctly before supplying compressed air to the actuator.

Always use Alfa Laval genuine spare parts. The warranty of Alfa Laval products is dependent on the use of Alfa Laval genuine spare parts.

Transportation

Always ensure that compressed air is released.

Always ensure that all connections are disconnected before attempting to remove the valve from the installation.

Always drain liquid out of valves before transportation.

Always used predesigned lifting points if defined.

Always secure sufficient fixing of the valve during transportation - if specially designed packaging material is available, it must be used.

3 Installation

The instruction manual is part of the delivery. Read the instructions carefully.

The items refer to parts list and service kits sections.

The valve is supplied as separate parts as standard (for welding)

The valve is assembled before delivery, if it is supplied with fittings (LKB/LKB-2)

3.1 Unpacking/delivery

Step 1

CAUTION

Alfa Laval cannot be held responsible for incorrect unpacking.

Check the delivery:

1. Complete valve (see Step 2).
2. Complete actuator, if supplied (see Step 3).
3. Bracket for actuator, if supplied (see Step 3).
4. Complete handle, if supplied.
5. Delivery note.
6. Instruction manual.

Step 2

Standard delivery of valve parts:

1. Two valve body halves (1).
2. Valve disc (2) fitted in seal ring (5).
3. Two bushes (3, 4) fitted on the disc stem.
4. A set of screws and nuts (6).
5. Two flanges (7) and two flange seal rings (8), (LKB-F).

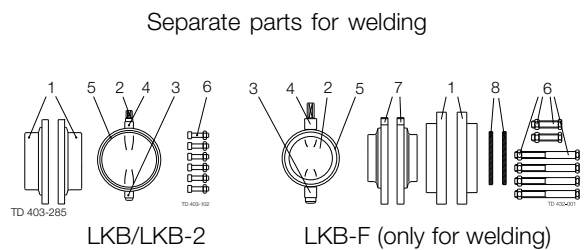

Step 3

Delivery of actuator and bracket:

1. Complete actuator with coupling and activating ring (ø85 mm) or indication pin (ø133 mm).
2. Bracket with screws for the actuator.
3. Mount the water rejector in the actuator

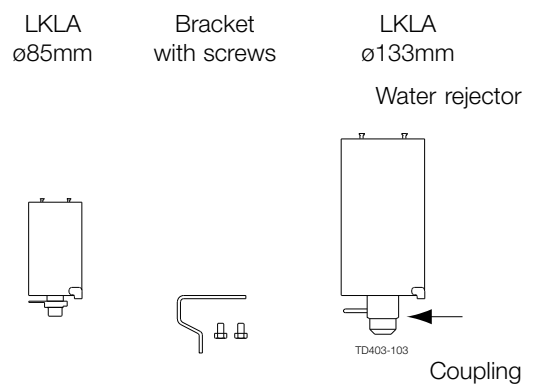

Step 4

1. Clean the valve/valve parts for possible packing materials.
2. Clean the handle or the actuator, if supplied.

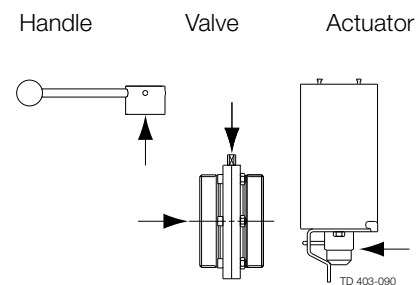

Remove packing materials!

Step 5

Inspection!

1. Inspect the valve/valve parts for visible transport damage.
2. Inspect the handle or the actuator, if supplied.

Caution!

Avoid damaging the valve/valve parts.

Avoid damaging the handle or the actuator, if supplied.

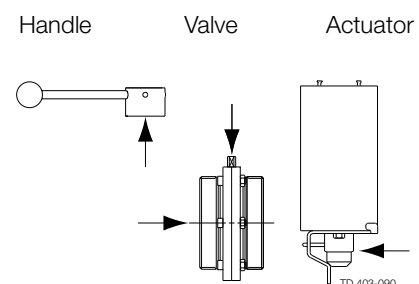

3 Installation

Read the instructions carefully. The valve has welding ends as standard but can also be supplied with fittings (not LKB-F).

NC = Normally closed.

NO = Normally open.

A/A = Air/air activated.

3.2 General installation

Step 1



Always read the technical data thoroughly.

See chapter 6 Technical data



Always release compressed air after use.

Never touch the coupling between the valve body and the actuator if compressed air is supplied to the actuator.

CAUTION

Alfa Laval cannot be held responsible for incorrect installation.

Step 2

Avoid stressing the valve.

Pay special attention to:

- Vibrations
- Thermal expansion of the tubes
- Excessive welding
- Overloading of the pipelines

Risk of damage!

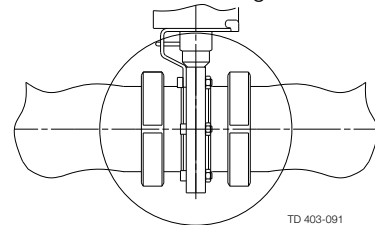

Step 3

Fittings:

Ensure that the connections are tight.

Remember seal rings!

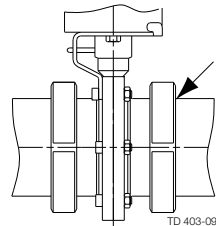

Step 4

Position of actuator:

Position the water rejector on the actuator correctly.

(The actuator can be installed in any position).

Turn the ventilation opening downwards!

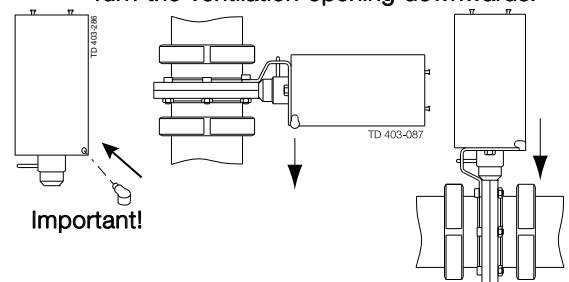

3 Installation

Read the instructions carefully. The valve has welding ends as standard but can also be supplied with fittings (not LKB-F).

NC = Normally closed.

NO = Normally open.

A/A = Air/air activated.

Air connection of actuator:

Connect compressed air correctly.

Pay special attention to the warnings!

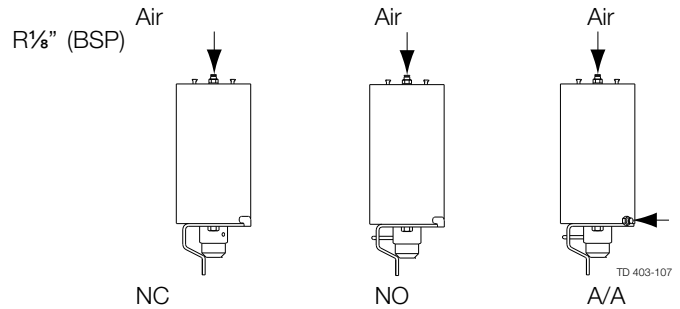

Pre-use check:

Open and close the valve several times to ensure that the valve disc moves smoothly against the seal ring.

Pay special attention to the warnings!

Note:

Removal of transportation bracket on A/A actuators, pos. 22 + 23 (Section 7.11)

3 Installation

Read the instructions carefully. The valve is supplied as separate parts to facilitate welding.

LKB: for ISO tubes.

LKB-2: for DIN tubes.

LKB-F: with flange connection.

3.3 Welding

Step 1

LKB/LKB-2

1. Weld the valve body halves into the pipelines.
2. Maintain the minimum clearance (A) so that the actuator can be removed.
3. If welding both valve body halves, ensure that they can be moved axially **B1 mm**, so that the valve parts can be removed.
4. After welding, assemble the valve according to steps 1-5, chapter 5.3 Assembly of valve - LKB/LKB-2/LKB-LP

LKB-F

1. Weld the flanges into the pipelines.
2. Maintain the minimum clearances (A and B2) so that the actuator and the valve parts can be removed.
3. After welding, assemble the valve according to steps 1-5, chapter 5.3 Assembly of valve - LKB/LKB-2/LKB-LP

Pre-use check - LKB/LKB-2/LKB-F

Open and close the valve several times to ensure that the valve disc moves smoothly against the seal ring.

Pay special attention to the warnings!



Caution!

Size	A (mm)				B ₁ (mm)	B ₂ (mm)
	Ø85		Ø133			
	LKLA	LKLA-T	LKLA	LKLA-T		
1"	245				20	43
1½"	245				20	43
2"	255				20	47
2½"	265				24	46
3"	265				24	59
4"	290		420		37	59
DN25	245	+ 172 (incl. top unit)		+ 172 (incl. top unit)	20	43
DN32	245				20	43
DN40	250				20	43
DN50	260				20	47
DN65	270				24	59
DN80	275		27	59		
DN100	290		420		27	59
DN125	315		440		30	63
DN250	325		445		41	79

3 Installation

Read the instructions carefully and pay special attention to the warnings!

NC = Normally closed.

NO = Normally open.

A/A = Air/air activated.

3.4 Fitting actuator/bracket/handle on the valve (optional extras)

Step 1

Bracket/indication:

1. Fit the bracket as shown.
2. Fit and tighten the screws.
3. Fit the activating ring/indication pin as shown.

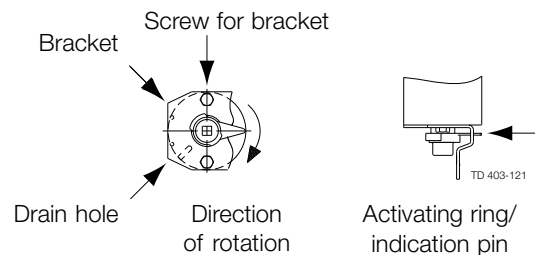

Step 2

Actuator/bracket - NC:

1. Ensure that the valve is closed by checking the position of the groove of the disc stem top.
2. Fit the actuator/bracket in accordance with chapter 5.3 Assembly of valve - LKB/LKB-2/LKB-LP, Step 4.

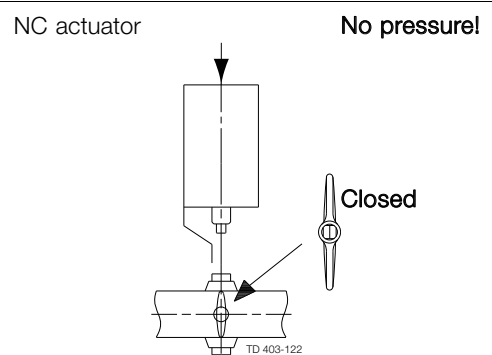

Step 3

Actuator/bracket - NO:

1. Ensure that the valve is open by checking the position of the groove of the disc stem top.
2. Fit the actuator/bracket in accordance with chapter 5.3 Assembly of valve - LKB/LKB-2/LKB-LP, Step 4.

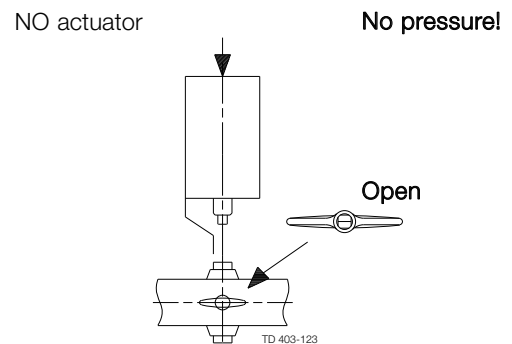

Step 4

Actuator/bracket - A/A:

1. Ensure that the valve is open by checking the position of the groove of the disc stem top.
2. Supply compressed air to the actuator.
3. Fit the actuator/bracket in accordance with chapter 5.3 Assembly of valve - LKB/LKB-2/LKB-LP, Step 4.

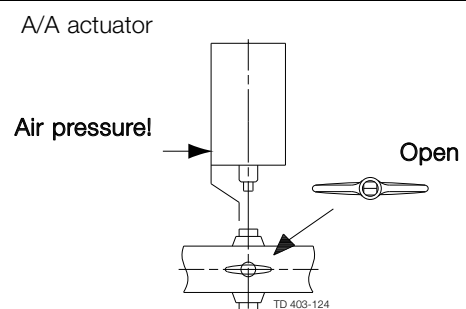

Step 5

Handle/indication:

1. Fit the standard handle on the valve so that the screw can enter the hole in the disc connection.
2. Fit the handle with position indication as shown and in accordance with chapter 5.3 Assembly of valve - LKB/LKB-2/LKB-LP, Step 3 + Step 4.

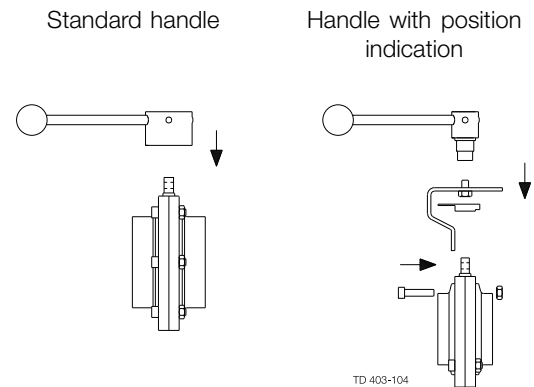

Pre-use check:

Open and close the valve several times to ensure that it operates smoothly.

Pay special attention to the warnings!

3.5 Recycling information

• Unpacking

- Packing material consists of wood, plastics, cardboard boxes and in some cases metal straps
- Wood and cardboard boxes can be reused, recycled or used for energy recovery
- Plastics should be recycled or burnt at a licensed waste incineration plant
- Metal straps should be sent for material recycling

• Maintenance

- During maintenance, oil and wear parts in the machine are replaced
- All metal parts should be sent for material recycling
- Worn out or defective electronic parts should be sent to a licensed handler for material recycling
- Oil and all non-metal wear parts must be disposed of in accordance with local regulations

• Scrapping

- At end of use, the equipment must be recycled according to the relevant local regulations. Beside the equipment itself, any hazardous residues from the process liquid must be considered and dealt with in a proper manner. When in doubt, or in the absence of local regulations, please contact your local Alfa Laval sales company

4 Operation

Read the instructions carefully and pay special attention to the warnings!
The valve is automatically or manually operated by means of an actuator or a handle.

4.1 Operation

Step 1



Always read the technical data thoroughly.
See chapter 6 Technical data

CAUTION

Alfa Laval cannot be held responsible for incorrect operation.

Step 2



Never touch the valve or the pipelines when processing hot liquids
or when sterilising.

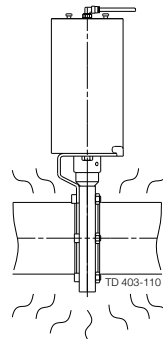

Danger of burns!

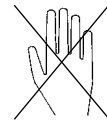

Step 3



Never touch the coupling between the valve body and the actuator
if compressed air is supplied to the actuator.

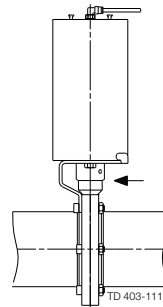

Air

Rotating parts

Step 4

Operation by means of actuator:

Automatic on/off operation by means of compressed air.

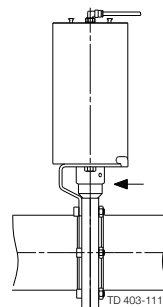

Air

Rotating parts

Step 5

Operation by means of standard handle:

1. Manual on/off operation.
2. Pull the handle outwards while rotating it.

NOTE!

This also applies for the Lockable Multiposition Handle.

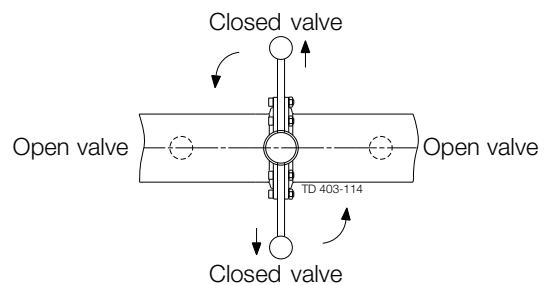

4 Operation

Pay attention to possible breakdown.

Read the instructions carefully.

LKB-F: With flange connection.

NC = Normally closed. NO = Normally open. A/A = Air/air activated.

Step 6

Operation by means of regulating handle:

1. Manual flow regulation because of infinite locking positions.
2. Loosen the handle, rotate it and tighten again.

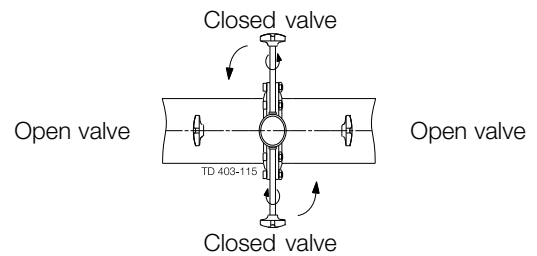

4.2 Troubleshooting

Step 1

NOTE!

Read the maintenance instructions carefully before replacing worn parts. - See chapter 5.1 General maintenance

Problem	Cause/result	Repair
<ul style="list-style-type: none"> - External leakage - Internal leakage by closed valve (normal wear) 	<ul style="list-style-type: none"> - Worn seal ring - Worn flange seal ring (LKB-F) 	Replace the seal ring and the bushes
<ul style="list-style-type: none"> - External leakage - Internal leakage by closed valve (too early) 	<ul style="list-style-type: none"> - High pressure - High temperature - Aggressive liquids - Many activations 	<ul style="list-style-type: none"> - Change rubber grade - Change the operating conditions
<ul style="list-style-type: none"> - Difficult to open/close - Damage to disc connection (high torque) 	Incorrect seal ring (swelling)	Replace by a seal ring of a different rubber grade
Difficult to open/close	<ul style="list-style-type: none"> - 90° displacement of the actuator - Incorrect actuator function (NC,NO) - Worn actuator bearings - Dirt penetration into the actuator 	<ul style="list-style-type: none"> - Fit correctly (see chapter 3.4 Fitting actuator/bracket/handle on the valve (optional extras)) - Change from NC to NO or vice versa - Replace the bearings - Service the actuator

4 Operation

The valve is designed for *Cleaning In Place (= CIP)*.
 Read the instructions carefully and pay special attention to the warnings!
 NaOH = Caustic Soda.
 HNO₃ = Nitric acid.

4.3 Recommended cleaning

Step 1



Always handle lye and acid with great care.

Caustic danger!



Always use
rubber gloves!



Always use
protective goggles!

Step 2



Never touch the valve or the pipelines when sterilising.

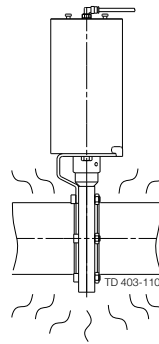

Danger of burns!

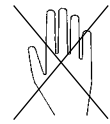

Step 3

Examples of cleaning agents:

Use clean water, free from chlorides.

1. 1% by weight NaOH at 70° C (158° F)

1 kg (2.2 lbs) NaOH	+	100 l (26.4 gal) water	=	Cleaning agent.
------------------------	---	---------------------------	---	-----------------

2. 0.5% by weight HNO₃ at 70° C (158° F)

0.7 l (0.2 gal) 53% HNO ₃	+	100 l (26.4 gal) water	=	Cleaning agent.
---	---	---------------------------	---	-----------------

2.2 l (0.6 gal) 33% NaOH	+	100 l (26.4 gal) water	=	Cleaning agent.
-----------------------------	---	---------------------------	---	-----------------

Step 4

- Avoid excessive concentration of the cleaning agent.
 ⇒ Dose gradually
- Adjust the cleaning flow to the process.
 ⇒ Sterilisation of milk/viscous liquids
 ⇒ Increase the cleaning flow
- Always** rinse well with clean water after the cleaning.

Always rinse!

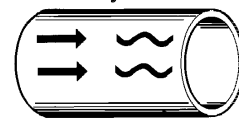

Clean water Cleaning agents

Step 5

NOTE

The cleaning agents must be stored/disposed of in accordance with current regulations/directives.

5 Maintenance

Maintain the valve and the regulator carefully. Read the instructions carefully and pay special attention to the warnings!
Always keep spare seal rings, rubber seals, bushes and actuator bearings in stock. Always use Alfa Laval genuine spare parts.
"Mushrooms" = fastening connections on the end cap.

5.1 General maintenance

Step 1



Always read the technical data thoroughly.
See section 6 Technical data



Always release compressed air after use.

NOTE

All scrap must be stored/disposed of in accordance with current regulations/directives.

Step 2



Never service the valve when it is hot.



Never service the valve with valve and pipelines under pressure.

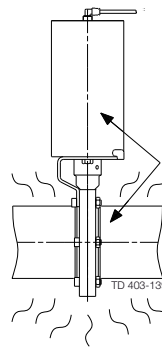

Atmospheric pressure required!

Danger of burns!

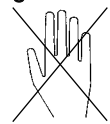

Step 3



Never stick your fingers through the valve ports if the actuator is supplied with compressed air.

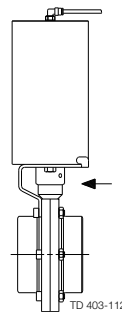

Air

Cutting danger!

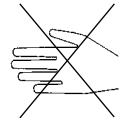

Step 4



Never touch the coupling between the valve body and the actuator if compressed air is supplied to the actuator.

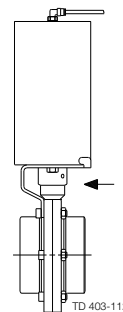

Air

Rotating parts

Step 5



Actuator size ø85 mm (NC/NO):
The actuator springs are **not** caged.

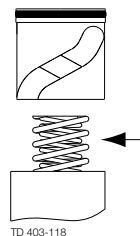

Springs
Caution!

5 Maintenance

Maintain the valve and the regulator carefully. Read the instructions carefully and pay special attention to the warnings! Always keep spare seal rings, rubber seals, bushes and actuator bearings in stock. Always use Alfa Laval genuine spare parts. "Mushrooms" = fastening connections on the end cap.

Step 6



End cap of actuator:

- **Never** remove the end cap by using compressed air.
- **Always** fit the end cap with the "mushrooms" turned outwards and position it correctly before supplying compressed air to the actuator.

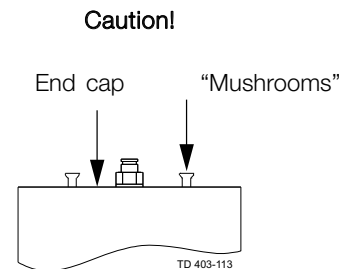

Recommended spare parts: Service kits (see chapter 7 Parts list and service kits).

Order service kits from the service kits list (see chapter 7 Parts list and service kits)

Ordering spare parts

Contact the Sales Department.

	Valve seal rings	Valve bushes	Actuator rubber seals	Actuator bearings
Preventive maintenance	Replace after 12 months	Replace when replacing the valve seal rings	Replace after 5 years	
Maintenance after leakage (leakage normally starts slowly)	Replace by the end of the day	Replace when replacing the valve seal rings	Replace when possible	
Planned maintenance	<ul style="list-style-type: none"> - Regular inspection for leakage and smooth operation - Keep a record of the valve - Use the statistics for inspection planning 	Replace when replacing the valve seal rings	<ul style="list-style-type: none"> - Regular inspection for leakage and smooth operation - Keep a record of the actuator - Use the statistics for planning of inspections 	Replace when they become worn
	Replace after leakage		Replace after air leakage	
Lubrication	Before fitting (use USDA-H1 approved) <ul style="list-style-type: none"> - Unisilcon L641(*) - Paraliq(*) GTE 703 - Molycote 111(D) 	None	Before fitting <ul style="list-style-type: none"> - Molycote Long term 2 Plus (Δ) - Molycote 1132(Δ) (for aggressive environment) 	When replacing actuator rubber seals <ul style="list-style-type: none"> - Molycote Long term 2 Plus (Δ) - Molycote 1132 (Δ) (for aggressive environment)

5 Maintenance

Read the instructions carefully. The items refer to the parts list and service kits section.

Handle scrap correctly.

LKB: for ISO tubes.

LKB-2: for DIN tubes.

5.2 Dismantling of valve - LKB/LKB-2/LKB-LP

Step 1

Valve with actuator:

1. Remove screws and nuts (6).
2. Remove the bracket with the actuator.

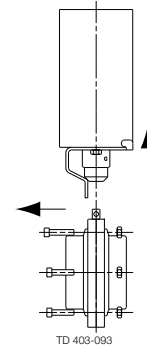

Step 2

Valve with handle:

1. Remove the complete handle.
2. Remove screws and nuts (6).

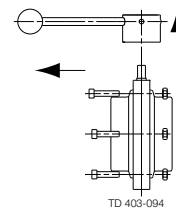

Step 3

Remove seal ring (5) together with valve disc (2).

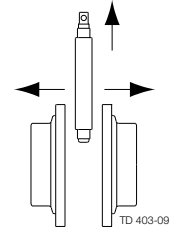

Step 4

Remove bushes (3, 4) from the disc stems.

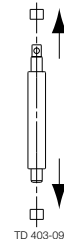

Step 5

Remove valve disc (2) from seal ring (5).

NOTE!

For valve sizes 25-38 mm and DN25-40, it is recommended to remove the valve disc by using a special service tool (item no. 9611981090).

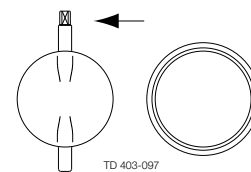

5 Maintenance

Read the instructions carefully. The items refer to the parts list and service kits section.

LKB: for ISO tubes. LKB-2: for DIN tubes.

Lubricate the seal ring before fitting it.

Lubricate the disc stem before fitting the bushes.

5.3 Assembly of valve - LKB/LKB-2/LKB-LP

Step 1

1. Lubricate the pin holes in seal ring (5), (important for Silicone and Viton).
2. Fit valve disc (2) in the seal ring (5).

NOTE!

For the valve sizes 25-38 mm and DN25-40, it is recommended to fit the valve disc by using a special service tool (item no. 9611981090).

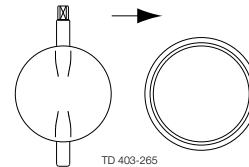

Step 2

1. Fit bushes (3,4) on the disc stem.
2. Fit seal ring (5) together with valve disc (2) between the two valve body halves (1).

CAUTION!

Rotate the valve disc so that the valve is open before tightening screws and nuts (6).

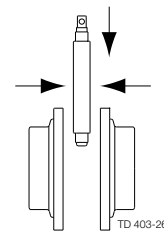

Step 3

Valve with handle:

1. Fit screws and nuts (6) and torque tighten in accordance with the requirements (see Step 5).
2. Fit the complete handle on the disc connection and tighten the screw on the handle.

NOTE!

This also applies for the Lockable Multiposition Handle.

To avoid seizing the bolts have to be lubricated with Molykote TP-42 Paste or similar Anti-seize lubricant.

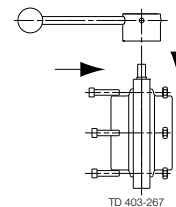

Step 4

Valve with actuator:

1. Fit the actuator with the bracket so that the disc connection enters the coupling (see Chapter 3.4 Fitting actuator/bracket/handle on the valve (optional extras)).
2. Fit screws and nuts (6) and torque tighten in accordance with the requirements so that the bracket is fixed to the valve (see Step 5).

Fit correctly!

See chapter 3.4 Fitting actuator/bracket/handle on the valve (optional extras)

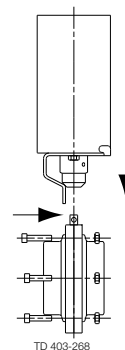

5 Maintenance

Read the instructions carefully. The items refer to the parts list and service kits section.

LKB: for ISO tubes. LKB-2: for DIN tubes.

Lubricate the seal ring before fitting it.

Lubricate the disc stem before fitting the bushes.

Step 5

Pre-use check:

Check that the valve disc moves smoothly against the seal ring.

Pay special attention to the warnings!

Tools/torque values for assembly of the valve body halves:

Valve size	25 mm DN 25	DN32	38 mm DN40	51 mm DN50	63.5 mm DN65	76 mm DN80	101.6 mm DN100	DN 125	DN150
Allen Key	5 mm (0.2")	5 mm (0.2")	5 mm (0.2")	6 mm (0.24")	6 mm (0.24")	6 mm (0.24")	8 mm (0.3")	8 mm (0.3")	8 mm (0.3")
Recomm. Torque	18 Nm (13 lbf-ft)	18 Nm (13 lbf-ft)	18 Nm (13 lbf-ft)	20 Nm (15 lbf-ft)	20 Nm (15 lbf-ft)	20 Nm (15 lbf-ft)	38 Nm (28 lbf-ft)	38 Nm (28 lbf-ft)	38 Nm (28 lbf-ft)

5 Maintenance

Read the instructions carefully.

The items refer to the parts list and service kits section.

Handle scrap correctly.

LKB-F: with flange connection.

5.4 Dismantling of valve - LKB-F

Step 1

1. Loosen the two upper screws and nuts (6).
2. Loosen and remove the two lower screws and nuts (6).
3. Remove the valve unit from flanges (7).

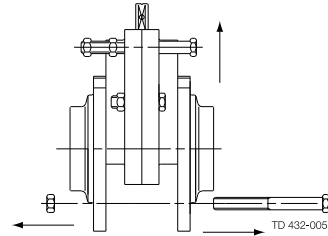

Step 2

1. Remove the two upper screws and nuts (6), (4 nuts).
2. If supplied, remove the actuator from the valve body unit.
3. If supplied, loosen the screw and remove the handle from the valve body unit.

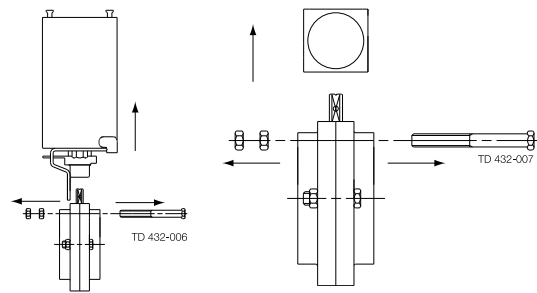

Step 3

1. Loosen and remove the two centre screws and nuts (6).
2. Remove seal ring (5) together with valve disc (2).
3. Remove flange seal rings (8).

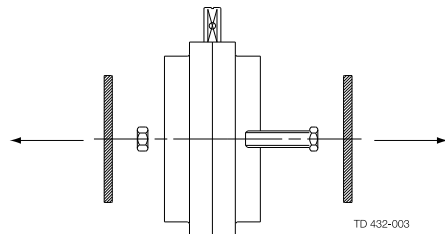

Step 4

Remove bushes (3,4) from the disc stems.

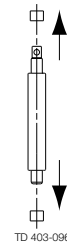

Step 5

Remove valve disc (2) from seal ring (5).

NOTE!

For valve sizes 25-38 mm and DN25-40, it is recommended to remove the valve disc by using a special service tool (item no. 9611981090).

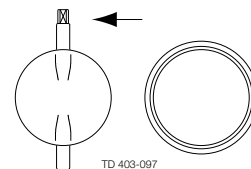

5 Maintenance

Read the instructions carefully. The items refer to the parts list and service kits section.

LKB-F: With flange connection.

Lubricate the seal rings before fitting them.

Lubricate the disc stem before fitting the bushes.

5.5 Assembly of valve - LKB-F

Step 1

1. Lubricate the pin holes in seal ring (5), (important for Silicone and Viton).
2. Fit valve disc (2) on seal ring (5).
3. Fit bushes (3,4) in the disc stem.

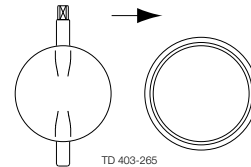

NOTE!

For valve size 25-38 mm and DN25-40, it is recommended to fit the valve disc by using a special service tool (item no. 9611981090).

Step 2

1. Lubricate flange seal rings (8) with water and fit them.
2. Fit seal ring (5) together with valve disc (2) between the valve body halves (1).
3. Fit and tighten the two centre screws and nuts (6).

CAUTION!

Rotate the valve disc so that the valve is open before tightening screws and nuts (6).

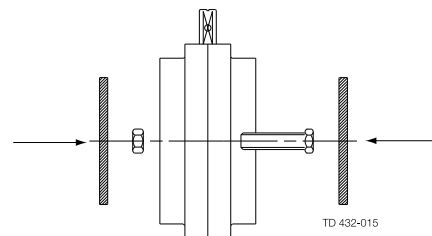

Step 3

1. If supplied, fit the handle and tighten the screw.
2. If supplied, fit the actuator.
3. Fit the two upper screws and nuts (6), (4 nuts).

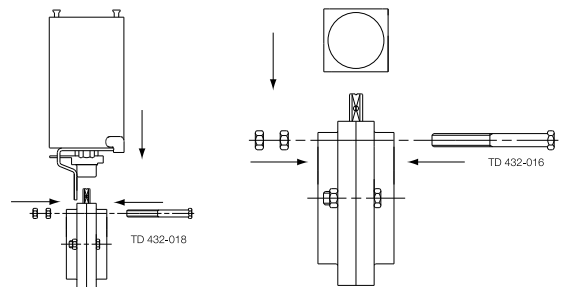

Step 4

1. Fit the valve unit between flanges (7).
2. Fit and tighten the two lower screws and nuts (6).
3. Tighten the two upper screws and nuts (6).

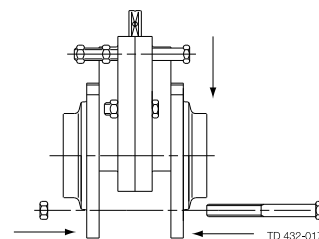

Step 5

Pre-use check: Check that the valve disc moves smoothly against the seal ring.

Pay special attention to the warnings!

Tools/torque values for assembly of the valve body halves:

Valve size	25 mm DN 25	DN32	38 mm DN40	51 mm DN50	63.5 mm DN65	76 mm DN80	101.6 mm DN100	DN 125	DN150
Spanner flats	10 mm (0.4")	10 mm (0.4")	10 mm (0.4")	13 mm (0.5")	13 mm (0.5")	13 mm (0.5")	17 mm (0.67")	17 mm (0.67")	17 mm (0.67")
Recomm. torque	18 Nm (13 lbf-ft)	18 Nm (13 lbf-ft)	18 Nm (13 lbf-ft)	20 Nm (15 lbf-ft)	20 Nm (15 lbf-ft)	20 Nm (15 lbf-ft)	38 Nm (28 lbf-ft)	38 Nm (28 lbf-ft)	38 Nm (28 lbf-ft)

5 Maintenance

Read the instructions carefully. The items refer to the parts list and service kits section.

Handle scrap correctly.

NC = Normally closed. NO = Normally open. A/A = Air/air activated.

5.6 Dismantling of actuator

Step 1

1. Press end cap (5) into air cylinder (1).
2. Remove retaining ring (6).

Use a press or special tool (item no. 9611416791).

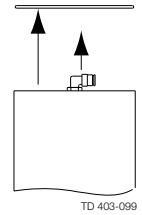

Step 2

NC/NO actuator:

Release the pressure on end cap (5) carefully and remove the end cap.

Pay special attention to the warning!

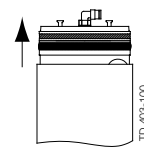

Step 3

A/A actuator:

Remove end cap (5) by hand.

Pay special attention to the warning!

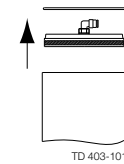

Step 4

Remove piston (3) and the springs.

NOTE!

- The actuator size $\varnothing 133$ mm has a caged spring assembly.
- The air/air actuator has no springs.

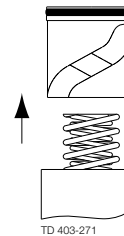

Step 5

Remove connex pin (16) and coupling (17) from rotating cylinder stem (2).

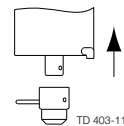

Step 6

Remove rotating cylinder (2) and the remaining internal parts from air cylinder (1).

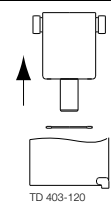

5 Maintenance

Read the instructions carefully.

NC = Normally closed. NO = Normally open. A/A = Air/air activated.

Lubricate the rubber seals before fitting them. Lubricate the bearings.

Clean the piston before assembly.

5.7 Assembly of actuator

Step 1

Fit rotating cylinder (2) in air cylinder (1).

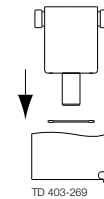

Step 2

Fit coupling (17) on rotating cylinder stem (2) and fit connex pin (16).

Fit the connex pin correctly!

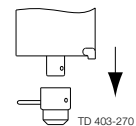

Step 3

Fit the springs in rotating cylinder (2) and fit piston (3) carefully.

CAUTION!

Fit the piston correctly in relation to the bearings.

NOTE!

The air/air actuator has no springs.

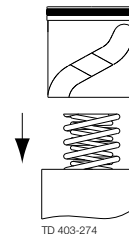

Fit correctly!

Step 4

A/A actuator:

1. Fit end cap (5) sufficiently into air cylinder (1) so that retaining ring (6) can be fitted in the air cylinder.
2. Position the end cap correctly by hand.

Pay special attention to the warning!

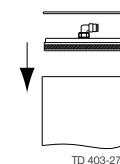

Step 5

1. Fit end cap (5) in air cylinder (1) and press down sufficiently so that retaining ring (6) can be fitted in the air cylinder.
2. Release the pressure on the end cap.

Pay special attention to the warning!

Use a press or special tool (item no. 9611416791).

Use a press!

NC/NO actuator

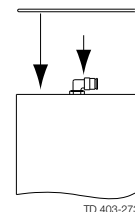

Step 6

Pre-use check:

1. Supply compressed air to the actuator.
2. Activate the actuator several times to ensure that it operates smoothly.

Pay special attention to the warnings!

6 Technical data

It is important to observe the technical data during installation, operation and maintenance.

Inform personnel about the technical data.

NC = Normally closed. NO = Normally open. A/A = Air/air activated.

6.1 Technical data

LKB is a sanitary automatically or manually operated butterfly valve for use in stainless steel pipe systems.

LKB is either remote-controlled by means of an actuator or manually operated by means of a handle.

The actuator is made in three standard versions, normally closed (NC), normally open (NO) and air/air activated (A/A).

The actuator is designed so that an axial movement of a piston is transformed into a 90° rotation of a shaft. The torque of the actuator is increased when the valve disc contacts the seal ring of the butterfly valve.

The handle for manual operation mechanically locks the valve in its open or closed position. The handles for the valve sizes DN125 and DN150, which are designed for locking in two intermediate positions, enable adjusting of the valve, so that the flow rate can be regulated.

Valve - data	
Max. product pressure	1000 kPa (10 bar) (145 psi)
Min. product pressure	Full vacuum
Temperature range	-10° C to +140° C* (EPDM) However max. 95° C when operating the valve
Product acc. to PED 97/23/EC	Fluids group 2
Valve - materials	
Product wetted steel parts	AISI 304 or AISI 316L
Other steel parts	AISI 304
Rubber grades	EPDM, Silicone (Q), Viton (FPM), HNBR, PFA
Bushes for valve disc	PVDF
Finish	Semi-bright
Inside surface finish	≤Ra 0.8 µm
Actuator - data	
Max. air pressure	600 kPa (6 bar) (87 psi)
Min. air pressure, NC or NO	400 kPa (4 bar) (58 psi)
Temperature range	-25° C to +90° C (-13°F to +194°F)
Air consumption (litres free air)	- ø85 mm 0.24 x p (bar) - ø133 mm 0.95 x p (bar)
Actuator - materials	
Actuator body	AISI 304
Piston	Light alloy, bronze for ø85 mm A/A
Seals	Nitrile (NBR)
Housing for switches	Noryl (PPO)
Finish	Semi bright

6 Technical data

It is important to observe the technical data during installation, operation and maintenance.

Inform personnel about the technical data.

NC = Normally closed. NO = Normally open. A/A = Air/air activated.

Weight (kg)

Size	25 mm	38 mm	51 mm	63.5 mm	76.1 mm	101.6 mm	DN 25	DN 32	DN 40	DN 50	DN 65	DN 80	DN 100	DN 125	DN 150
Weight LKB-F with welding ends and handle	1.6	1.3	2.1	2.9	5.0	7.9	1.6	1.6	1.7	2.6	4.7	5.8	7.9	11.7	12.3
Weight LKB/LKB-2 with welding ends and handle	1.2	1.0	1.5	2.1	3.0	4.7	1.2	1.1	1.3	1.8	3.0	3.5	5.1	7.5	9.0
Weight LKB-F with welding ends and LKLA/LKLA-T ø85	4.3	4.0	4.8	5.6	7.6	19.5	4.3	4.3	4.4	5.3	7.3	8.4	19.5	23.3	23.9
Weight LKB/LKB-2 with welding ends and LKLA/LKLA-T ø133	3.9	3.7	4.2	4.8	5.6	16.3	3.8	3.8	4.0	4.5	5.6	6.1	16.7	19.1	20.6

Noise

One metre away from - and 1.6 metre above the exhaust, the noise level of a valve actuator will be approximately 77dB(A) without noise damper and approximately 72 dB(A) with noise damper - Measured at 7 bars air pressure.

7 Parts list and service kits

The drawings include all parts of the valves. For the parts list, please see chapters 7.5 LKB Butterfly valve, ISO, 7.6 LKB-F Butterfly valves, ISO, 7.7 LKB-F Butterfly valves, DIN, 7.8 LKB-2 Butterfly valves
Always use Alfa Laval genuine spare parts. The warranty of Alfa Laval products is dependent on the use of Alfa Laval genuine spare parts.

7.1 LKB, LKB-2, LKB-F Butterfly valves, drawings

LKB/LKB-2

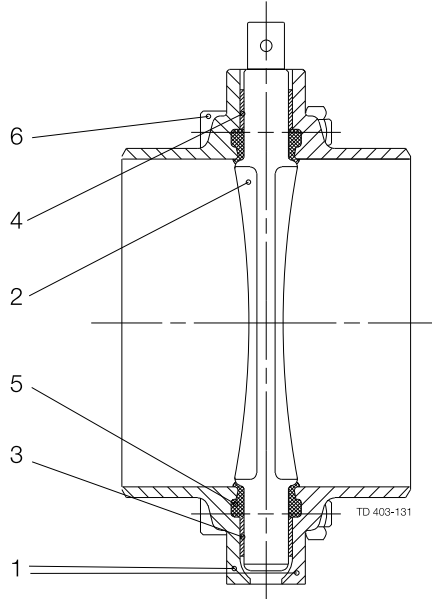

LKB-F

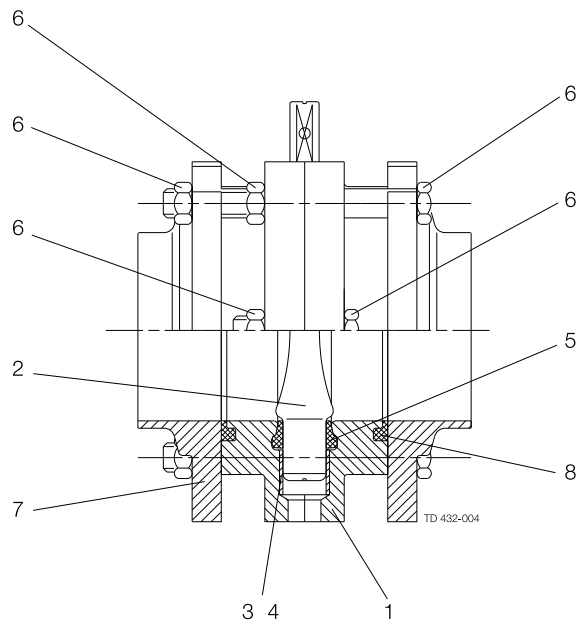

7 Parts list and service kits

The drawings include all parts of the actuators.
For the parts list, please see chapter 7.9 LKB-LP Butterfly valve

7.2 LKB-LP Butterfly valve, drawing

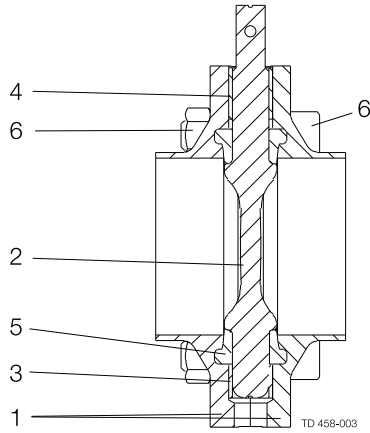

7 Parts list and service kits

The drawings include all parts of the actuators.

For the parts list, please see chapters 7.10 LKLA $\varnothing 85$ mm (NO/NC) - 7.19 LKLA-T $\varnothing 133$ mm (A/A).

7.3 LKLA and LKLA-T actuators $\varnothing 85$ mm, drawings

LKLA-T (NC-NO)

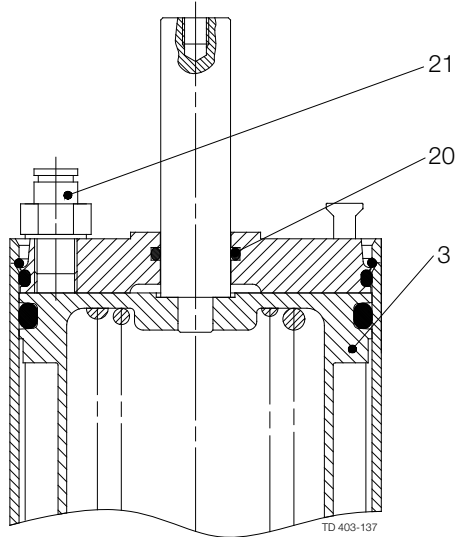

LKLA-T (A/A)

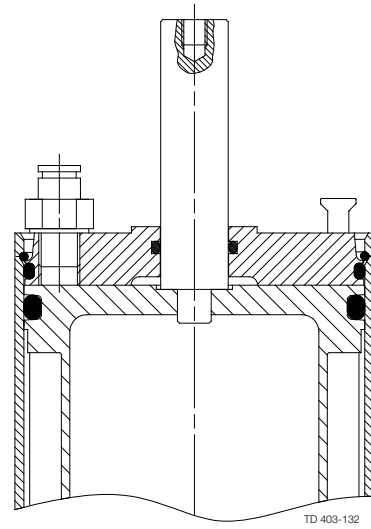

LKLA (NC-NO)

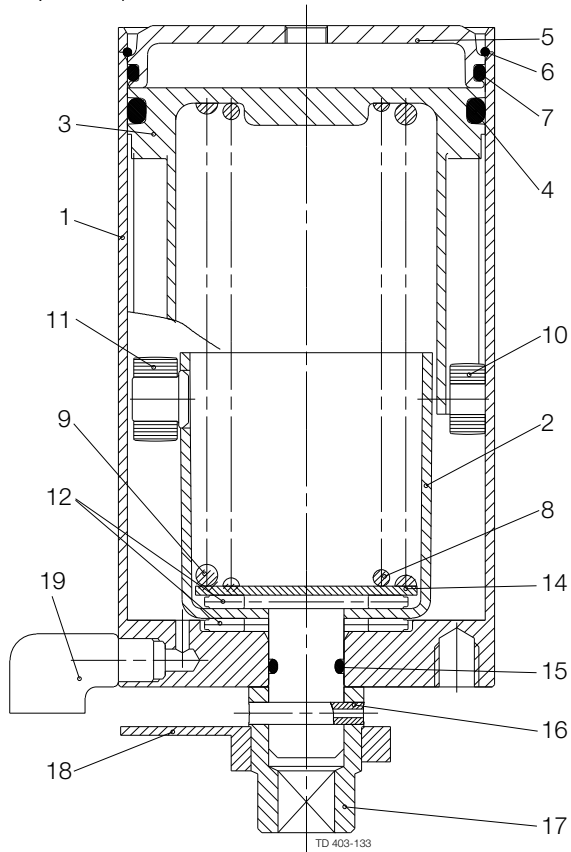

LKLA (A/A)

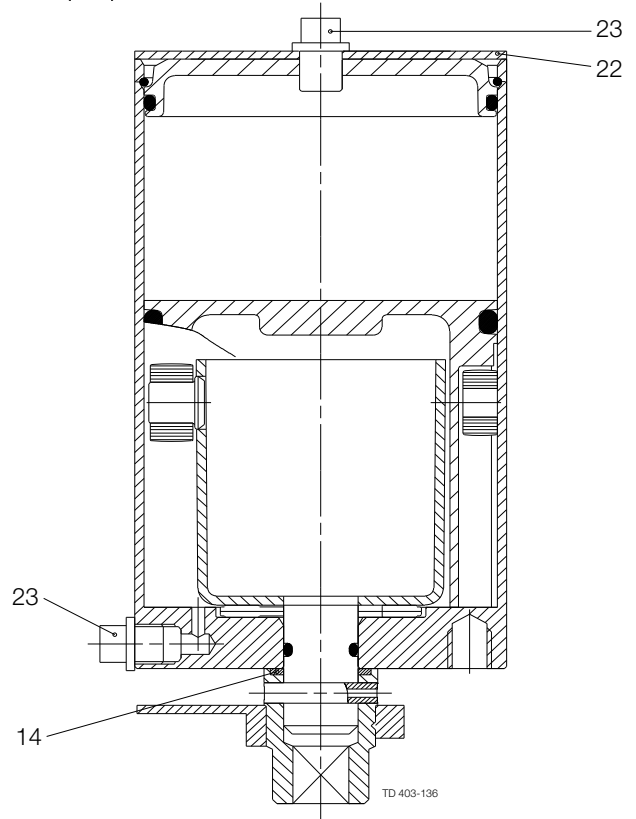

7 Parts list and service kits

The drawings include all parts of the actuators.

For the parts list, please see chapters 7.10 LKLA $\varnothing 85$ mm (NO/NC) - 7.19 LKLA-T $\varnothing 133$ mm (A/A).

DN 125-150 (A/A)

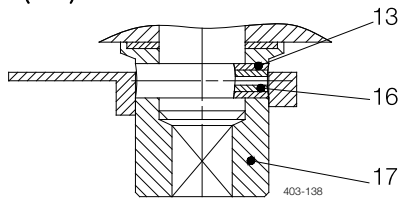



7 Parts list and service kits

The drawings include all parts of the actuators.

For the parts list, please see chapters 7.10 LKLA $\varnothing 85$ mm (NO/NC) - 7.19 LKLA-T $\varnothing 133$ mm (A/A).

7.4 LKLA and LKLA-T actuators $\varnothing 133$ mm, drawings

LKLA-T (NC-NO)

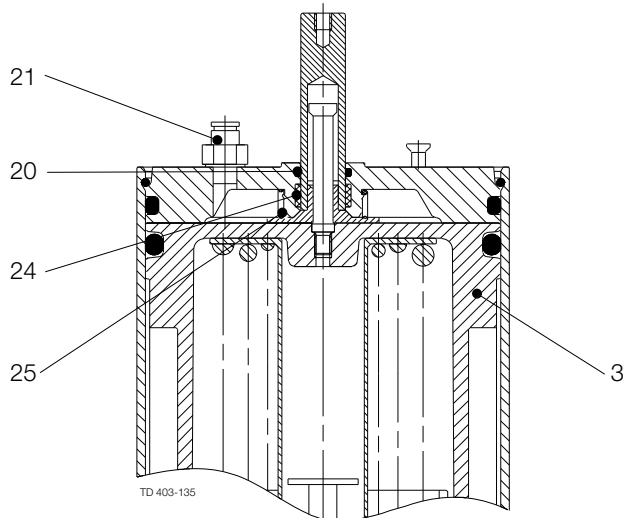

LKLA-T (A/A)

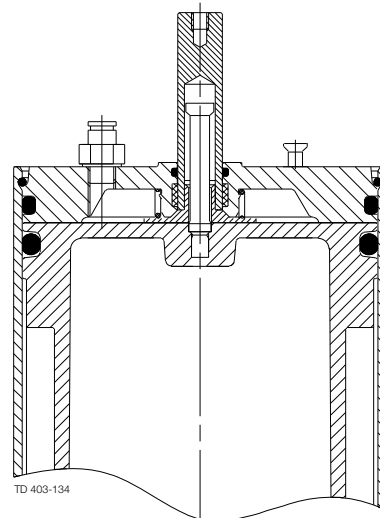

LKLA (NC-NO)

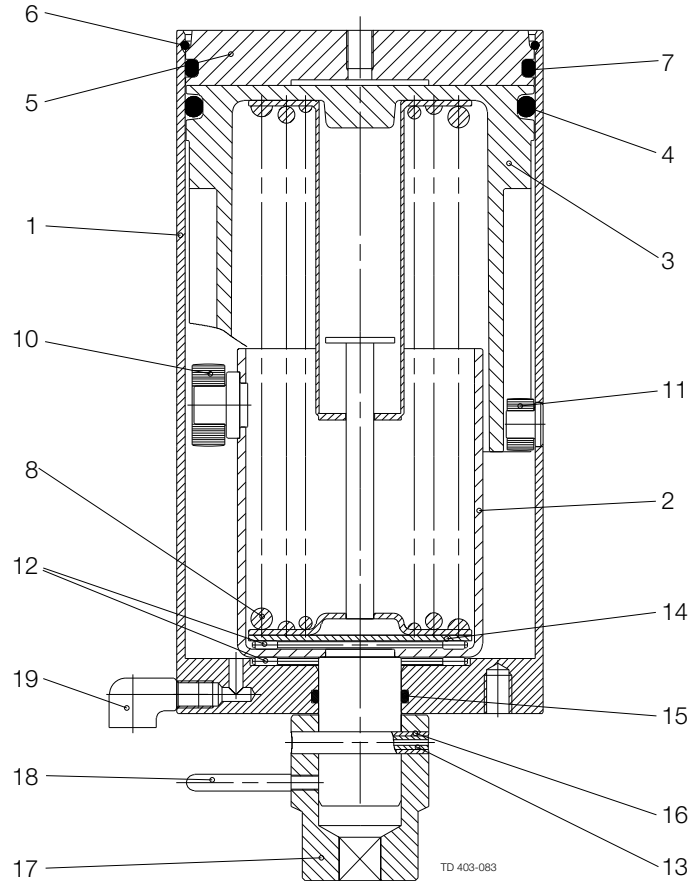

LKLA (A/A)

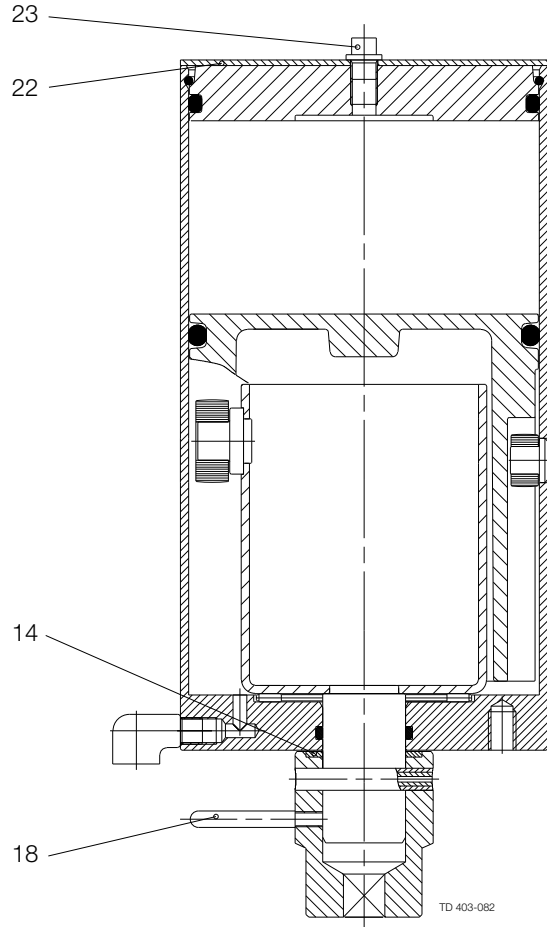

7 Parts list and service kits

The drawing and parts list include all items of the valve.

7.5 LKB Butterfly valve, ISO

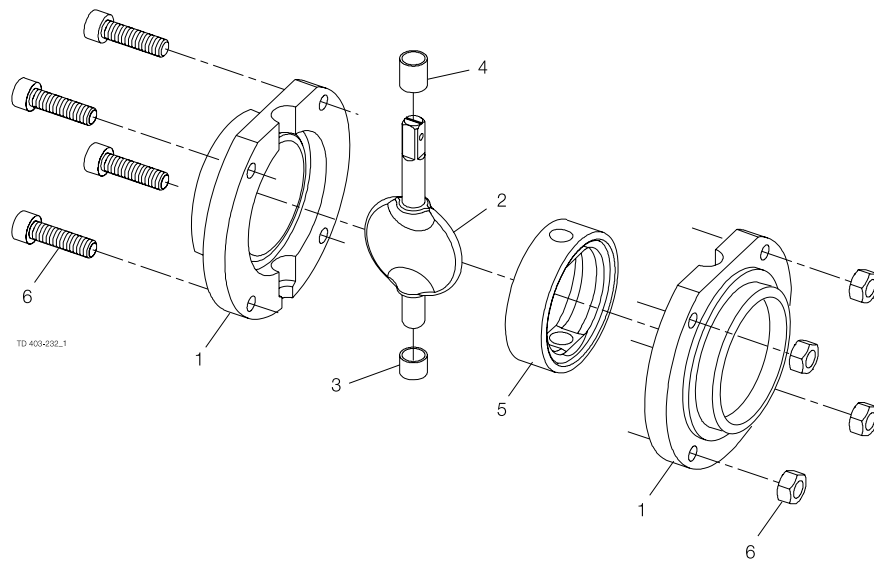

7 Parts list and service kits

The drawing and parts list include all items of the valve.

Parts list

Pos.	Qty	Denomination
1	2	Valve body half
2	1	Disc
3 □	1	Bush
	1	Bush, set (10 pcs.)
4 □	1	Bush
	1	Bush, set (10 pcs.)
5 □	1	Seal ring
6	1	Set of screws

Service kits

Denomination	25 mm Disc □ 8	38 mm Disc □ 8	51 mm Disc □ 8	63.5 mm Disc □ 8
Service kits for product wetted parts				
□ Service kit EPDM	9611923028	9611923029	9611923030	9611923031
□ Service kit Q	9611923034	9611923035	9611923036	9611923037
□ Service kit FPM	9611923040	9611923041	9611923042	9611923043
□ Service kit HNBR	9611923160	9611923161	9611923162	9611923163
□ Service kit PFA		9611923183	9611923184	9611923185

Service kits

Denomination	76mm Disc □ 10	101.6mm Disc □ 10	101.6mm Disc □ 12	152mm Disc □ 15
Service kits for product wetted parts				
□ Service kit EPDM	9611923032	9611923033	9611923033	9611923046
□ Service kit Q	9611923038	9611923039	9611923039	9611923047
□ Service kit FPM	9611923044	9611923045	9611923045	9611923048
□ Service kit HNBR	9611923164	9611923165	9611923165	9611923197
□ Service kit PFA	9611923186	9611923187	9611923187	

NB: * Disc connection □ 10 for 101.6 mm and DN100 is no longer available. Please rebuild the air actuator or/and handle to: disc connection □ 12 Reg. 2.14.1 9805 / Intro. 8001

NOTE! Lubricate the pin holes in the seal (5) with Klüber Paraliq GTE 703 or similar. Very important for Q and FPM.

Parts marked with □ are included in the service kits. Recommended spare parts: Service kits.

900069/4

7 Parts list and service kits

The drawing and parts list include all items of the valve.

7.6 LKB-F Butterfly valves, ISO

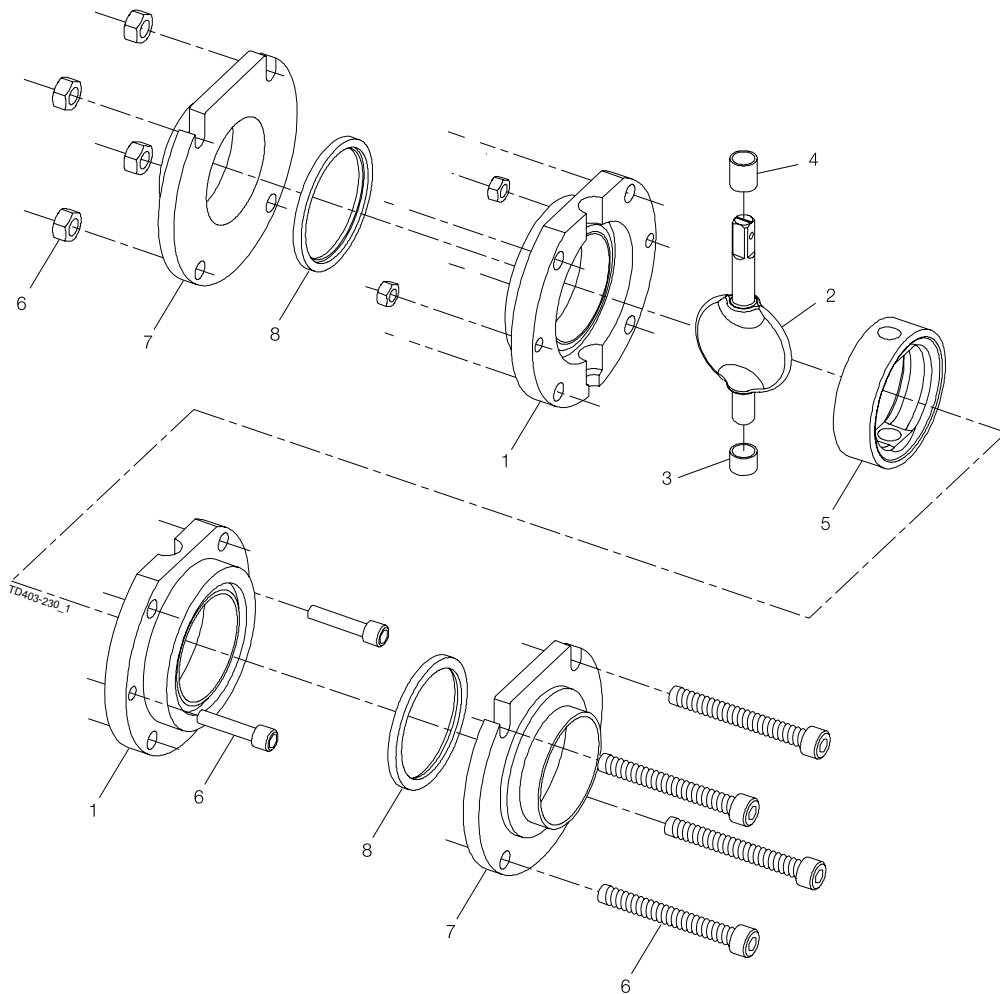

7 Parts list and service kits

The drawing and parts list include all items of the valve.

Parts list

Pos.	Qty	Denomination
1	2	Valve body half
2	1	Disc
3 □	1	Bush
	1	Bush set (10 pcs.)
4 □	1	Bush
	1	Bush set (10 pcs.)
5 □	1	Seal ring
6	1	Set of screws and nuts
7	2	Flange
8 □	2	Seal ring

Service kits

Denomination	25 mm Disc □ 8	38 mm Disc □ 8	51 mm Disc □ 8	63.5 mm Disc □ 8	76 mm Disc □ 10	101.6 mm Disc □ 12
Service kits for product wetted parts						
□ Service kit, EPDM	9611923058	9611923059	9611923060	9611923061	9611923062	9611923063
□ Service kit, Silicone (Q)	9611923064	9611923065	9611923066	9611923067	9611923068	9611923069
□ Service kit, FPM	9611923070	9611923071	9611923072	9611923073	9611923074	9611923099
□ Service kit, HNBR	9611923310	9611923311	9611923312	9611923313	9611923314	9611923315
□ Service kit, PFA**						

Parts marked with □ are included in the service kits.
Recommended spare parts: Service kits.

NB:

* Disc connection □ 10 for 101.6 mm and DN 100 is no longer available. Please rebuild the air-actuator or/and handle to: disc connection □ 12

** Service kits for PFA are delivered with EPDM flange seals.

900529/4

7 Parts list and service kits

The drawing and parts list include all items.

7.7 LKB-F Butterfly valves, DIN

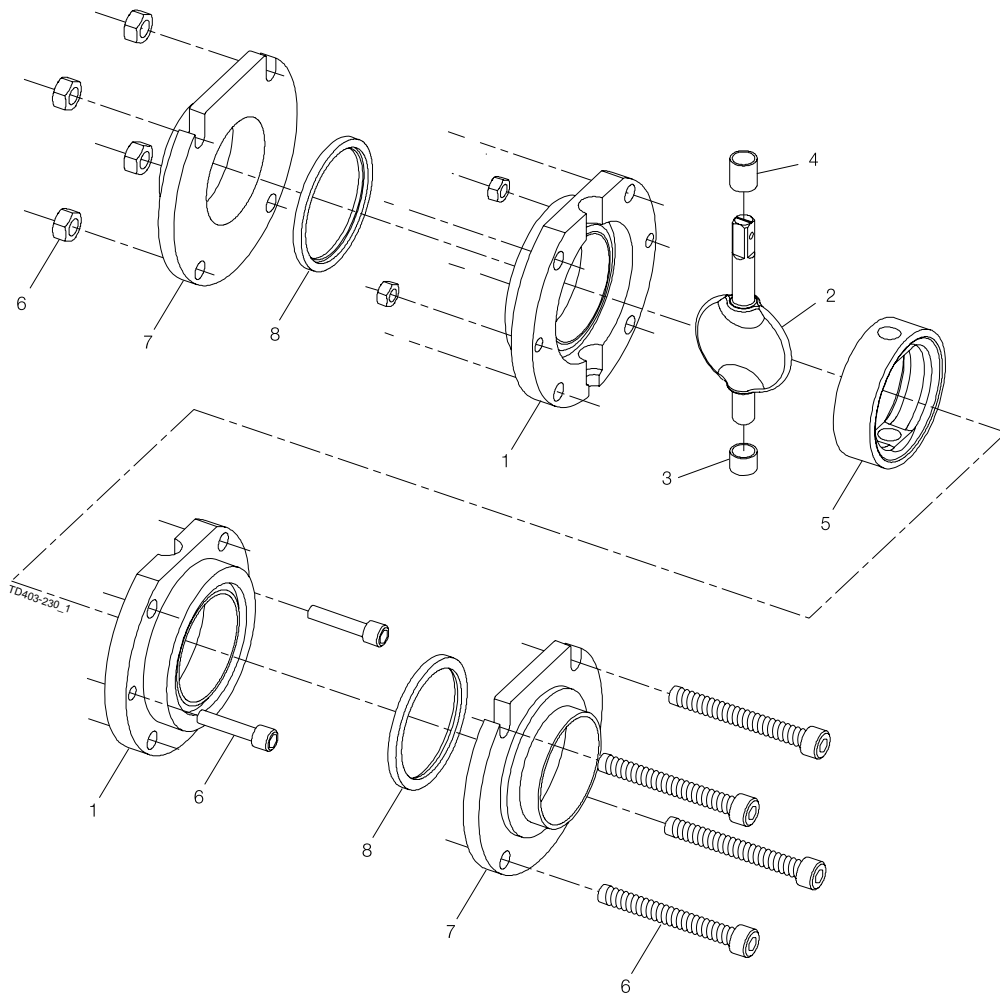

7 Parts list and service kits

The drawing and parts list include all items.

Parts list

Pos.	Qty	Denomination
1	2	Valve body half
2	1	Disc
3	1	Bush
	1	Bush set (10 pcs.)
	1	Bush set (10 pcs.)
	1	Bush set (10 pcs.)
4	1	Bush
	1	Bush set (10 pcs.)
5	1	Seal ring
	1	Seal ring
	1	Seal ring
6	1	Set of screws and nuts
7	2	Flange
8	2	Seal ring

Service kits

Denomination	DN 25 Disc □ 8	DN 32 Disc □ 8	DN 40 Disc □ 8	DN 50 Disc □ 8
Service kits for product wetted parts				
□ Service kit, EPDM	9611923100	9611923101	9611923102	9611923103
□ Service kit, Silicone (Q)	9611923109	9611923110	9611923111	9611923112
□ Service kit, FPM	9611923118	9611923119	9611923120	9611923121
Service kit, HNBR				
Service kit, PFA				

Service kits

Denomination	DN 65 Disc □ 10	DN 80 Disc □ 10	DN 100 Disc □ 12	DN 125 Disc □ 14	DN 150 Disc □ 15
□ Service kit, EPDM	9611923104	9611923105	9611923106	9611923107	9611923108
□ Service kit, Silicone (Q)	9611923113	9611923114	9611923115	9611923116	9611923117
□ Service kit, FPM	9611923122	9611923123	9611923124	9611923125	9611923126
Service kit, HNBR					
Service kit, PFA					

Parts marked with □ are included in the service kits.

Recommended spare parts: Service kits.

1) Seal ring is delivered assembled with disc.

NB: * Service kits for HNBR and PFA are delivered with EPDM flange seals.

900529/4

7 Parts list and service kits

The drawing and parts list include all items.

7.8 LKB-2 Butterfly valves

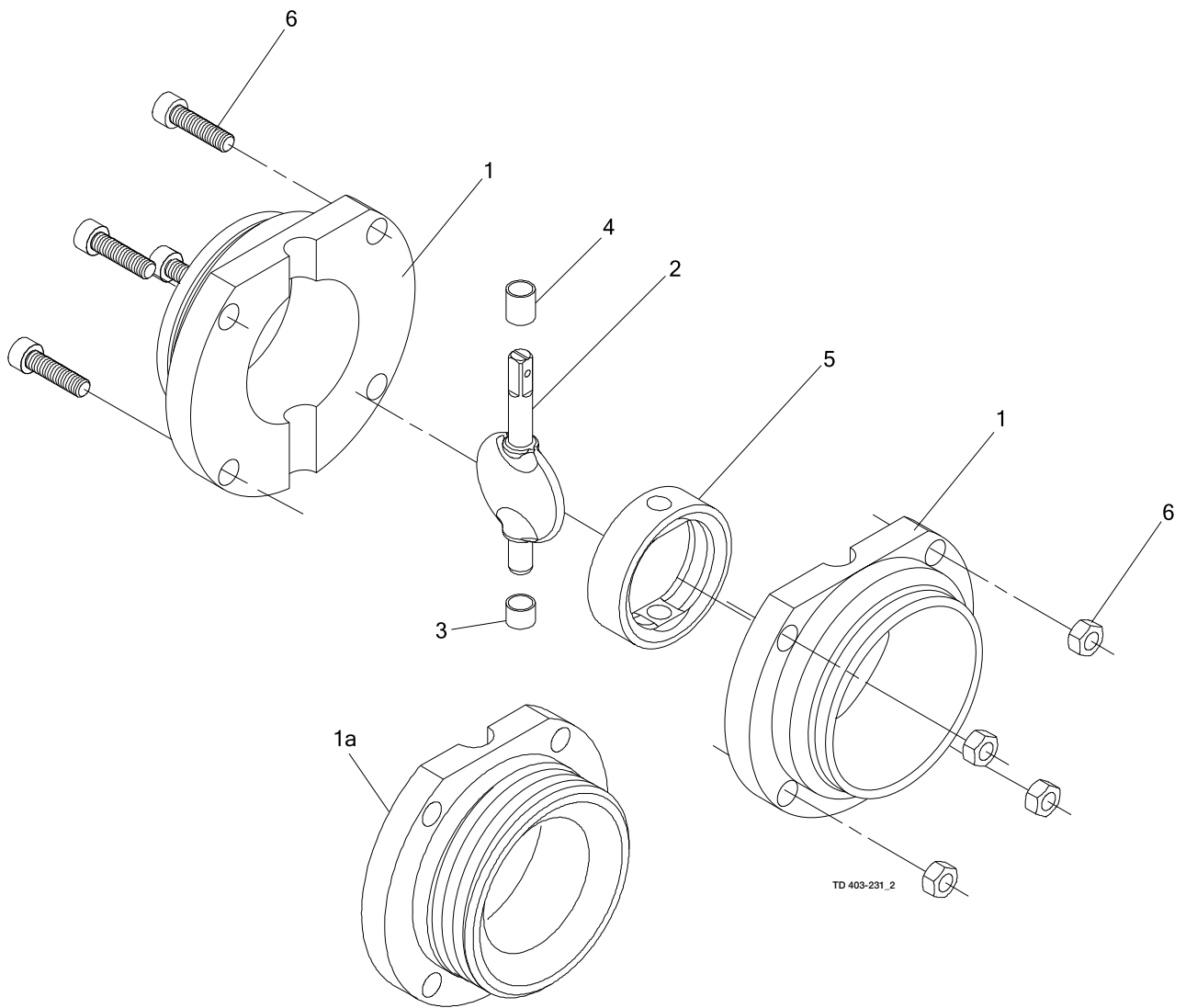

7 Parts list and service kits

The drawing and parts list include all items.

Parts list

Pos.	Qty	Denomination
1a	2	Valve body half
1	2	Valve body half
2	1	Disc
3	1	Bush
	1	Bush, set (10 pcs.)
4	1	Bush
	1	Bush, set (10 pcs.)
	1	Bush, set (10 pcs.)
5	1	Seal ring
6	1	Set screw

Service kits

Denomination	DN25 Disc □ 8	DN32 Disc □ 8	DN40 Disc □ 8	DN50 Disc □ 8
Service kits for product wetted parts				
□ Service kit, EPDM	9611923075	9611923076	9611923077	9611923078
□ Service kit, Q	9611923083	9611923084	9611923085	9611923086
□ Service kit, FPM	9611923091	9611923092	9611923093	9611923094
□ Service kit, HNBR	9611923210	9611923211	9611923212	9611923213
□ Service kit, PFA			9611923191 ¹⁾	9611923192

Service kits

Denomination	DN65 Disc □ 10	DN80 Disc □ 10	DN100 Disc □ 12	DN125 Disc □ 14	DN 150
Service kits for product wetted parts					
□ Service kit, EPDM	9611923079	9611923080	9611923081	9611923082	9611923046
□ Service kit, Q	9611923087	9611923088	9611923089	9611923090	9611923047
□ Service kit, FPM	9611923095	9611923096	9611923097	9611923098	9611923048
□ Service kit, HNBR	9611923214	9611923215	9611923216	9611923217	9611923197
□ Service kit, PFA	9611923193	9611923194	9611923195		

NB:¹⁾ In the service kit the seal ring is delivered assembled with disc.

NOTE!! Lubricate the pin holes in the seal (5) with Klüber Paraliq GTE 703 or similar. Very important for Q and FPM.

Parts marked with □ are included in the service kits. Recommended spare parts: Service kits.

900245/4



7 Parts list and service kits

The drawing and parts list include all items.

7.9 LKB-LP Butterfly valve

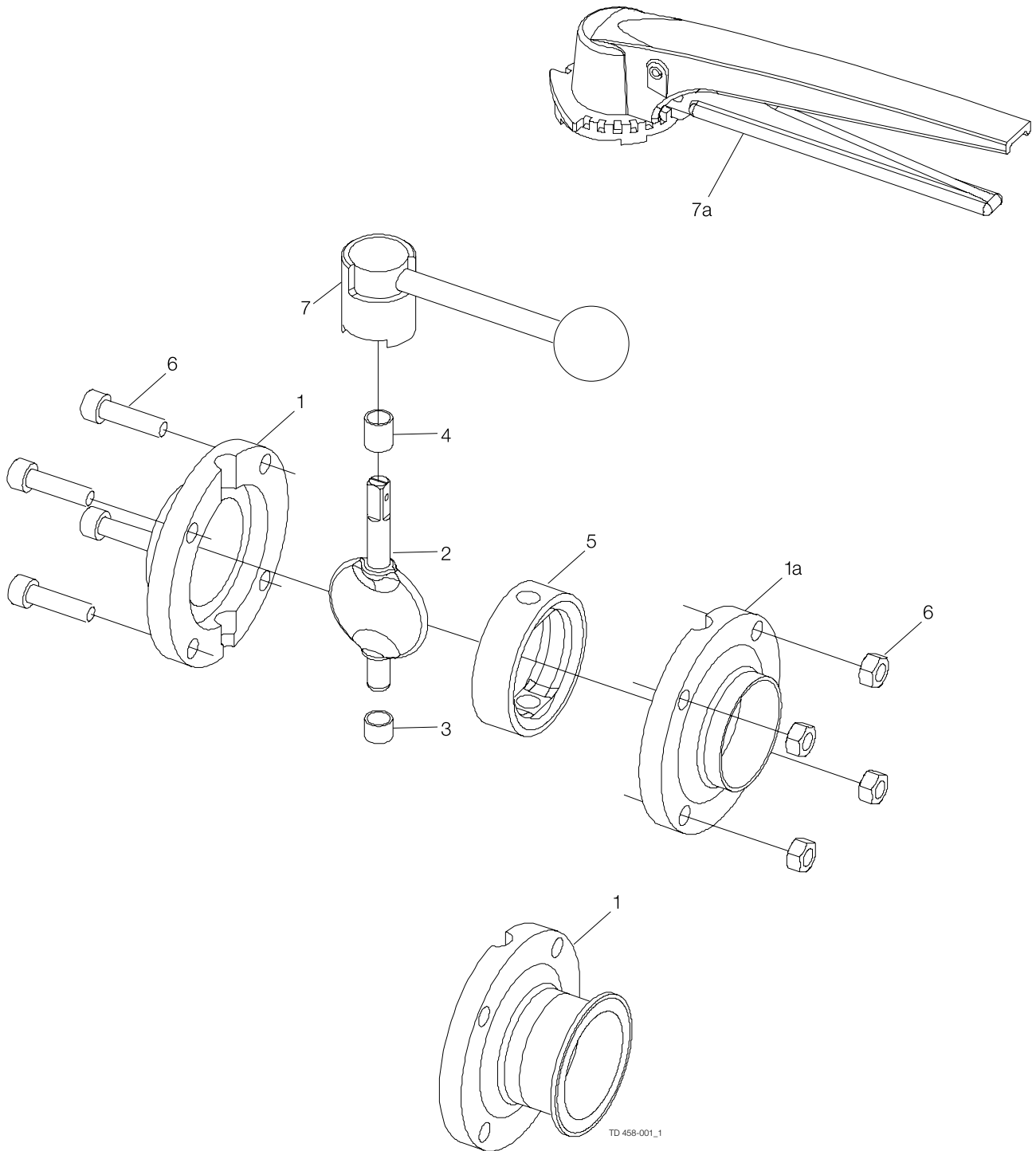

7 Parts list and service kits

The drawing and parts list include all items.

Parts list

Pos.	Qty	Denomination
1	2	Valve body half
2	1	Disc
3	1	Bush
	1	Bush, set (10 pcs.)
4	1	Bush
	1	Bush, set (10 pcs.)
5	1	Seal ring
6	1	Set screw
7	1	Handle
7a	1	Lockable multiposition handle (only ISO)

Service kits

Denomination	25 mm	38 mm	51 mm	63.5 mm	76.1 mm	101.6 mm
Service Kits for product wetted parts, ISO						
□ Service kit EPDM	9611923028	9611923204	9611923205	9611923031	9611923032	9611923033

Service kits

Denomination	DN25	DN40	DN50	DN65	DN80	DN100
Service Kits for product wetted parts, DIN						
□ Service kit EPDM	9611923206	9611923207	9611923208	9611923079	9611923209	9611923218

Parts marked with □ are included in the service kits.
Recommended spare parts: Service kits.

TD 900-204/4

7 Parts list and service kits

The drawing and the parts list include all items.
NO = Normally open.
NC = Normally closed.

7.10 LKLA ø85 mm (NO/NC)

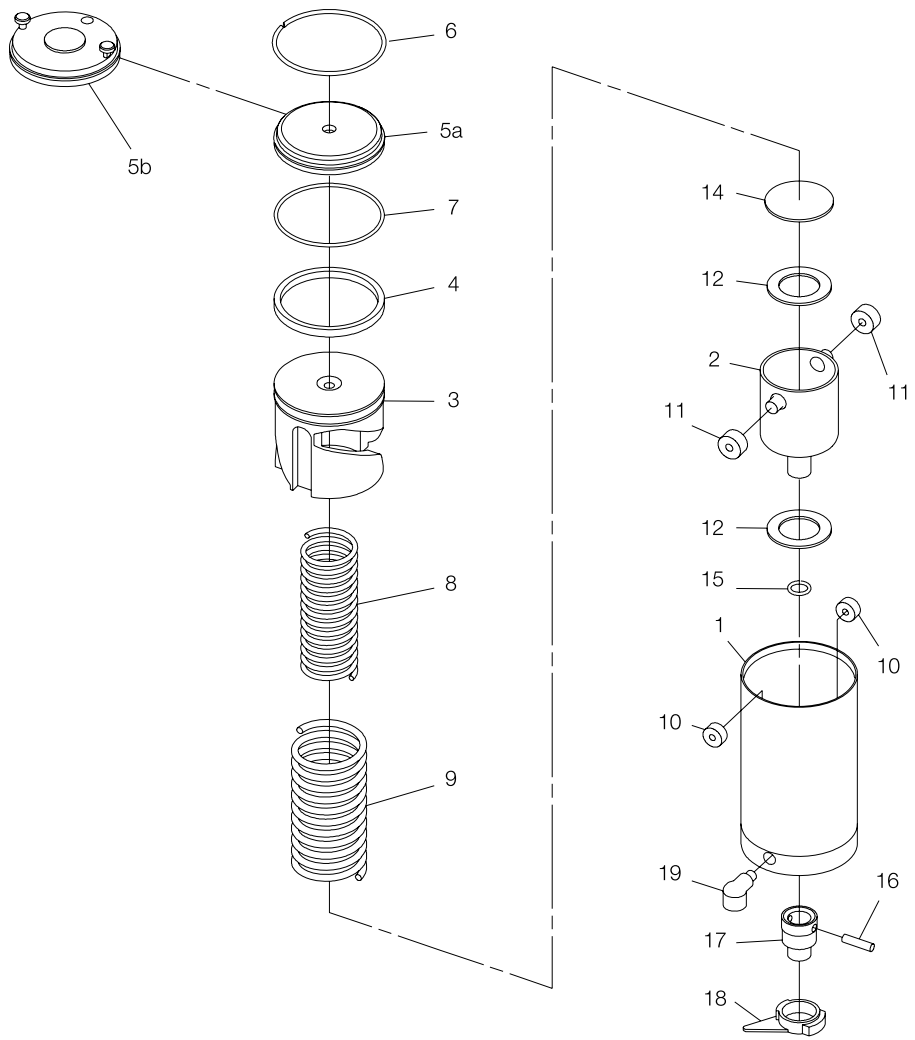

7 Parts list and service kits

The drawing and the parts list include all items.

NO = Normally open.

NC = Normally closed.

Parts list

Pos.	Qty	Denomination
1	1	Air cylinder
2	1	Rotating cylinder
3	1	Piston
4 □	1	O-ring
5a	1	End cap
5b	1	End cap, Mark III
6	1	Retaining ring
7 □	1	O-ring
8	1	Inner spring
9	1	Outer spring
10 □	2	Needle bearing
11 □	2	Needle bearing
12 □	2	Thrust bearing
14	1	Thrust plate
15 □	1	O-ring
16	1	Connex pin
17	1	Coupling
18	1	Activating ring, Noryl with screw
19	1	Water rejector (period 8310-)

Service kits

Service kit for actuator

Service kits, air/spring 9611923010

Note:

Butterfly valve 101.6 mm / DN100 sold before 8906 = □ 10 mm

Butterfly valve DN 65 (ISO) sold before 8910 = □ 8 mm

Please check the square size of the disc when ordering spares.

Parts marked with □ are included in the service kit.

Recommended spare parts: Service kit.

900128/2

7 Parts list and service kits

The drawing and the parts list include all items.

7.11 LKLA ø85 mm (A/A)

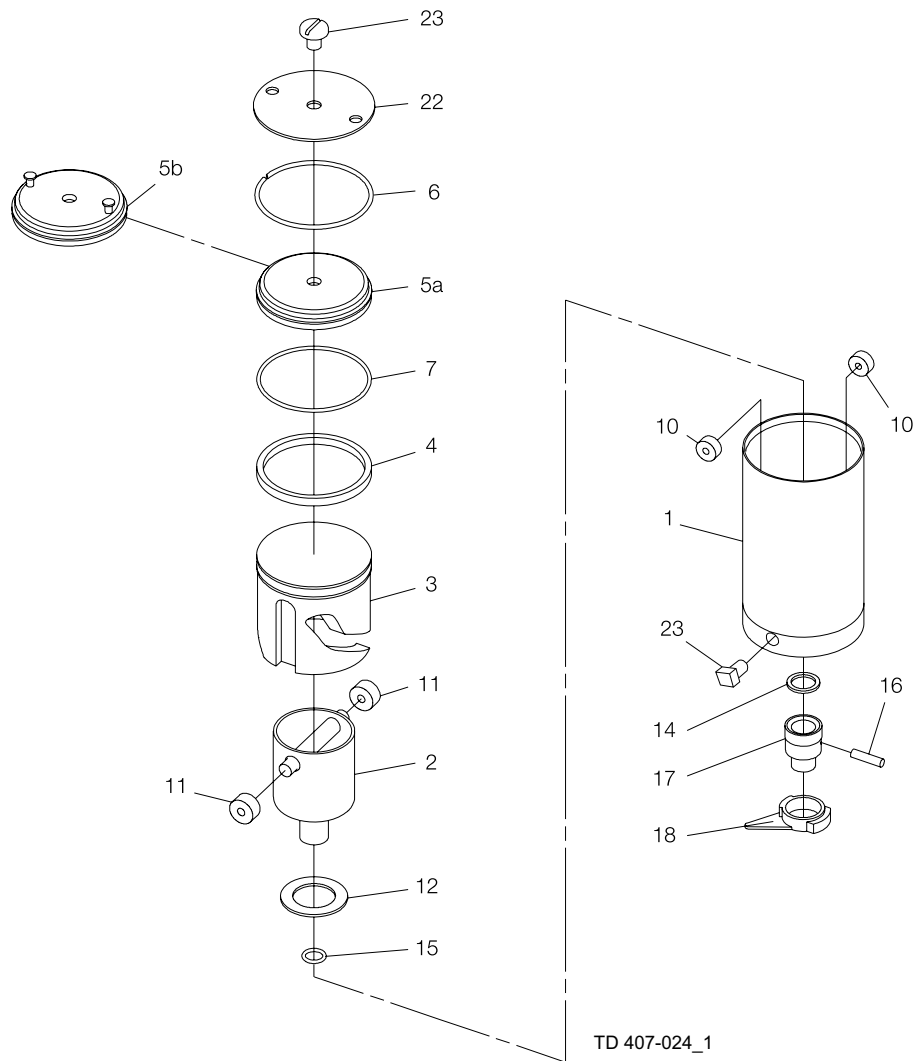

7 Parts list and service kits

The drawing and the parts list include all items.

Parts list

Pos.	Qty	Denomination
1	1	Air cylinder
2	1	Rotating cylinder
3	1	Piston
4 □	1	O-ring
5a	1	End cap
5b	1	End cap, Mark III
6	1	Retaining ring
7 □	1	O-ring
10 □	2	Needle bearing
11 □	2	Needle bearing
12 □	1	Thrust bearing
14	1	Thrust plate
15 □	1	O-ring
16	1	Connex pin
17	1	Coupling
18	1	Activating ring with screw
22***	1	Retaining plate
23	2	Threaded plug

Service kits

Service kits, air/air 9611923011

Note:

*** Up to 8910 supplied without holes, not available anymore
 Butterfly valve 101.6 mm / DN100 sold before 8906 = □ 10 mm
 Butterfly valve DN 65 (ISO) sold before 8910 = □ 8 mm
 Please check the square size of the disc when ordering spares.

Parts marked with □ are included in the service kit.
 Recommended spare parts: Service kit.

900129/1

7 Parts list and service kits

The drawing and the parts list include all items

7.12 LKLA DN 125-150 ø85 mm (A/A)

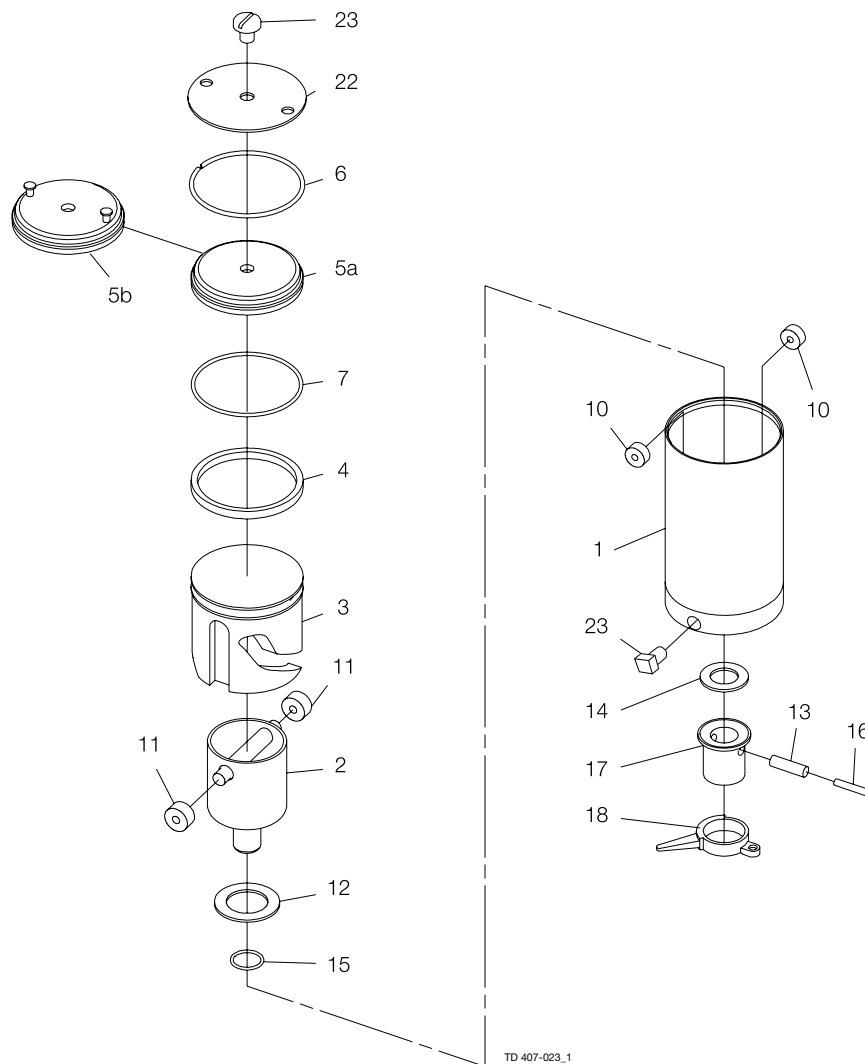

7 Parts list and service kits

The drawing and the parts list include all items

Parts list

Pos.	Qty	Denomination
1	1	Air cylinder
2	1	Rotating cylinder
3	1	Piston
4 □	1	O-ring
5a	1	End cap
5b	1	End cap, Mark III
6	1	Retaining ring
7 □	1	O-ring
10 □	2	Needle bearing
11 □	2	Needle bearing
12 □	1	Thrust bearing
13	1	Connex pin
14	1	Thrust plate
15 □	1	O-ring
16	1	Connex pin
17	1	Coupling
18	1	Activating ring with screw
22***	1	Retaining plate
23	2	Threaded plug

Service kits

Service kits for actuator

Service kits, air/air 9611923012

*** Up to 8910 supplied without holes, not available anymore

Parts marked with □ are included in the service kit.

Recommended spare parts: Service kit.

900130/1

7 Parts list and service kits

The drawing and the parts list include all items.
NO = Normally open.
NC = Normally closed.

7.13 LKLA \varnothing 133 mm (NO/NC)

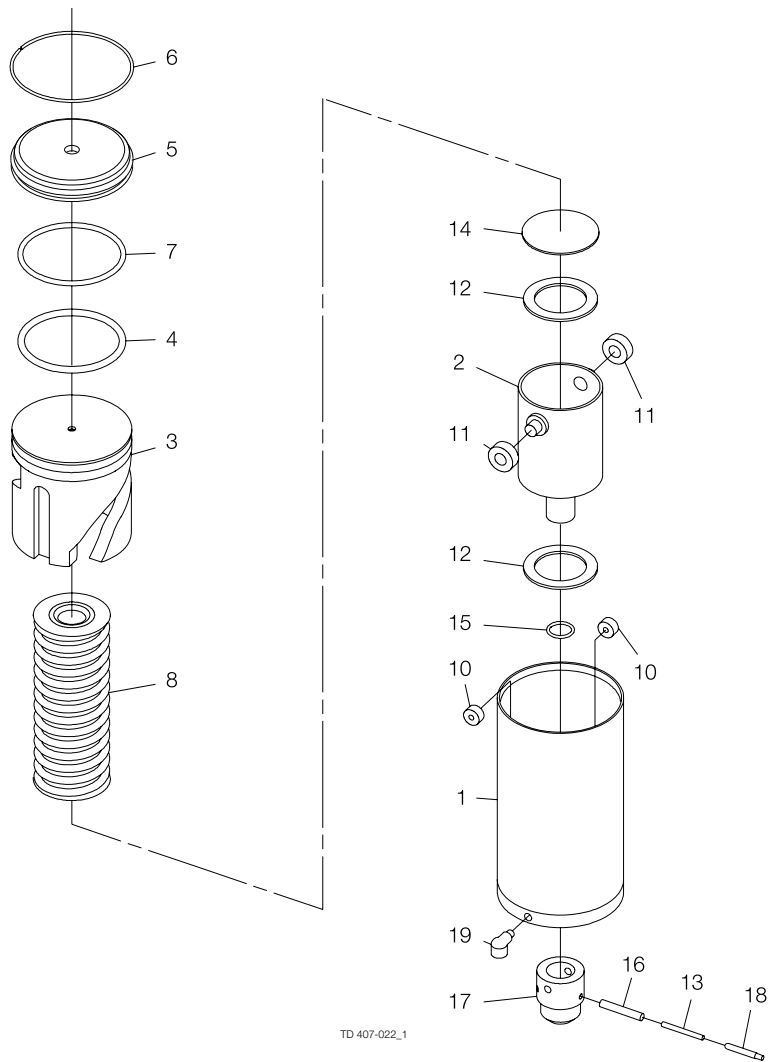

7 Parts list and service kits

The drawing and the parts list include all items.

NO = Normally open.

NC = Normally closed.

Parts list

Pos.	Qty	Denomination
1	1	Air cylinder
2	1	Rotating cylinder
3	1	Piston
4 □	1	O-ring
5	1	End cap
6	1	Retaining ring
7 □	1	O-ring
8	1	Spring assembly
10 □	2	Needle bearing
11 □	2	Needle bearing
12 □	2	Thrust bearing
13	1	Connex pin
14	1	Thrust plate
15 □	1	O-ring
16	1	Connex pin
17	1	Coupling
18	1	Indication pin
19	1	Water rejector

Service kits

Service kits for actuator

Service kits, air/spring 9611923020

Parts marked with □ are included in the service kit.

Recommended spare parts: service kit.

900131

7 Parts list and service kits

The drawing and the parts list include all items.

7.14 LKLA \varnothing 133 mm (A/A)

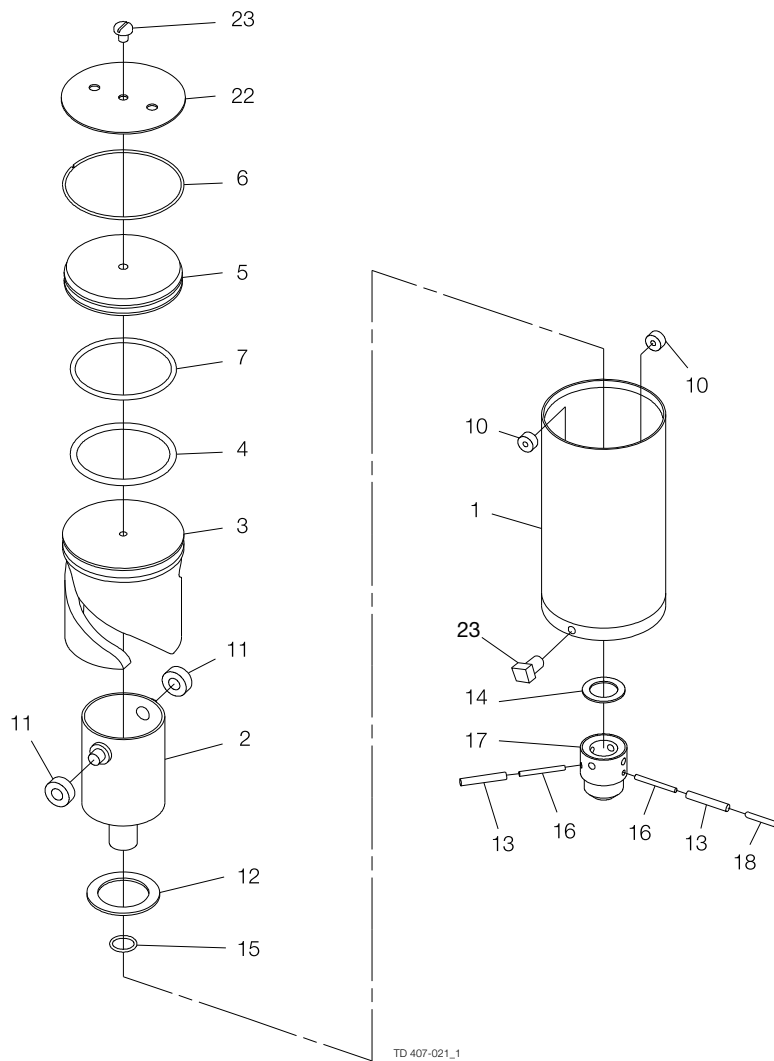

7 Parts list and service kits

The drawing and the parts list include all items.

Parts list

Pos.	Qty	Denomination
1	1	Air Cylinder
2	1	Rotating cylinder
3	1	Piston
4 □	1	O-ring
5	1	End cap
6	1	Retaining ring
7 □	1	O-ring
10 □	2	Needle bearing
11 □	2	Needle bearing
12 □	1	Thrust bearing
13	2	Connex pin
14	1	Thrust plate
15 □	1	O-ring
16	2	Connex pin
17	1	Coupling
18	1	Indication pin
22	1	Retaining plate
23	1	Threaded plug

Service kits

Service kits for actuator

Service kits, air/air 9611923022

Parts marked with □ are included in the service kit.

Recommended spare parts: service kit.

900132/1

7 Parts list and service kits

The drawing and the parts list include all items.

NO = Normally open.

NC = Normally closed.

7.15 LKLA-T ø85 mm (NO/NC)

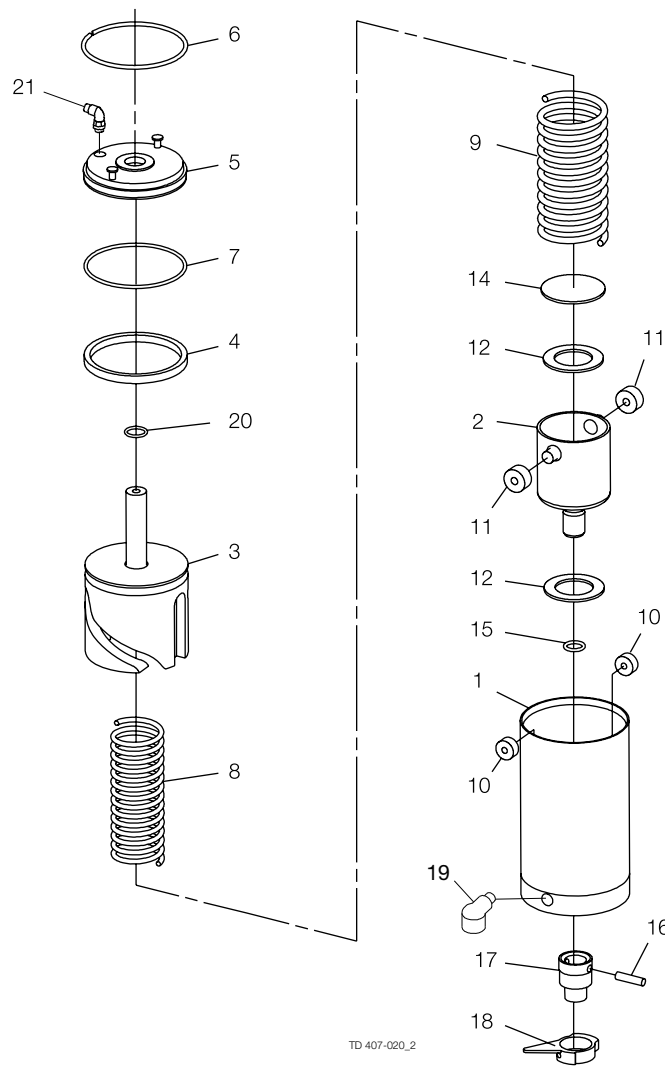

7 Parts list and service kits

The drawing and the parts list include all items.

NO = Normally open.

NC = Normally closed.

Parts list

Pos.	Qty	Denomination
1	1	Air cylinder
2	1	Rotating cylinder
3	1	Piston
4	1	O-ring
5	1	End cap
6	1	Retaining ring
7	1	O-ring
8	1	Inner spring
9	1	Outer spring
10	2	Needle bearing
11	2	Needle bearing
12	2	Thrust bearing
14	1	Thrust plate
15	1	O-ring
16	1	Connex pin
17	1	Coupling
18	1	Activating ring with screw
19	1	Water rejector (period 8310-)
20	1	O-ring
21	1	Air fitting

Service kits

Service kits for actuator

Service kits, air/spring 9611923021

Parts marked with □ are included in the service kit.

Recommended spare parts: service kit.

900133/1



7 Parts list and service kits

The drawing and the parts list include all items.

7.16 LKLA-T ø85 mm (A/A)

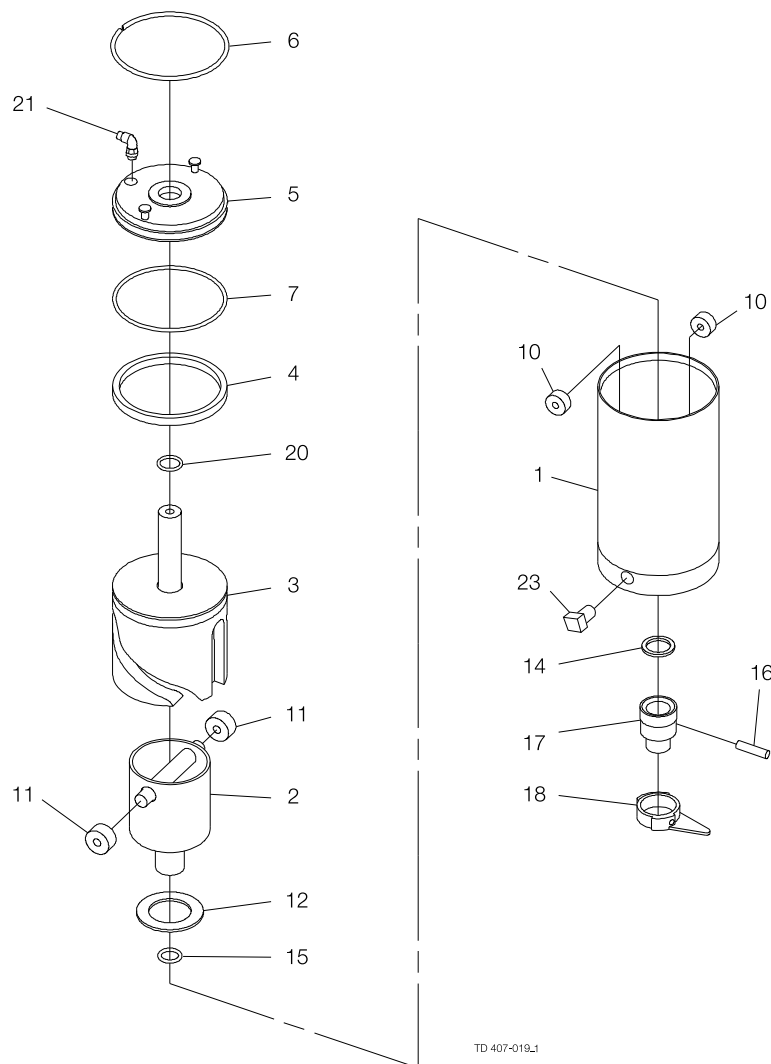

7 Parts list and service kits

The drawing and the parts list include all items.

Parts list

Pos.	Qty	Denomination
1	1	Air cylinder
2	1	Rotating cylinder
3	1	Piston
4 □	1	O-ring
5	1	End cap
6	1	Retaining ring
7 □	1	O-ring
10 □	2	Needle bearing
11 □	2	Needle bearing
12 □	1	Thrust bearing
14	1	Thrust plate
15 □	1	O-ring
16	1	Connex pin
17	1	Coupling
18	1	Activating ring with screw
20 □	1	O-ring
21	1	Air fitting
23	1	Threaded plug

Service kits

Service kits for actuator

Service kits, air/air 9611923023

Parts marked with □ are included in the service kit.

Recommended spare parts: service kit.

900134/1

7 Parts list and service kits

The drawing and the parts list include all items.

7.17 LKLA-T DN 125-150 ø85 mm (A/A)

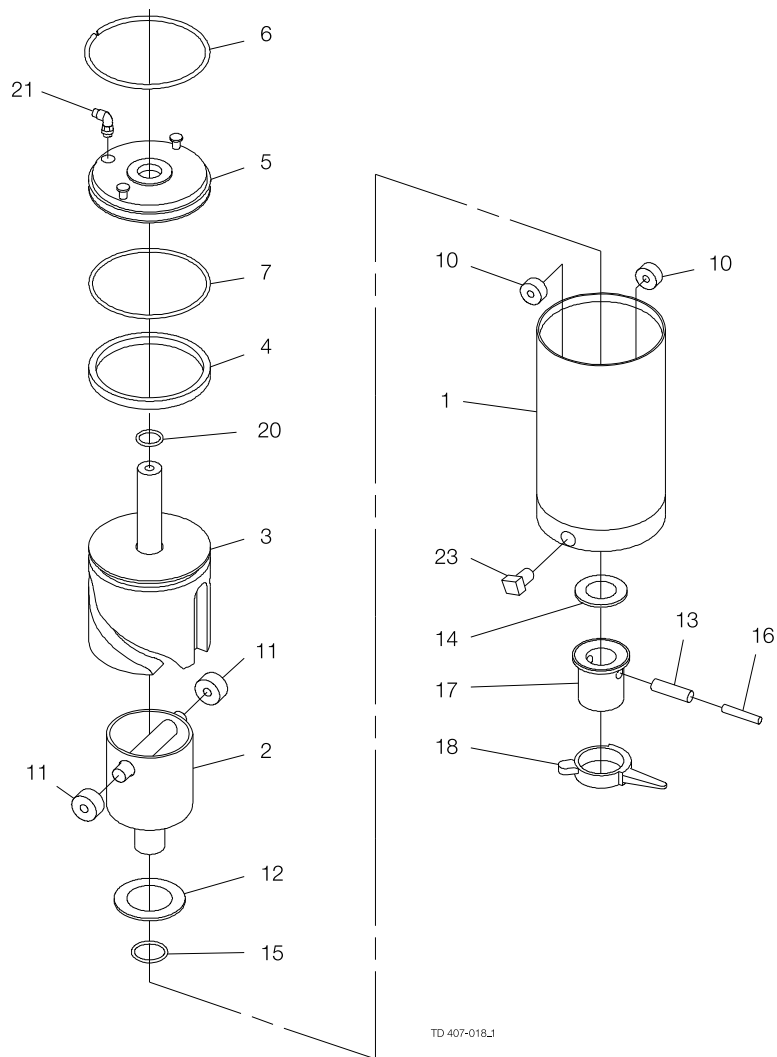

7 Parts list and service kits

The drawing and the parts list include all items.

Parts list

Pos.	Qty	Denomination
1	1	Air cylinder
2	1	Rotating cylinder
3	1	Piston
4 □	1	O-ring
5	1	End cap
6	1	Retaining ring
7 □	1	O-ring
10 □	2	Needle bearing
11 □	2	Needle bearing
12 □	1	Thrust bearing
13	1	Connex pin
14	1	Thrust plate
15 □	1	O-ring
16	1	Connex pin
17	1	Coupling
18	1	Activating ring with screw
20 □	1	O-ring
21	1	Air fitting
23	1	Threaded plug

Service kits

Service kits, air/air 9611923024

Parts marked with □ are included in the service kit.

Recommended spare parts: service kit.

900135/1

7 Parts list and service kits

The drawing and the parts list include all items.
NO = Normally open.
NC = Normally closed.

7.18 LKLA-T ø133 mm (NO/NC)

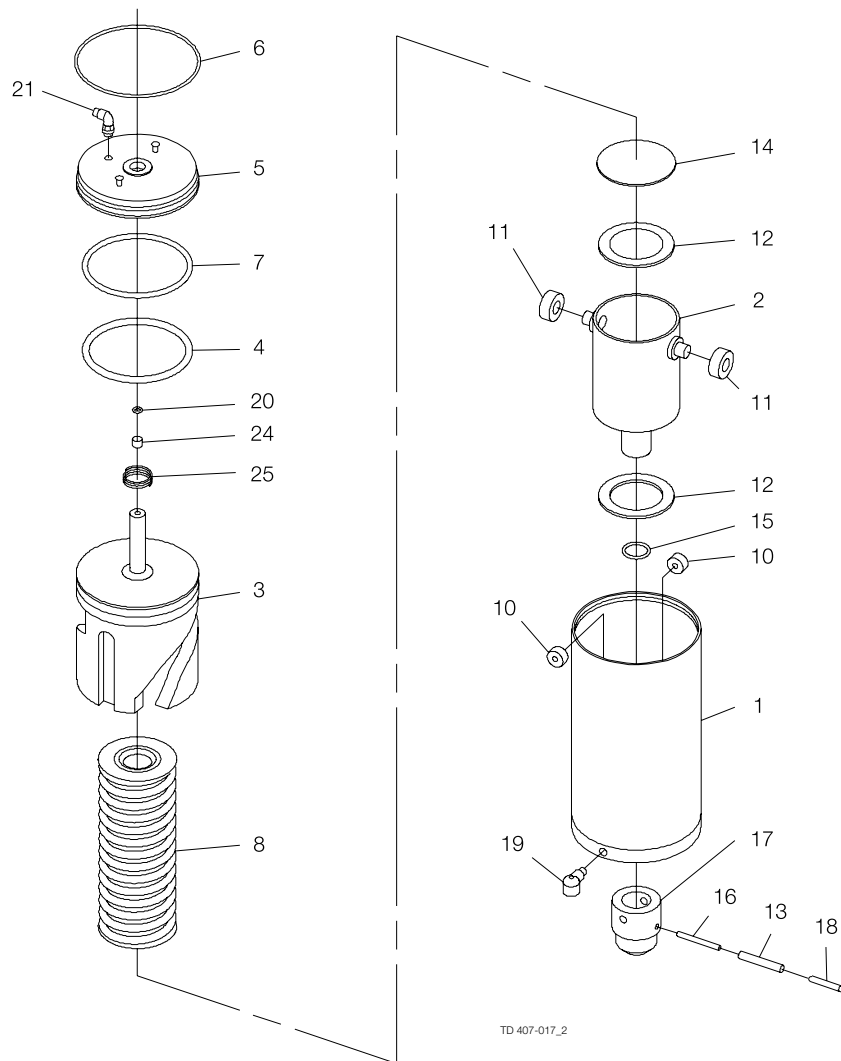

7 Parts list and service kits

The drawing and the parts list include all items.

NO = Normally open.

NC = Normally closed.

Parts list

Pos.	Qty	Denomination
1	1	Air cylinder
2	1	Rotating cylinder
3	1	Piston
4 □	1	O-ring
5	1	End cap
6	1	Retaining ring
7 □	1	O-ring
8	1	Spring assembly
10 □	2	Needle bearing
11 □	2	Needle bearing
12 □	2	Thrust bearing
13	1	Connex pin
14	1	Thrust plate
15 □	1	O-ring
16	1	Connex pin
17	1	Coupling
18	1	Indication pin
19	1	Water rejector (period 8310-)
20 □	1	O-ring
21	1	Air fitting
24 □	1	Guiding ring
25	1	Spring

Service kits

Service kits for actuator

Service kits, air/spring 9611923056

Parts marked with □ are included in the service kit.

Recommended spare parts: service kit.

900136

7 Parts list and service kits

The drawing and the parts list include all items.

7.19 LKLA-T ø133 mm (A/A)

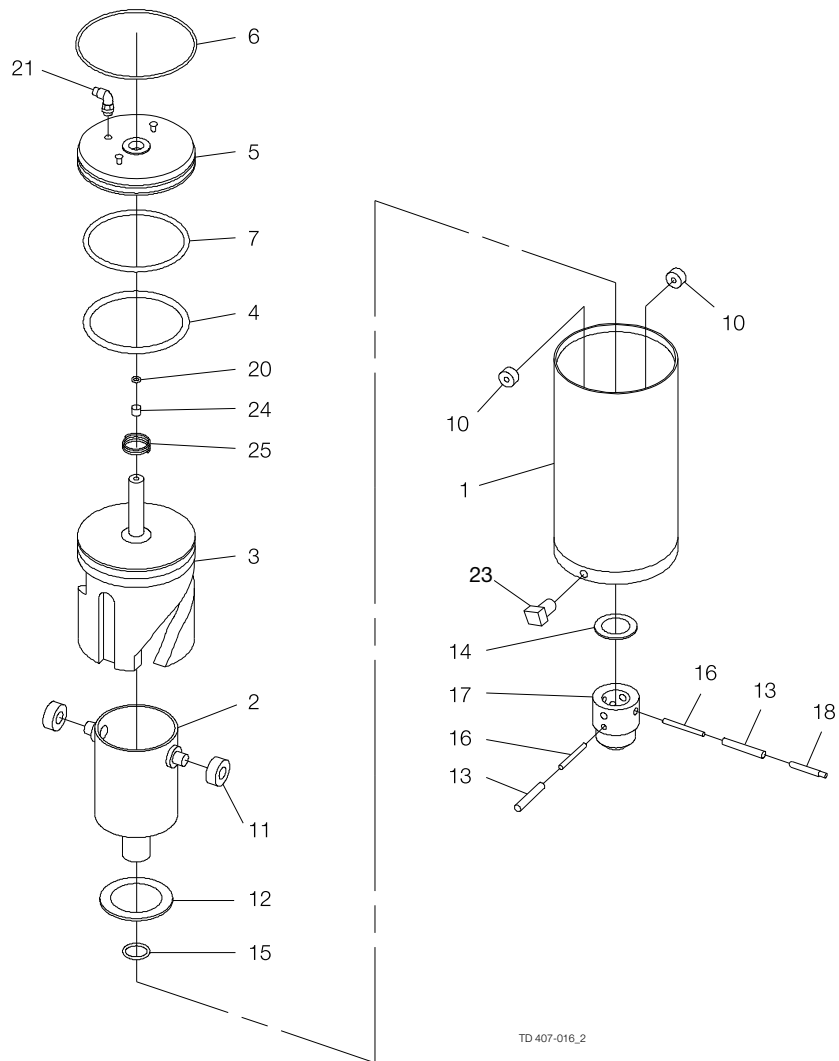

7 Parts list and service kits

The drawing and the parts list include all items.

Parts list

Pos.	Qty	Denomination
1	1	Air cylinder
2	1	Rotating cylinder
3	1	Piston
4	1	O-ring
5	1	End cap
6	1	Retaining ring
7	1	O-ring
10	2	Needle bearing
11	2	Needle bearing
12	1	Thrust bearing
13	2	Connex pin
14	1	Thrust plate
15	1	O-ring
16	2	Connex pin
17	1	Coupling
18	1	Indication pin
20	1	O-ring
21	1	Air fitting
23	1	Threaded plug
24	1	Guiding band
25	1	Spring

Service kits

Service kits for actuator

Service kits, air/air 9611923057

Parts marked with □ are included in the service kit.

Recommended spare parts: service kit.

190137/1

7 Parts list and service kits

The drawing and the parts list include all items.

7.20 LKB lockable multiposition handle for valve

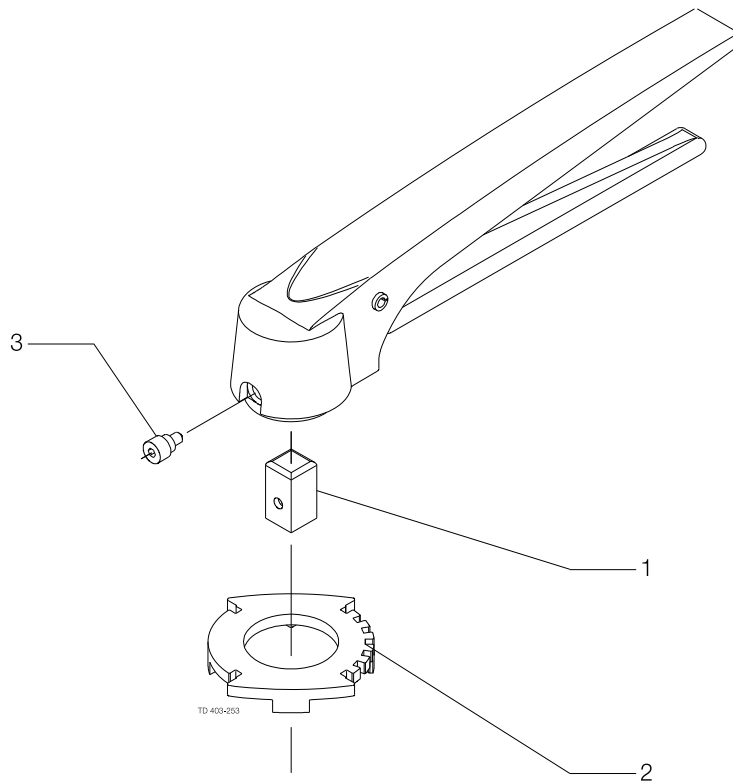

7 Parts list and service kits

The drawing and the parts list include all items.

Parts list

Pos.	Qty	Denomination
1	1	Insert
2	1	Positioning cap
3	1	Screw

7 Parts list and service kits

The drawing and the parts list include all items.

7.21 LKB handle 1.1 for butterfly valve

Handle 1.1 for LKB butterfly valve

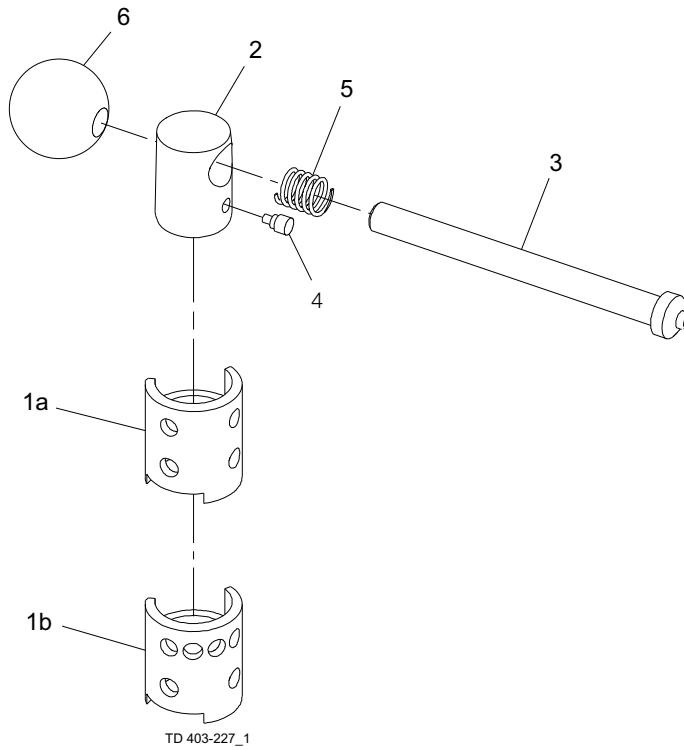

Handle 1.1 with infinite positions for LKB Butterfly valve

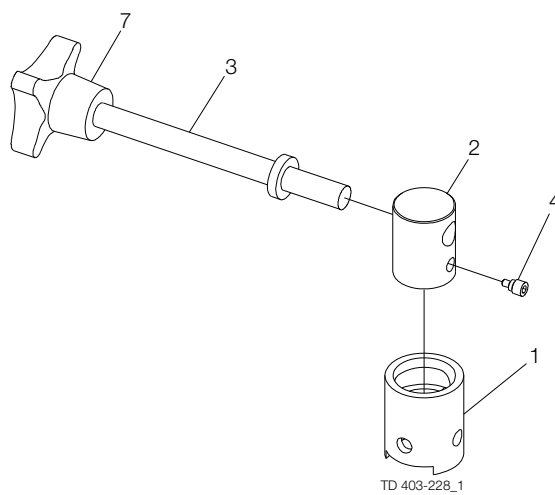

7 Parts list and service kits

The drawing and the parts list include all items.

Parts list

Pos.	Qty	Denomination
2	1	Transfer block
3	1	Handle
4	1	Screw with pin
5	1	Spring
6	1	Ball

7 Parts list and service kits

The drawing and the parts list include all items.

7.22 Handle 1.1 for indication unit

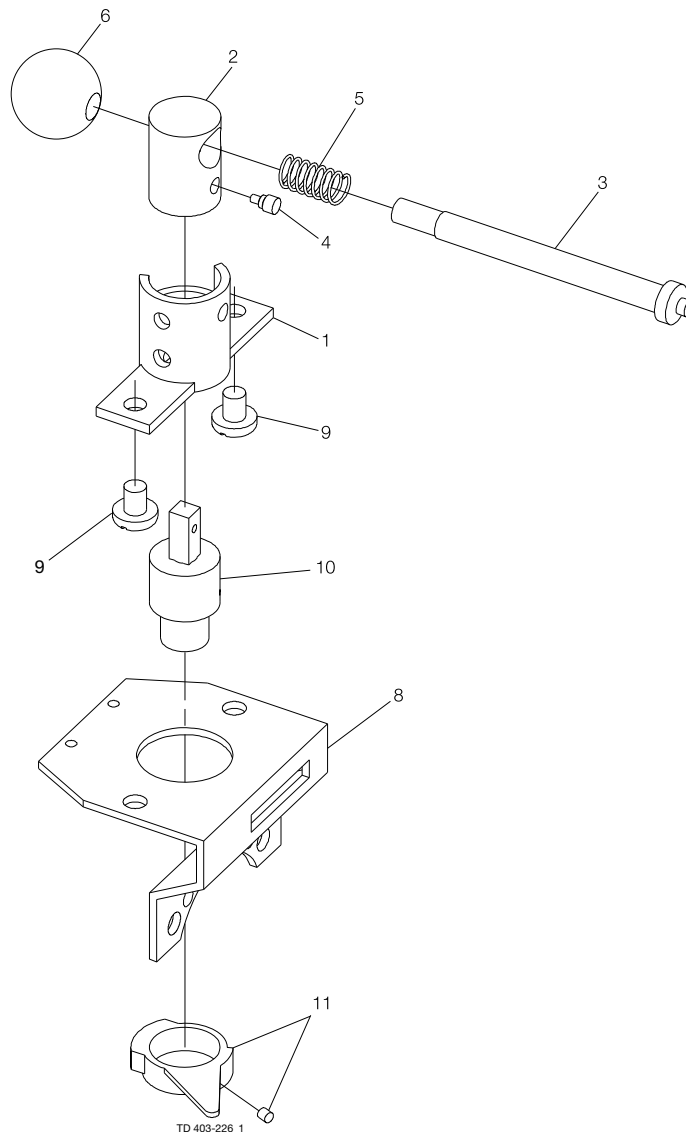

7 Parts list and service kits

The drawing and the parts list include all items.

Parts list

Pos.	Qty	Denomination
1	1	Location cap with 2 pos.
2	1	Transfer block
3	1	Handle
4	1	Screw with pin
5	1	Spring
6	1	Ball
8	1	Bracket
9	2	Screw
10	1	Coupling
11	1	Activating ring with screw

How to contact Alfa Laval

Contact details for all countries are continually updated on our website.

Please visit www.alfalaval.com to access the information directly.

© Alfa Laval Corporate AB

This document and its contents is owned by Alfa Laval Corporate AB and protected by laws governing intellectual property and thereto related rights. It is the responsibility of the user of this document to comply with all applicable intellectual property laws. Without limiting any rights related to this document, no part of this document may be copied, reproduced or transmitted in any form or by any means (electronic, mechanical, photocopying, recording, or otherwise), or for any purpose, without the expressed permission of Alfa Laval Corporate AB. Alfa Laval Corporate AB will enforce its rights related to this document to the fullest extent of the law, including the seeking of criminal prosecution.



CSI

CONTACT CSI FOR MORE INFORMATION | CSIDESIGNS.COM | SALES@CSIDESIGNS.COM | 417.831.1411