

## Alfa Laval D10 and D11 Plug Valves

### Application

The bonded rubber or stainless steel plug valves are used in food and chemical industries and in other installations where a hygienic closing device with minimum pressure drop is required. D10 and D11 plug valves are designed for quick and easy operation. The D10 is a two-way valve, and the D11 is a three-way valve.

### Standard Design

The plug valves are made of stainless steel AISI 304. They are produced with a strong, rigid body made from drop forged homogeneous material, and the plug is rubber coated. An optional chrome plated and lapped metal plug is available. The plug valves may be supplied with weld connections, clamps or threaded connections.



### TECHNICAL DATA

Maximum working pressure (68° F) . . . 25 PSI  
 Maximum test pressure (68° F) . . . . . 25 PSI  
 Maximum temperature . . . . . 100° F  
 Minimum temperature . . . . . -4° F

### Ordering

Please state the following when ordering:

- Connections  
Tri-Clamp®, Bevel Seat, weld
- Type  
Straight-through valve D10, three-way valve D11, tank outlet valve D10F and D10FL legal tank pasteurization valve
- Plug  
Bonded rubber (Buna) or stainless steel. D10FL only available with stainless steel plug
- Size  
Following sizes are available: 1-inch, 1.5-inch, 2-inch, 2.5-inch, 3-inch

### PHYSICAL DATA

#### Materials

Steel parts . . . . . AISI 304  
 Finish . . . . .  $\leq$  Ra 32  $\mu$ m  
 Rubber parts . . . . . Buna (N)

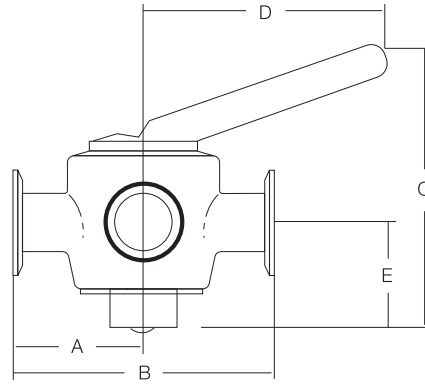
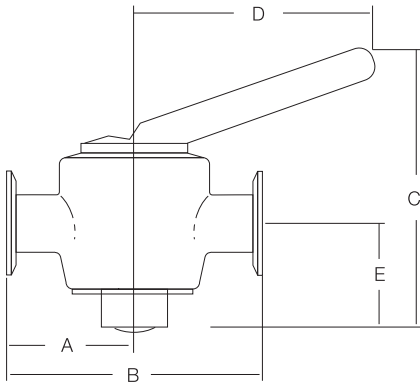

**Dimensions Tri-Clamp® connections**

Size (Tube OD)		A		B		C		D		E		Approx. Wt.	
inch	mm	inch	mm	inch	mm	inch	mm	inch	mm	inch	mm	lb	kg
1½	38.1	22 <sup>9</sup> / <sub>32</sub>	73.8	5 <sup>13</sup> / <sub>16</sub>	147.6	7	177.8	5 <sup>5</sup> / <sub>8</sub>	142.9	2½	63.5	9.50	4.30
2	50.8	31 <sup>3</sup> / <sub>32</sub>	86.5	6 <sup>13</sup> / <sub>16</sub>	173.0	7 <sup>5</sup> / <sub>8</sub>	193.7	5 <sup>5</sup> / <sub>8</sub>	142.9	2 <sup>7</sup> / <sub>8</sub>	73.0	15.50	7.03
2½	63.5	4 <sup>1</sup> / <sub>8</sub>	104.8	8¼	209.6	8¾	222.3	6¼	158.8	3½	88.9	25.50	11.56
3	76.2	4 <sup>23</sup> / <sub>32</sub>	119.9	9 <sup>7</sup> / <sub>16</sub>	239.7	9¾	247.7	7¼	184.2	3¾	95.3	36.00	16.32

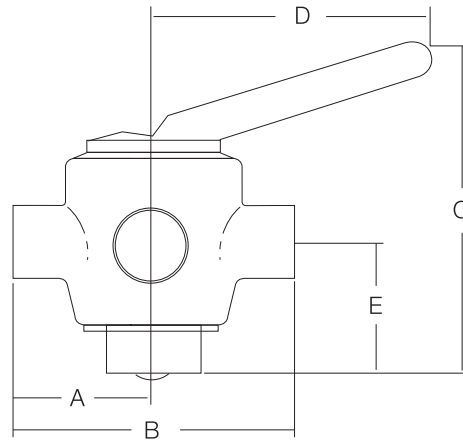
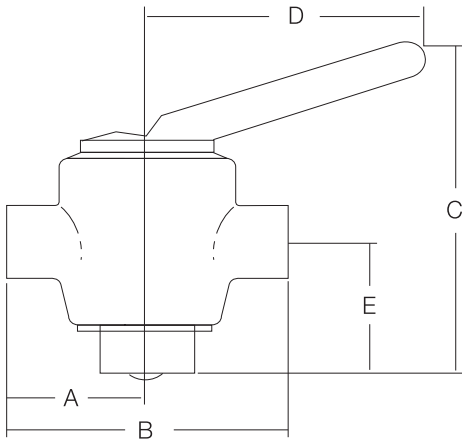

**Dimensions Weld connections**

Size (Tube OD)		A		B		C		D		E		Approx. Wt.	
inch	mm	inch	mm	inch	mm	inch	mm	inch	mm	inch	mm	lb	kg
1½	38.1	2 <sup>3</sup> / <sub>32</sub>	69.1	5 <sup>7</sup> / <sub>16</sub>	138.1	6 <sup>7</sup> / <sub>8</sub>	177.8	5 <sup>5</sup> / <sub>8</sub>	142.9	2½	63.5	9.50	4.30
2	50.8	3 <sup>3</sup> / <sub>16</sub>	81.0	6 <sup>3</sup> / <sub>8</sub>	161.9	7 <sup>5</sup> / <sub>8</sub>	193.7	5 <sup>5</sup> / <sub>8</sub>	142.9	2 <sup>7</sup> / <sub>8</sub>	73.0	15.50	7.03
2½	63.5	4 <sup>7</sup> / <sub>8</sub>	123.8	7¼	196.9	8 <sup>5</sup> / <sub>8</sub>	222.3	6¼	158.8	3½	88.9	25.50	11.56
3	76.2	4 <sup>15</sup> / <sub>32</sub>	113.5	8 <sup>15</sup> / <sub>16</sub>	227.0	9¾	247.7	7¼	184.2	3¾	95.3	36.00	16.32



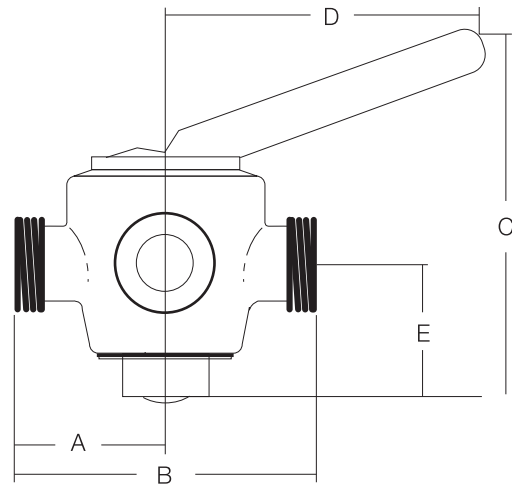
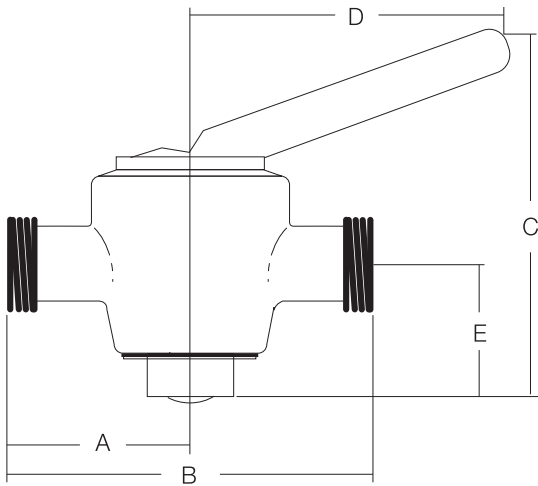

**Dimensions Bevel Seat connections**

Size (Tube OD)		A		B		C		D		E		Approx. Wt.	
inch	mm	inch	mm	inch	mm	inch	mm	inch	mm	inch	mm	lb	kg
1½	38.1	2 <sup>29</sup> / <sub>32</sub>	73.8	5 <sup>13</sup> / <sub>16</sub>	147.6	6 <sup>7</sup> / <sub>8</sub>	174.6	5 <sup>5</sup> / <sub>8</sub>	142.9	2½	63.5	9.50	4.31
2	50.8	3 <sup>13</sup> / <sub>32</sub>	86.5	6 <sup>13</sup> / <sub>16</sub>	173.0	7 <sup>5</sup> / <sub>8</sub>	193.7	5 <sup>5</sup> / <sub>8</sub>	142.9	2 <sup>7</sup> / <sub>8</sub>	73.0	15.50	7.03
2½	63.5	4 <sup>1</sup> / <sub>8</sub>	104.8	8¼	209.6	8 <sup>5</sup> / <sub>8</sub>	219.1	6¼	158.8	3½	88.9	25.50	11.56
3	76.2	4 <sup>23</sup> / <sub>32</sub>	119.9	9 <sup>7</sup> / <sub>16</sub>	239.7	9¾	247.3	7¼	184.2	3¾	93.7	36.00	16.33

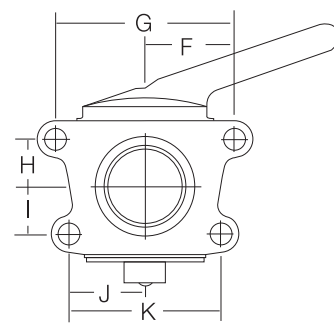
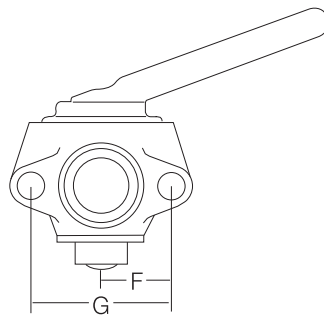
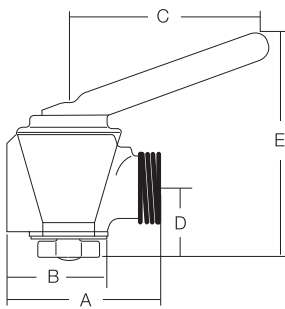

**Dimensions (inches) Plug Valve Tank - D10F and D10FL**

Size (Tube OD)	A	B	C	D	E	F	G	H	I	J	K	Hole Size	Approx. Wt.	
1½	4 <sup>5</sup> / <sub>16</sub>	3 <sup>1</sup> / <sub>8</sub>	5 <sup>5</sup> / <sub>8</sub>	2 <sup>3</sup> / <sub>8</sub>	6¼	1 <sup>23</sup> / <sub>32</sub>	3 <sup>7</sup> / <sub>16</sub>	--	--	--	--	9/16	9.50	4.30
2	5 <sup>7</sup> / <sub>16</sub>	4 <sup>1</sup> / <sub>8</sub>	5 <sup>5</sup> / <sub>8</sub>	2¾	7½	2 <sup>1</sup> / <sub>8</sub>	4¼	--	--	--	--	9/16	15.50	7.03
2½	6¾	4 <sup>5</sup> / <sub>8</sub>	6¼	3½	8¾	2 <sup>5</sup> / <sub>8</sub>	5¼	1 <sup>5</sup> / <sub>16</sub>	1½	2½	5	9/16	25.50	11.56
3	8	4¾	7¼	3¾	9¾	3 <sup>5</sup> / <sub>16</sub>	6 <sup>5</sup> / <sub>8</sub>	1¾	1¾	2 <sup>13</sup> / <sub>16</sub>	5 <sup>5</sup> / <sub>8</sub>	11/16	36.00	16.32

**Dimensions (mm) Plug Valve Tank - D10F and D10FL**

Size (Tube OD)	A	B	C	D	E	F	G	H	I	J	K	Hole Size	Approx. Wt.	
1½	109.5	79.4	142.9	60.3	171.5	43.7	87.3	--	--	--	--	14.3	9.5	4.30
2	138.1	104.8	142.9	69.9	190.5	54.0	108.0	--	--	--	--	14.3	15.5	7.03
2½	171.5	117.5	158.8	88.1	222.3	66.7	133.4	33.3	38.1	63.5	127.0	14.3	25.5	11.56
3	203.2	120.7	184.2	95.3	247.7	84.1	168.3	44.5	44.5	71.4	142.9	17.5	36.0	16.32



Alfa Laval reserves the right to change specifications without prior notification.

---

**How to contact Alfa Laval**

Contact details for all countries are continually updated on our website. Please visit [www.alfalaval.us](http://www.alfalaval.us) to access the information direct.



**CSI**

CONTACT CSI FOR MORE INFORMATION | [CSIDESIGNS.COM](http://CSIDESIGNS.COM) | [SALES@CSIDESIGNS.COM](mailto:SALES@CSIDESIGNS.COM) | 417.831.1411