

# Operating Instructions

## AXIFLOW

### Twin Screw Pump



**AXIFLOW**   
**TECHNOLOGIES, INC.**



**CSI**

417.831.1411 • [csidesigns.com](http://csidesigns.com)

**Index**

**1. General information .....4**

**1.1 Information about these operating instructions .....4**

**1.2 Intended use .....4**

**1.3 Scope of supply.....5**

**1.4. Other applicable documents .....6**

**2. Safety .....6**

**2.1 General information .....6**

**2.2 Risks resulting from non-compliance with the safety instructions.....6**

**2.3 Installation, operating and maintenance personnel .....6**

**2.4 Safety devices .....7**

**2.5 Conversion of the system/pump and use of spare parts.....7**

**3. Design and mode of operation .....7**

**3.1 Pump design .....7**

**3.2 Design of the pump assembly unit.....8**

**3.3 Mode of operation of the pump .....9**

**3.4 Nameplate.....9**

**4. Transportation and interim storage.....10**

**5. Erection and installation .....10**

**5.1 Fitting the pump on the unit console .....10**

**5.2 Piping .....11**

**5.3 Electrical connection .....11**

**6. Pump/system operation .....12**

**6.1 Initial startup .....12**

**6.2 Shutting down .....12**

**6.3 Restarting .....13**

**7. Servicing and cleaning .....13**

**7.1 Maintenance .....13**

**7.2 Inspection and maintenance table .....13**

**7.3 Cleaning/sterilizing .....15**

**8. Malfunctions / causes / rectification .....18**

**9. Servicing, spare parts, accessories .....19**

**Appendix.....20**

## **1. General Information**

### **1.1 Information about these operating instructions**

These operating instructions contain basic instructions for installation, operation and servicing. They must read before installation and initial start-up by the responsible user/operator and must always be available at the installation location since no liability will be assumed for any damage or operational malfunctions arising from non-compliance with these operating instructions.

### **1.2 Intended use**

The pump is solely to be used for the pumping of the media agreed in the order datasheet. Any other application that goes beyond the intended use or conversion of the pump without written agreement with the manufacturer shall be deemed to be not in accordance with the intended use.

The pump may only be started up for the first time if it has been ensured that all safety devices are completely fitted and functional.

In areas subject to risk of explosion only pumps designed to the relevant explosion-proof specification may be used.

Intended use also covers compliance with the conditions of operation, servicing and maintenance specified by the manufacturer.

The pump is only capable of dry running for a short time. The occurrence of dry running phases should therefore be avoided or agreed in advance with the manufacturer.

The pump is only to be put into operation filled with medium to be pumped.

Before starting up ensure that:

- ❖ the valves on the inlet side open completely (to avoid cavitation)
- ❖ the valves on the outlet side open completely (to avoid exceeding the permitted differential pressure of the pump)
- ❖ outlet-side safety measures are taken (e.g. safety valve) to protect the pump from non-permitted excess pressure

### 1.3 Scope of supply

The pump can:

- ❖ be ordered with a free shaft end, i.e. the pump is supplied without motor or base plate,

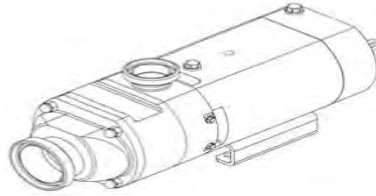

- ❖ be ordered as an assembled unit, i.e. ready-assembled on base plate with drive motor, coupling and coupling protection

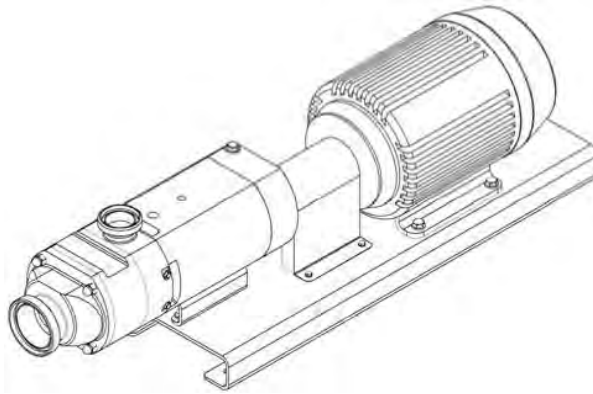

- ❖ with Nema C-Face design, i.e. pump with flange-fitted motor

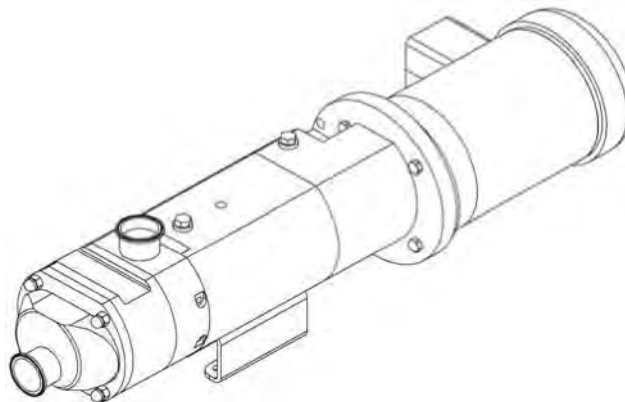

Immediately on receipt of the pump, ensure it is complete and report any damage or defects to the delivery company.

**1.4 Other applicable documents**

Pump datasheet	Technical data, conditions for use, performance and operating limits
Dimensional drawing	Designation of components and connections
Spare parts lists	Spare parts ordering
Supplementary sheet	Mechanical seal system technical data
Disassembly/assembly instructions	Disassembly and assembly of the pump
Vendor documentation	Technical documentation for vendor parts

**2. Safety**

**2.1 General information**

The pump is only to be operated when in perfect working order. It is also only to be operated in accordance with its intended use and with regard to safety and risk aspects in compliance with these instructions.

Instructions attached to the machine shall be maintained in their entirety and legibly.

Working methods that endanger personnel or non-involved third parties shall be avoided.

In the event of safety-relevant malfunctions, the pump shall be shut down immediately and the malfunction shall be rectified by the responsible person.

The safety regulations of the relevant operator country also apply.

The pump has to be protected against access by non-qualified personnel.

**2.2 Risks resulting from non-compliance with the safety instructions**

Non-compliance with the safety instructions can cause a risk to individuals, the environment and to the pump itself.

**2.3 Installation, operating and maintenance personnel**

Installation, operating and maintenance personnel are those persons who are responsible for the shipment, assembly, installation, operation, cleaning and correction of problems.

The operator must ensure that authorized and properly qualified personnel perform all maintenance, operating and installation activities.

Work on the system should only be performed when it is shut down. Immediately following the conclusion of such work, all safety and protective devices must be made functional.

## 2.4 Safety devices

Ensure provision of the following safety devices and their functionality:

- ❖ For hot, cold and moving parts: provide on-site protection against accidental contact with the pump, which must not be removed during operation
- ❖ For possible electrostatic discharge: provide relevant grounding system
- ❖ Provide suitable pressure relief devices to prevent outlet-side excess pressure between the pump and the first shut-off device

## 2.5 Conversion of the system/pump and use of spare parts

Modifications or conversions of the system/pump will only be warranted following agreement with the manufacturer.

For safety and functional reasons, spare parts from the manufacturer shall only be used. The use of other parts voids any warranty and excludes liability for any resulting consequences.

## 3. Design and Mode of Operation

### 3.1 Pump design

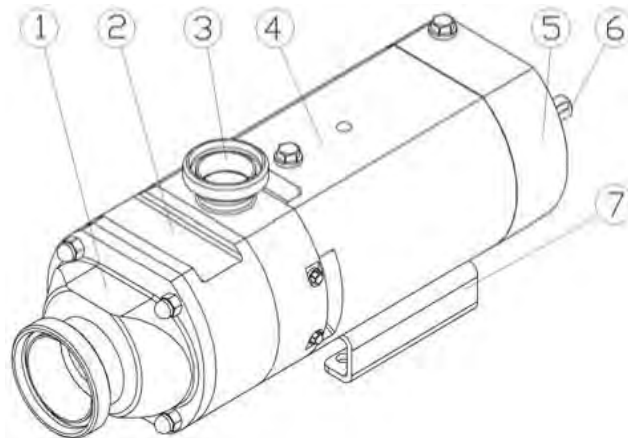

The following parts of the pump are visible externally:

1. Cover with connector (normally inlet)
2. Pump casing
3. Intermediate flange with connector (normally outlet)

4. Bearing casing
5. Gear casing
6. Drive shaft
7. Pump console

With Nema C-Face type pumps, the drive shaft is not visible as the drive unit is flange-mounted directly to the gear casing.

Under certain circumstances, the direction of flow can be reversed. In such cases, #1 is the outlet nozzle and #3 is the inlet nozzle.

### 3.2 Design of the pump assembly unit

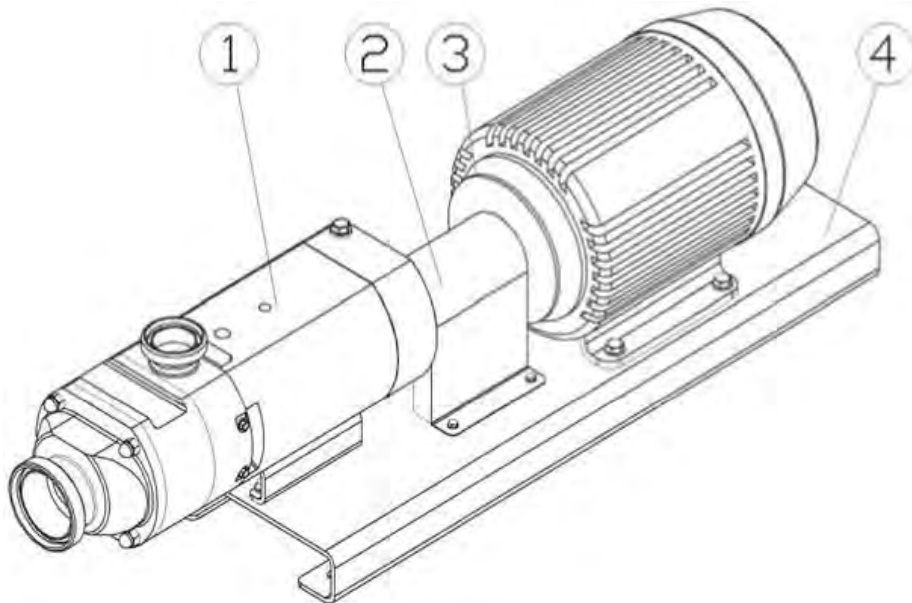

A pump assembly unit consists of the following parts:

1. Pump
2. Coupling and coupling protection
3. Drive unit
4. Console



### 3.3 Mode of operation of the pump

AXIFLOW pumps are externally mounted bearings, single entry, twin-screw pumps. The pumping elements move the medium from the pump inlet to the outlet without coming into contact with it. Reverse operation is possible (see assembly/disassembly instructions).



The product chamber is separated from the environment by shaft seals.

The following shaft seals can be fitted:

- ❖ Single-acting mechanical seal without shaft seal ring
- ❖ Single-acting mechanical seal with shaft seal ring and pressure-less quench
- ❖ Double-acting mechanical seal with quench or barrier system

### 3.4 Nameplate

The nameplate is fixed to the bearing casing. Example:

<b>AXIFLOW </b> <b>TECHNOLOGIES, INC.</b> <small>www.axiflowtechnologies.com</small>		1955 VAUGHN ROAD SUITE 103 KENNESAW, GEORGIA 30144 TELEPHONE: (800) 889-5699 FAX: (877) 569-0775	 <small>02-10</small>
<b>Order No.</b>	PTS 1111013	<b>Serial No.</b>	11211-001
<b>Model No.</b>	STS 90-38	<b>Tag No.</b>	Barbecue Sauce Transfer
<b>Product</b>	Barbecue Sauce/CIP	<b>Viscosity</b>	1 - 1,500 CST
<b>Flowrate</b>	60 - 125 GPM	<b>Speed</b>	747 - 1,770 RPM
<b>Power Requirement</b>	7.3 HP	<b>Max. Differential Pressure</b>	40 PSIG
<b>Max. NPSH Requirement</b>	2.86 FEET	<b>Temperature</b>	80 - 180 DEG. F

## 4. Transportation and Interim Storage

The pumps need to be transported and secured with care to ensure no damage is caused. Lifting equipment and load securing straps must be placed for the total weight of the pump/assembly unit. Attach lifting device as shown in the following diagrams:

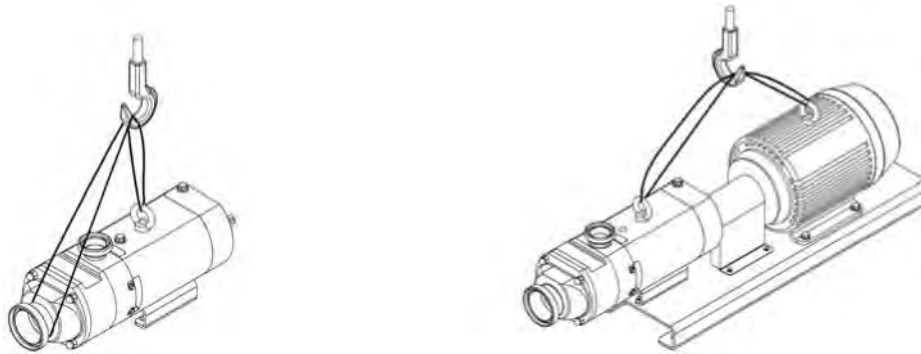

Make sure you set the pump down on a sufficiently stable, horizontal surface.

If stored temporarily, the pump must not be exposed to the weather for any significant period of time. All openings shall be closed with blind flanges, blind plugs or plastic covers. Rotate shaft once a month to change the position of the bearings.

## 5. Erection and Installation

The NEMA additional instructions apply for pumps in areas subject to the risk of explosion. Before fitting the motor, check the direction of rotation.

### 5.1 Fitting the pump on the unit console

Misalignments of the shafts of the pump and drive unit lead to increased wear for bearings, mechanical seals, shaft seal rings, elastic coupling elements and cause the unit to run unevenly.

The pump is aligned with the aid of a spirit level at the drive shaft and at the connecting piece of the intermediate flange.

When assembling the coupling, fit the keys and slide on the coupling halves without tilting.

Do not subject pump or motor components to any jolts or impacts.

Tighten the threaded pins at the coupling halves.

If there is any vertical, horizontal or angular displacement, align the motor precisely to the pump. For detailed information and for special couplings, please refer to the manufacturer's instructions.

Check the light gap over the two coupling halves at the circumference in two planes (at 90° to each other).

If there is a light gap, align the motor at the external diameter.

Check the axial gap between the coupling halves with a feeler gauge, compare with the permitted gap (dimensional drawing) and align if not correct. The axial gap between the coupling halves must be identical measured along the entire circumference.

Fit the coupling guard. If using a protective cover, ensure that there is a gap for ventilating the unit.

## **5.2 Piping**

The installation of the piping must be stress-free and pressure-tight. It needs to be connected so that no forces or moments are transferred to the pump connections. The pump must not be used as a fixing point for the piping. The pipes shall be supported directly before the pump and connected without stress. Any changes in the length of piping resulting from temperature changes shall be compensated by suitable measures in order not to put load on the pump.

In order to avoid the formation of air pockets, the intake line shall be installed ascending, in case of positive intake pressure descending. The intake line shall be dimensioned so that as far as possible the flow speed does not exceed 1.5 m/sec in production mode.

Venting elements shall be provided at the intake and discharge sides.

Sudden changes to the cross-section and direction of the piping run are to be avoided.

Adapters to larger nominal widths should be designed with approx. 8° expansion angle in order to avoid increased pressure losses.

Before initial startup the tanks/containers, piping and connections shall be cleaned thoroughly in order to remove residual weld spatter, scale and other contaminants.

A non-return valve between the pressure nozzle and gate valve shall be used to ensure that the medium does not flow back after switching off the pump.

## **5.3 Electrical connection**

A trained electrician shall perform the electrical connection.

Ensure correct direction of rotation.

Before starting any works at the electrical equipment, the pump has to be de-energized and locked out against re-starting.

Connect the motor with suitable cable bushings in accordance with the wiring diagram – use of cable transversal sections according to the motor parameters.

The connecting cables have to be laid with protection devices. To avoid overheating, connect PTC thermistors of the standard motors, in case of need assemble motor protection switches.

When using other motors than those supplied, the user is self-responsible for safety and function.

## **6. Pump/System Operation**

### **6.1 Initial startup**

- ❖ Check gear lubrication and top up if necessary
- ❖ Prepare auxiliary operating systems if present
- ❖ Check seal system – follow additional instructions of the seal manufacturer
- ❖ Connect heating if present
- ❖ Connect cooling system if present
- ❖ If necessary, clean/sterilize pump
- ❖ Open valves in the intake and discharge lines
- ❖ Fill pump with pumping medium and check visually for leaks
- ❖ Vent lines
- ❖ Switch on motor and set operating speed
- ❖ After achieving the operating speed, check visually for leaks

### **6.2 Shutting down**

- ❖ Switch off motor
- ❖ Check that it slows down smoothly
- ❖ If present, maintain the following functions
  - with double mechanical seals: barrier pressure until pump is depressurized
  - cooling water feed until pump operating temperature < 210 °F

- ❖ If the pump is not going to be used for a relatively lengthy period, close intake and discharge-side valves
- ❖ Switch off heating system if present
- ❖ If necessary, clean/sterilize pump

### **6.3 Restarting**

Before restarting, check that the pump is running smoothly.

## **7. Servicing and Cleaning**

The pump has to be de-energized during maintenances and repairs and locked out against re-starting.

### **7.1 Maintenance**

The pump should always operate smoothly and free of vibrations. The following conditions must be met for problem-free operation:

- ❖ Avoid dry running unless fitted with the proper seal flush
- ❖ Avoid cavitation – always keep shut-off devices in the intake line open during operation
- ❖ Ensure there are no leaks from the pump
- ❖ Ensure functionality of the auxiliary systems

The following has to be checked at regular intervals:

- ❖ Temperature of the bearing support (Alarm: 230°F, switching off: 250°F)
- ❖ No change of operating conditions
- ❖ No change of noise level
- ❖ Condition and level of barrier medium

## 7.2 Inspection and Maintenance Table

<b>Inspection Interval</b>	<b>Subassembly</b>	<b>Maintenance Activity</b>
Hourly during the start-up phase	Barrier pressure System	Check barrier medium level, adjust if necessary
Daily	Barrier Pressure System	Check barrier medium level, adjust if necessary
Daily	Gear Casing	Check gear oil level, top up if necessary
Daily	Mechanical Seal	Check for leaks, if leaks are present, contact the manufacturer and replace if necessary.
Daily	Shaft Seal Rings	Check for leaks, if leaks are present, contact the manufacturer and replace if necessary.
Daily	System	Check function, top off if necessary. If contamination is present, check mechanical seal and replace barrier/quench fluid
Daily	System	Check function and freedom from leaks
Weekly	Drive unit	Check for wear in accordance with manufacturer's instructions
Initially after 300 operating hours or 3 months	Gear casing	Change gear oil
With non-continuous operation, every 2000 hours or after 3 months	Gear casing	Change gear oil
With continuous operation, every 3000 operating hours	Gear casing	Change gear oil
6 months	Pressure System	Change barrier medium

### 7.2.1 Changing the lube oil

- ❖ Undo drain screw on the gear casing and drain lube oil at warm operating temperature
- ❖ Refit drain screw with new seal
- ❖ Undo locking screw on bearing casing and venting screw on gear casing and top up with lube oil until the oil level reaches the middle of the oil level eye
- ❖ Refit locking screw on bearing casing and venting screw on gear casing.

The following gear oils are suitable for foodstuff and pharmacy products:

Gear oil with NSF or USDA HI certification

Synthetic oil with polyalpholefin, not mixable with mineral oils

#### CAUTION

Risk of damage to equipment is possible if non-compatible lubricants are used!

Only use one type of lubricant. Do not mix lubricants.

### 7.2.2 Lubricant table

Manufacturer	Gear oil
Aral/Castrol/Opti	Optileb GT100
Lubriplate	SFGO Ultra 100
Fuchs/DEA	Geralyn SF100/Cassida HF 100
Klüber	Klüberoil 4 UH1-100N
Mobil	MOBIL DTE FM100

### 7.3 Cleaning/Sterilizing

#### 7.3.1 CIP cleaning at CIP temperature < 180 °F

- ❖ The pump is switched off
- ❖ In the case of pumps with barrier system: barrier system in operation

- ❖ Switch piping system to CIP medium
- ❖ Start pump
- ❖ Clean piping system and pump
- ❖ Switch off pump
- ❖ Remove CIP medium, ensure no residues are left
- ❖ If necessary, flush and neutralize system

**7.3.2 CIP cleaning/sterilizing at CIP temperature > 180 °F with barrier system or quench system**

- ❖ The pump is switched off
- ❖ Start barrier/quench system
- ❖ Warm up pump when at standstill
- ❖ Switch piping system to CIP medium
- ❖ Wait till casing temperature > 140 °F
- ❖ Start the pump
- ❖ Clean piping system and pump
- ❖ Switch off pump
- ❖ Remove CIP medium, ensure no residues are left
- ❖ If necessary, flush and neutralize system

**7.3.3 CIP cleaning/sterilizing at CIP temperature > 180 °F without barrier system or quench system**

- ❖ The pump is switched off
- ❖ Only clean/sterilize pump when at standstill
- ❖ Cleaning duration < 30 minutes
- ❖ When cleaning/sterilizing using steam, block the pump as a turbine effect can occur
- ❖ Switch piping system to CIP medium



- ❖ Clean piping system and pump
- ❖ Remove CIP medium, ensure no residues are left
- ❖ Undo block
- ❖ If necessary, flush and neutralize system

#### **7.3.4 Mechanical cleaning/sterilizing**

- ❖ Switch off pump and make sure it cannot be switched on again
- ❖ Close intake and discharge-side valves
- ❖ Switch off heating/cooling system if present, make sure it cannot be switched on again
- ❖ Switch off auxiliary operating systems if present, make sure they cannot be switched on again
- ❖ Depressurize pump and auxiliary operating systems
- ❖ Undo intake and discharge lines from pump casing
- ❖ Remove pump casing
- ❖ Undo fixing bolts
- ❖ Remove form sealing rings from the intermediate flange and cover
- ❖ Clean/sterilize pump casing and pump internals with suitable cleaning agent
- ❖ Fit form sealing rings
- ❖ Tighten fixing bolts
- ❖ Slide pump casing over the screws and tighten down cover.

## 8. Malfunctions / Causes / Rectification

No delivery volume	Delivery volume too low	Delivery volume too large	No pump suction	Not running smoothly	Pump will not rotate	Pump has leak	Power input for motor too high	Non-permitted temperature increase	Cause	Rectification
x	x			x			x	x	Pressure difference too great	Modify operating data
x	x		x					x	Clearance between pumping elements and casing too great	Replace worn parts
x			x						Incorrect direction of rotation	Change direction of rotation
x	x		x					x	Speed too low	Increase speed
x	x		x	x					Feed line closed	Open feed line (valve)
x	x		x						Air is sucked in	Seal intake Increase speed
x	x		x	x					Pump cavitation: $NPSH_r < NPSH_a$	Improve feed line Reduce speed
x			x	x			x	x	Pressure line closed	Open pressure line
x			x		x		x		Pump blocked by solid matter	Clean pump Coordinate with manufacturer
x	x	x	x	x			x	x	Operating conditions deviate from datasheet	Coordinate with manufacturer
		x		x			x	x	Speed too high	Reduce speed
x	x		x			x			Shaft seal defective	Replace shaft seal
x			x						Pump not filled before start	Fill pump
				x					Oil level in gear casing too low	Correct oil level
			x			x			Casing moulded ring defective	Replace moulded ring
				x	x		x		Piping and pump twisted	Optimize piping
				x	x		x		Pumping elements dirty	Clean pumping elements
				x	x				Coupling not aligned	Align coupling
				x	x		x		Thermal expansion of pumping elements because of rapid temperature fluctuations	Wait for temperature equalization
					x		x		Roller bearings defective	Replace roller bearings

## **9. Servicing, Spare Parts, Accessories**

Spare parts not supplied by the manufacturer directly or through distribution are not approved. The use of such parts can change the characteristics of the pump and will void any warranty.

No liability or warranty claims shall be accepted for any damage arising from the use of non-original spare parts and accessories. The service department of the manufacturer may only rectify malfunctions that cannot be rectified by the user.

Spare parts can be ordered either through distribution or directly. The supplied drawings are designed only for the identification of spare parts and spare part procurement. They must not be used as installation instructions.

**Appendix**

This certificate must be filled out and sent with any repair in order to ensure that the pump is dealt with correctly.

**Compliance Certificate**

The pump and its accessories sent for repair/inspection together with this compliance certificate:

Type: .....

Serial no.: .....

Reason for request for inspection/repair: .....

- has not been used for / in fluids that are dangerous to health
- was used for .....and came into contact with fluids subject to mandatory labeling or were contaminated with harmful substances.

Please state last pumping medium:.....

The pump was carefully emptied before shipping / dispatch and has been cleaned inside and outside using the following cleaning agent .....

- No special safety precautions are necessary for subsequent handling.
- The following safety precautions with regard to rinsing liquids, residual fluids and disposal are required:

We assure that the above statements are correct and complete and that the pump is being shipped in accordance with statutory regulations.

Company:

Department/contact person:

Tel:

Fax:

Address:

Street:

Town/postcode:

**Declaration of Conformity**

**In terms of CE Machine's Directive 2006/42/EG, Appendix II A**

Company: Jung Process Systems GmbH  
Auweg 2  
25495 Kummerfeld  
Germany

Pump Series: HYGHSPIN (AXIFLOW)

We herewith declare that the pump delivered with already assembled electrical drive motor corresponds to the following relevant regulations:

CE Machine's Directive 2006/42/EG

CE Low Voltage Directive 73/23/EWG

The following harmonized norms have been applied:

EN 12100 Safety of Machines

EN 60204 Electrical Equipment of Machines

This declaration expires in case modifications of the pump unit have been effected without our prior acceptance.



(Signature)

**Declaration of Incorporation**

**In terms of CE Machine's Directive 2006/42/EG, Appendix II B**

Company: Jung Process Systems GmbH  
Auweg 2  
25495 Kummerfeld  
Germany

Pump Series: HYGHSPIN (AXIFLOW)

We herewith declare that the pump delivered without drive motor is dedicated for assembly into a machine or for assembly to a complete unit with other machines.

The commissioning of this pump is prohibited until that date when it has been confirmed that the machine - into this pump was integrated – corresponds to the regulations of the CE Directive 2006/42/EG.

This declaration expires in case modifications of the pump have been effected without our prior acceptance.

*Wolke Christa*

(Signature)

# Disassembly & Assembly Instructions

## AXIFLOW

### Twin Screw Pump



**AXIFLOW**   
**TECHNOLOGIES, INC.**

**Axiflow Technologies Inc.**

P.O. Box 17150  
Tampa, Florida 33682

Tel.: 1-800-AXIFLOW (294-3569)

Fax: 1-877-569-0775

[www.axiflowtechnologies.com](http://www.axiflowtechnologies.com)



## Contents

Contents .....	2
1 General information .....	3
2 Removal of the pump from the unit .....	3
3 Disassembling the feed screws and mechanical seals .....	3
4 Assembling the feed screws and mechanical seals.....	4
5 Removing the bearing support .....	6
6 Assembling bearing support.....	7
Appendix A .....	10



## **1. General information**

These instructions are designed to be used in conjunction with the sectional drawing.

For reasons of economy and operational safety the following parts should not be reused:

- ❖ Flat gaskets (item 128)
- ❖ O-rings (at the mechanical seal)
- ❖ Shaped rings (items 103, 126 and the mechanical seal)
- ❖ Radial shaft seals (items 106, 117)
- ❖ Locking washers (item 109)
- ❖ Locking plate (item 119)
- ❖ Spring washers (items 113 and 114)

The materials and product compatibility of all ancillary products used (lubricants, cleaning agents, adhesives and securing devices) must be checked before use.

## **2. Removal of the pump from the unit**

Switch off unit and make sure it cannot be switched on again.

**Important: Make sure you read the Safety Section in the Operating Instructions!**

- ❖ Remove piping on the discharge and intake sides
- ❖ Remove the coupling protection
- ❖ Undo the pump-side coupling half from the drive shaft and pull the coupling apart
- ❖ Fix pump to crane with eye bolt or secure with crane harness
- ❖ Undo pump foot from base plate. Caution – risk of tipping over!
- ❖ Lift pump and put down on a suitable surface
- ❖ Remove lifting gear.

## **3. Disassembling the feed screws and mechanical seals**

- ❖ Remove cap nuts (item 100) and cover (item 1) and pump casing (item 2)

- ❖ Remove casing shaped rings (item 103)
- ❖ Block feed screws with the aid of a piece of soft metal (copper, aluminum etc.)

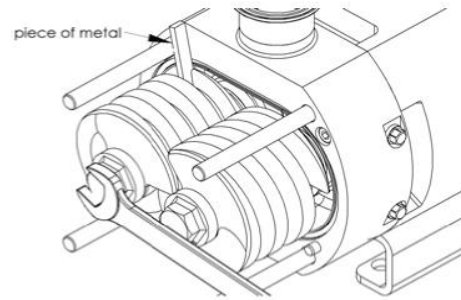
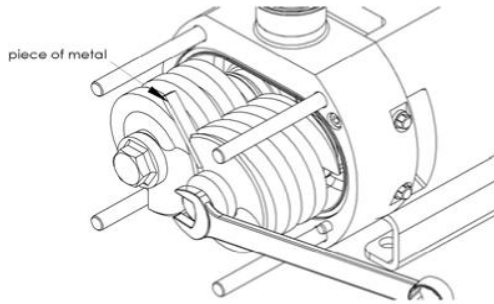

- ❖ Undo clamping nuts (item 18) by turning counter-clockwise
- ❖ Remove bottom stud bolts (item 9)
- ❖ Remove pair of feed screws (item 6)
- ❖ Upon removal of feed screws, inspect clamping nuts, stud bolts and shafts for the presence of the soil and/or product residue. See Appendix A, Item 2 for the cleaning procedure.
- ❖ Remove rotating units of the mechanical seals
- ❖ Remove socket head bolts (item 102)
- ❖ Remove intermediate flange (item 3)
- ❖ Remove top stud bolts (item 9)
- ❖ In the case of double-acting mechanical seals (item 104), remove seal rings from the shafts
- ❖ Remove socket-head bolts for mechanical seals at the intermediate flange (item 3)
- ❖ Remove mechanical seals (item 104) from the intermediate flange (item 3). If necessary, use set/jacking screws

#### **4. Assembling the feed screws and mechanical seals**

**For tightening torques, see table (page 10).**

- ❖ Check sliding surfaces of the mechanical seals for score marks and cracks
- ❖ Insert mechanical seals (item 104) in the intermediate flange (item 3)
- ❖ Screw mechanical seal Housings to intermediate flange (item 3) with socket-head bolts

- ❖ In the case of double-acting mechanical seals (item 104), mount rotating seal rings on the shafts
- ❖ Screw in 2 stud bolts (item 9) for guidance of the intermediate flange (do not insert completely)
- ❖ Fit casing shaped ring (item 103)
- ❖ Mount intermediate flange (item 3)
- ❖ Remove stud bolts again (item 9)
- ❖ Mount rotating units of the mechanical seals
- ❖ Position feed screws on a level surface so that they intermesh and rotate them against each other until both faces lie completely even on the surface

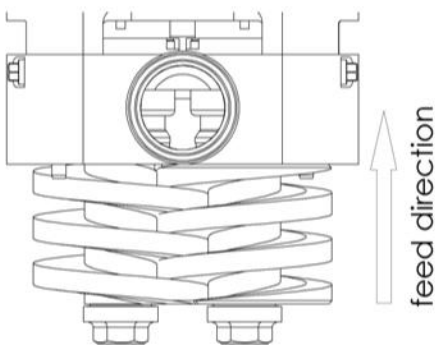

Type NR

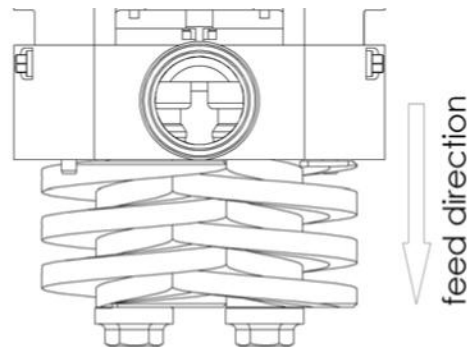

Type SR

Feed screws with rightward rotation with mechanical seal on the discharge side, "VS" on bottom of the pump casing

Feed screws with rightward rotation with mechanical seal on the intake side, "VS" on bottom of the pump casing

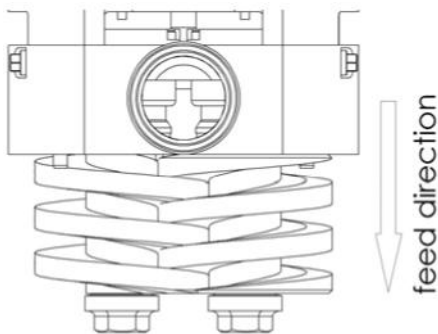

Type SL

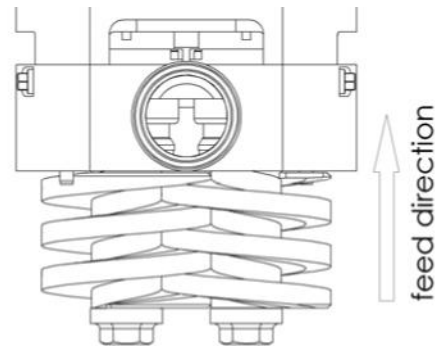

Type NL (Standard)

Feed screws with leftward rotation with mechanical seal on the intake side, "VS" on top of the pump casing

Feed screws with leftward rotation with mechanical seal on the discharge side, "VS" on top of the pump casing

**Important: All rotation references are as if you are facing the shaft end of the pump.**

**Important: The feed screws must not be swapped, as this will change the direction of the feed.**

- ❖ Block feed screws with the aid of a piece of soft metal (copper, aluminum etc.)
- ❖ Tighten feed screws (item 6) with clamping nuts
- ❖ Screw in stud bolts (item 9) (do not insert completely)
- ❖ Mount pump casing (item 2). When the main direction of rotation is rightward, the "VS" stamped on the face must point down towards the cover (clockwise when looking towards the end of the drive shaft)
- ❖ Mount pump casing (item 2)
- ❖ Insert casing shaped ring (item 103) in cover
- ❖ Mount cover (item 1)
- ❖ Screw on and tighten capped nuts (item 100) with washers (item 101)

## **5. Removing the bearing support**

- ❖ Remove product-contact parts
- ❖ Drain gear oil using the oil drain screw (item 19)
- ❖ Unscrew socket head bolts (item 122)
- ❖ Remove gear hood (item 5), flat gasket (item 128) and shaft seal (item 117)
- ❖ Block gearwheels (items 11 and 13) with the aid of a piece of soft metal (copper, aluminum etc.)

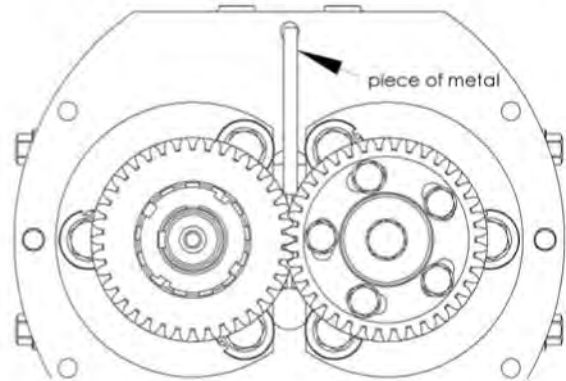
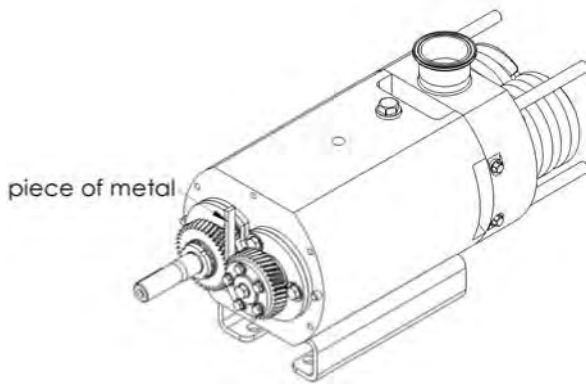

- ❖ Undo hexagonal bolts (item 12) and remove together with washers (item 111)
- ❖ Undo hexagonal bolt (item 115)
- ❖ Remove gearwheels (items 11 and 13) together with spring washer (item 114) and clamping sleeve (item 10)
- ❖ Remove bearing covers (items 14 and 15) with Nilos ring (item 121)
- ❖ Remove spacer sleeves (item 16)
- ❖ Pull shafts (items 7 and 8) out of the bearing casing
- ❖ Remove front securing V ring (item 125)
- ❖ Move spacer sleeve (item 17)
- ❖ Remove angular contact ball bearings (item 107) with the aid of an extractor
- ❖ Remove spacer sleeves (item 17)
- ❖ Remove rear securing V ring (item 125)
- ❖ Remove needle bearings (item 123) and bearing internal ring (item 124)
- ❖ Remove shaft seal rings (item 106)

## 6. Assembling bearing support

- ❖ Mount one securing V ring (item 125) on each shaft (items 7 and 8)
- ❖ Warm bearings before assembly to 195°F with the aid of a suitable device

**Important: The bearing temperature must NOT exceed 250°F, even partially!**

- ❖ Pull bearing inner ring (item 124) and needle bearings (item 123) onto shafts (items 7 and 8)
- ❖ Mount rear securing V rings (item 125) onto shafts (items 7 and 8)
- ❖ Mount spacer sleeves (item 17) with larger diameter on the needle bearings
- ❖ Mount angular contact ball bearings (item 107) on the shafts

**Important: Make sure the installation position is correct!**

Mechanical seal on the discharge side

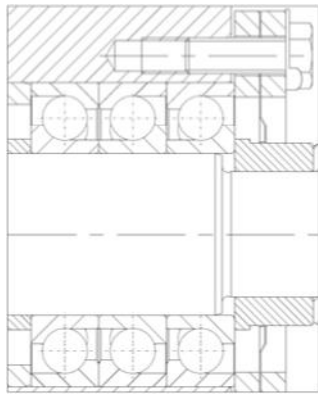

Mechanical seal on the intake side

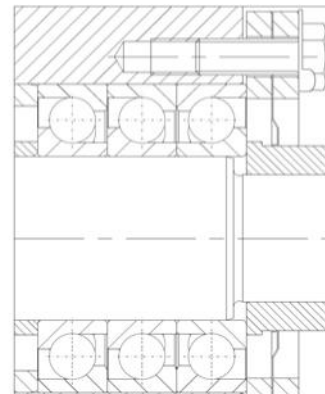

- ❖ Push shafts (items 7 and 8) into the bearing casing. The lubrication holes of the needle bearings should be aligned upwards
- ❖ Mount spacer sleeves (item 16)
- ❖ Mount bearing cover with groove downward (item 14)
- ❖ Mount Nilos ring (item 121) and bearing cover (item 15)
- ❖ Mount locking washers (item 109) with hexagonal bolts (item 110)
- ❖ Tighten hexagonal bolts (item 110) in accordance with tightening torque table
- ❖ Rotate shafts and check that there is no sound of grinding/friction between Nilos rings (item 121) and spacer sleeves (item 16). Adjust if necessary
- ❖ Mount gearwheel on drive side (item 13) with locking plate (item 119)
- ❖ Mount driven gearwheel (item 11) with clamping sleeve (item 10) and spring washer (item 114)

- ❖ Mount hexagonal bolts (item 112) with washers (item 111) and spring washer (113). The hexagonal bolts (item 112) should be centrally positioned in the elongated holes of the gearwheel (item 11)
- ❖ Tighten slotted nut (item 118) and hexagonal bolt (item 115), secure with locking plate (item 119)
- ❖ Undo hexagonal bolts (item 112) again
- ❖ Mount product-contact part of the pump in accordance with instructions "Mounting the feed screws and mechanical seals"
- ❖ Set the clearance between the feed screws (item 6) with the aid of the elongated holes in the gearwheel (item 11). If the elongated holes are not sufficient, undo the hexagonal bolt (item 115) and the gearwheel (item 11) in order to move it along by one or more teeth
- ❖ Block gearwheels (items 11 and 13) again with the aid of a piece of soft metal (copper, aluminum etc.) and tighten hexagonal bolts (item 112) in accordance with the tightening torque table

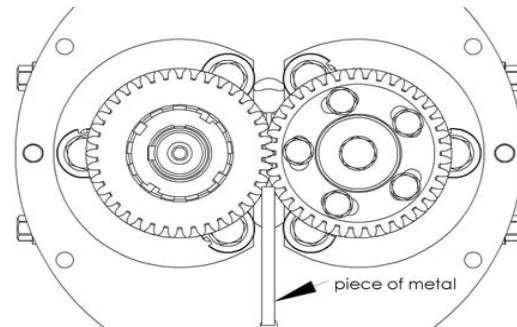
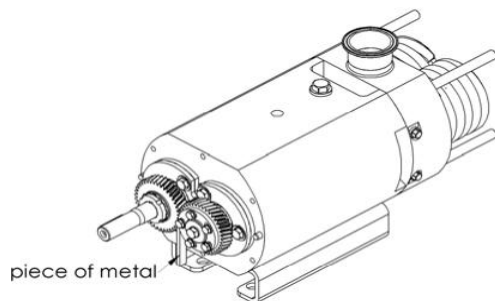

- ❖ Press shaft seal rings (item 106) into bearing casing (item 4). Use the manufacturer's assembly tools for this
- ❖ Press shaft seal ring (item 117) into gear casing
- ❖ Mount gear hood (item 5) with flat gasket (item 128)
- ❖ Screw in socket head bolts (item 102)
- ❖ Press shaft seal ring (item 117) into gear hood (item 5)
- ❖ Drive the key (item 116) into the drive shaft

- ❖ Screw in oil drain screw (item 19) and fill with gear oil via the locking screw up to the oil level indicator marking
- ❖ Finish assembling the product-contact part of the pump in accordance with instructions for "Mounting the feed screws and mechanical seals".

## Appendix A

### 1. Torque Tightening Table

Designation	Item no.	STSC 50	STS (C) 70	STS (C) 90	STS 125
Clamping nut	18	11 Ft-lbs.	20 Ft-lbs.	82 Ft-lbs. (M16)	148 Ft-lbs.
Capnut	100	20 Ft-lbs.	37 Ft-lbs.	82 Ft-lbs. (M16)	148 Ft-lbs.
Hexagonal bolt	110	9 Ft-lbs.	20 Ft-lbs.	40 Ft-lbs. (M10)	40 Ft-lbs. (M10)
Hexagonal bolt	112	6 Ft-lbs.	9 Ft-lbs.	20 Ft-lbs. (M8)	40 Ft-lbs. (M10)
Hexagonal bolt	115	12 Ft-lbs.	12 Ft-lbs.	45 Ft-lbs. (M12)	310 Ft-lbs.

### 2. Non-Product Contact Cleaning Procedure

- a. Visually inspect all internal, external threads and enclosed non-product contact cavities.
- b. Clean all threads (internal and external) with a capable soft bristle brush and an approved and suitable cleaner.
- c. Verify all residue has been removed. Reclean as necessary.
- d. Sanitize all surfaces with approved and suitable sanitizer.
- e. Keep all sanitized parts and surfaces protected from contamination prior to reassembly.





**AXIFLOW**   
**TECHNOLOGIES, INC.**

**This Page is Left Blank Intentionally**