

Instruction Manual

Unique SSV Tangential body/Tank Valve

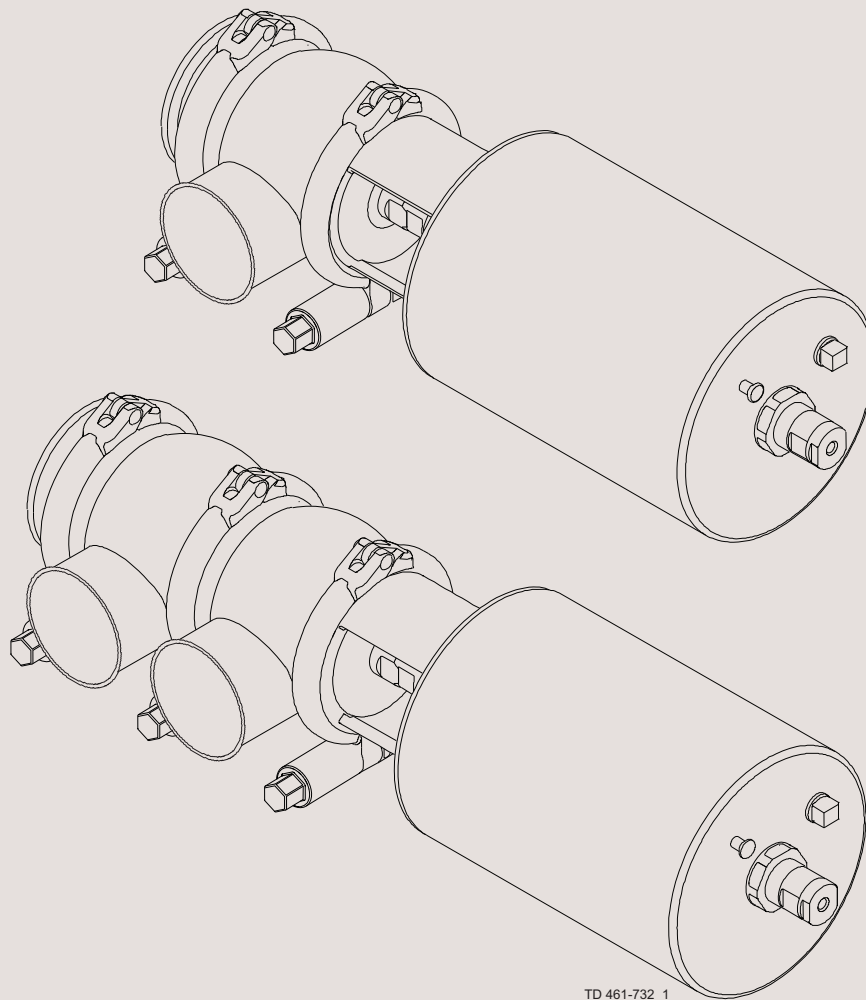

TD 461-732_1

ESE00586-ENUS6 2019-03

Original manual



CSI

CONTACT CSI FOR MORE INFORMATION | CSIDESIGNS.COM | SALES@CSIDESIGNS.COM | 417.831.1411

Table of contents

The information herein is correct at the time of issue but may be subject to change without prior notice

1. EC Declaration of Conformity	4
2. Safety	5
2.1. Important information	5
2.2. Warning signs	6
2.3. Safety precautions	7
3. Installation	9
3.1. Unpacking/delivery	9
3.2. General installation	10
3.3. Welding	13
3.4. Recycling information	14
4. Operation	15
4.1. Operation	15
4.2. Troubleshooting	17
4.3. Recommended cleaning	18
5. Maintenance	20
5.1. General maintenance	20
5.2. Dismantling of valve	22
5.3. Seat ring replacement	23
5.4. Valve assembly	25
5.5. Actuator types	26
5.6. Actuator bushing replacement (non-maintainable actuator)	27
5.7. Dismantling of fully maintainable actuator (removable yoke with bolts/2006-June 2016) ..	32
5.8. Dismantling of fully maintainable actuator (yoke without bolts/June 2016 ->)	33
5.9. Mounting of fully maintainable actuator	34
5.10. Changing pneumatic movement on fully maintainable actuator (NC/NO)	35
6. Technical data	36
6.1. Technical data	36
7. Parts list and Service Kits	37
7.1. Unique SSV - Tangential body/Tank Valve	37
7.2. Unique SSV Tangential body/Tank Valve - Shut-off-Valve 2"-4"	40
7.3. Unique SSV Tangential body/Tank Valve - Change-over Valve 2"-4"	42
7.4. Unique SSV maintainable actuator	44



1 EC Declaration of Conformity

Revision of Declaration of Conformity 2013-02-03

The Designated Company

Alfa Laval Kolding A/S
Company Name

Albuen 31, DK-6000 Kolding, Denmark
Address

+45 79 32 22 00
Phone No.

hereby declares that

Valve
Designation

Unique SSV PN10
Type

From serial number 1000000 to 70000000000

is in conformity with the following directive with amendments:

- Machinery Directive 2006/42/EC
- Pressure Equipment Directive 2014/68/EU category 1 and subjected to assessment procedure Module A. May only be used for fluids in Group 2

The person authorised to compile the technical file is the signer of this document

Global Product Quality Manager
Pumps, Valves, Fittings and Tank Equipment
Title

Lars Kruse Andersen

Name

Kolding
Place

2016-06-01
Date



Signature



Unsafe practices and other important information are emphasized in this manual.
Warnings are emphasized by means of special signs.

2.1 Important information

Always read the manual before using the valve!

WARNING

Indicates that special procedures must be followed to avoid serious personal injury.

CAUTION

Indicates that special procedures must be followed to avoid damage to the valve.

NOTE



Indicates important information to simplify or clarify procedures.

Different actuator types for the SSV valve

In June 2016 the below change was implemented and the “removable yoke with bolts” version is thereby phased out and replaced by the “yoke without bolts” version.

NOTE

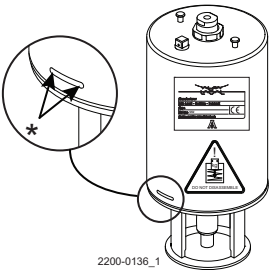
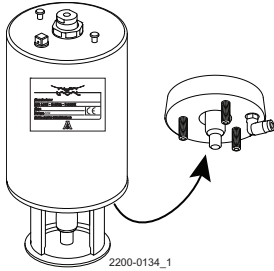
It is important to check for warnings marked on the actuator when servicing an actuator - see below table.

Actuator type	Non-maintainable actuator spring under load and CANNOT be opened	Fully maintainable actuator spring cage and can be opened	Fully maintainable actuator spring cage and can be opened
	 <p>2200-0136_1</p> <p>*) Lock wire opening is locked - when warning is marked on actuator</p>	 <p>2200-0134_1</p>	 <p>2200-0135_1</p>
Yoke type	Non-removable yoke	Removable yoke with bolts. If the yoke with bolts is damaged it has to be replaced by the “yoke without bolts”	Yoke without bolts
Service	Not possible to service internally (it is not possible to change piston O-rings)	Yes	Yes
Marked with warnings	Yes	No	No
Year of production	From 2006	From 2006 to June 2016	From June 2016

2 Safety

*Unsafe practices and other important information are emphasized in this manual.
Warnings are emphasized by means of special signs.*

2.2 Warning signs

General warning



Caustic agents



Danger of injury (lasermarked on the actuator)
Do **NOT** attempt to disassemble the actuator due to
spring under load danger!
(The lock wire opening is locked)



Danger of injury (an extra yellow label marked on the actuator
from June 2016)
Do **NOT** attempt to cut the actuator open due to
spring under load.
(The lock wire opening is locked).

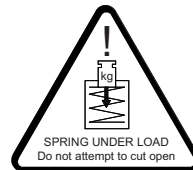

Danger of injury (label marked on actuator)
Do **NOT** attempt to cut the actuator open due to
spring under load
(The lock wire opening is locked)



All warnings in the manual are summarized on this page.

Pay special attention to the instructions below so that severe personal injury and/or damage to the valve are avoided.

2.3 Safety precautions

Actuators

If support air is utilised:



- Shock in the actuator must **NEVER** occur
- Support air on high pressure actuator versions is **NOT** allowed

To prevent shock in the actuator and to prevent exceeding 145 PSI (10 bar) product pressure, Alfa Laval recommends **NOT** to exceed 43.5 PSI (3 bar) support air on the spring side in all the Unique SSV actuators.

If support air is connected always use the 43 PSI (3 bar) air relief fittings = 9611996094 (1/4" = 6,35 mm hose)

Using the 43.5 PSI (3 bar) air relief fitting also extends the service life of the actuator piston o-ring.

Obs. if using a 6 mm hose then use air relief fittings = 9611995903

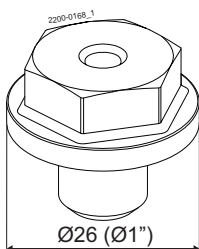

Pos. no. 5

For actuators, manufactured year 2005-2018, with serial number from 1000000 - 5999999 and from 20000000000 - 59999999999 always use steel adapter (pos 5) = 9614065301

Tighten torque = 23 lbf-ft (30 Nm)

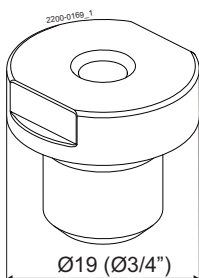

Pos. no. 5

For actuators, manufactured year 2019 --> with serial number from 6000000 to 7000000 and from 60000000000 to 70000000000 always use steel adapter (pos 5) = 9615374701

Tighten torque = 11 lbf-ft (15 Nm)

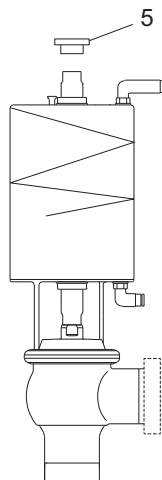

Alfa Laval recommends max. 43,5 PSI (3 bar) support air

Always use the 43,5 PSI (3 bar) air relief fittings" on support air.

Alfa Laval article number = 9611996094 (1/4" = 6,35 mm hose)

TD 461-990_2



CSI

CONTACT CSI FOR MORE INFORMATION | CSIDESIGNS.COM | SALES@CSIDESIGNS.COM | 417.831.1411

2 Safety

All warnings in the manual are summarized on this page.

Pay special attention to the instructions below so that severe personal injury and/or damage to the valve are avoided.

Installation

Always read the technical data thoroughly (see section 6 Technical data)

Always release compressed air after use

Never touch moving parts if the actuator is supplied with compressed air

Never touch the valve or the pipelines when processing hot liquids or when sterilising

Never dismantle the valve with valve and pipelines under pressure

Never dismantle the valve when it is hot

Never cut the actuator open, due to spring under load

- if marked with this warning



AND



Do **NOT** attempt to disassemble the actuator due to spring under load danger !

Operation

Never dismantle the valve with valve and pipelines under pressure

Never dismantle the valve when it is hot

Always read the technical data thoroughly (see section 6 Technical data)

Always release compressed air after use

Never touch the valve or the pipelines when processing hot liquids or when sterilising

Never touch moving parts if the actuator is supplied with compressed air

Always rinse well with clean water after cleaning

Always handle lye and acid with great care



Maintenance

Always read the technical data thoroughly (see section 6 Technical data)

Always release compressed air after use

Never service the valve when it is hot

Never service the valve with valve and pipelines under pressure

Never stick your fingers through the valve ports if the actuator is supplied with compressed air

Never touch moving parts if the actuator is supplied with compressed air

Always use Alfa Laval genuine spare parts

Never cut the actuator open, due to spring under load danger

- if marked with this warning



AND



Do **NOT** attempt to disassemble the actuator due to spring under load danger !

Transportation

Always ensure that compressed air is released

Always ensure that all connections are disconnected before attempting to remove the valve from the installation

Always drain liquid out of valves before transportation

Always use predesigned lifting points if defined

Always ensure sufficient fixing of the valve during transportation - if specially designed packaging material is available, it must be used



CSI

CONTACT CSI FOR MORE INFORMATION | CSIDESIGNS.COM | SALES@CSIDESIGNS.COM | 417.831.1411

The instruction manual is part of the delivery. Study the instructions carefully.

The items refer to parts list and service kits section.

The valve is supplied as separate parts as standard (for welding).

The valve is assembled before delivery, if it is supplied with fittings.

3.1 Unpacking/delivery

Step 1

CAUTION

Alfa Laval cannot be held responsible for incorrect unpacking.

Check the delivery for:

1. Complete valve, shut-off valve (RA) or change-over valve (RA) (see steps 2a and 2b).
2. Delivery note.
3. Instruction manual.

Step 2

2a

Shut-off valve:

1. Complete actuator.
2. Bonnet (20).
3. 2 x clamp (19).
4. Valve plug (23).
5. Valve body (26).
6. Port seal element (63)

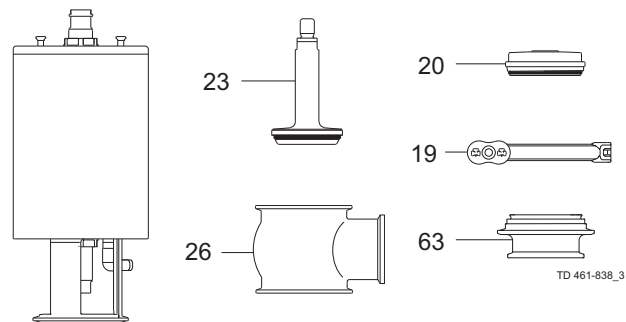

2b

Change-over valve:

1. Complete actuator.
2. Bonnet (20).
3. 3 x clamp (19).
4. Valve plug (27).
5. Valve seat (28).
6. 2 x upper valve body (26).
7. Port seal element (63).

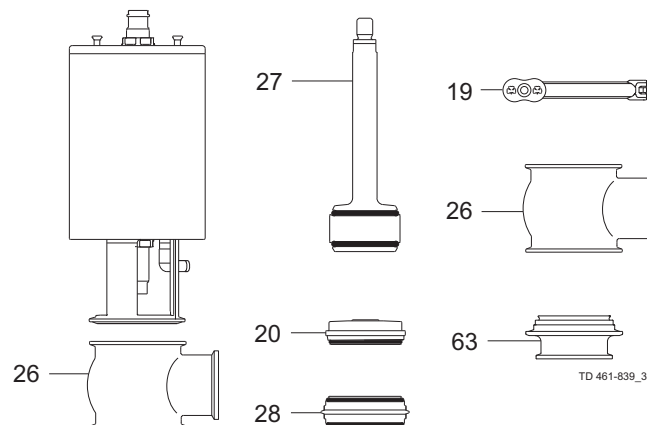

Step 3

Remove possible packing materials from the valve / valve parts.

Inspect the valve / valve parts for visible transport damages.

Avoid damaging the valve / valve parts.



3 Installation

Study the instructions carefully and pay special attention to the warnings!
The valve has welding ends as standard but can also be supplied with fittings.

3.2 General installation

Step 1



- CAUTION

- Alfa Laval cannot be held responsible for incorrect installation.
- **Always** release compressed air after use.
- **Always** read the technical data thoroughly.
See chapter 6 Technical data.



Do **NOT** attempt to disassemble the actuator due to spring under load danger.



AND



If marked with this warning, do **NOT** attempt to cut the actuator open, due to spring under load danger.

Step 2



Never touch moving parts if the actuator is supplied with compressed air.

Moving parts!

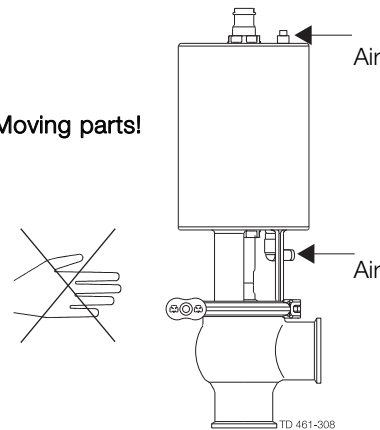

Step 3

To avoid water hammering, it is recommended to install the valve so that the flow is against the spring closing direction.

Shock in the actuator must **never** occur.

Avoid water hammering!

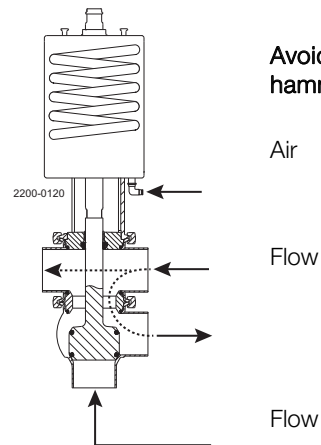

3 Installation

Study the instructions carefully and pay special attention to the warnings!
The valve has welding ends as standard but can also be supplied with fittings.

Step 4

If support air is utilized;
Pay special attention to shock in the actuator due to support air.
Shock in the actuator must **never** occur.

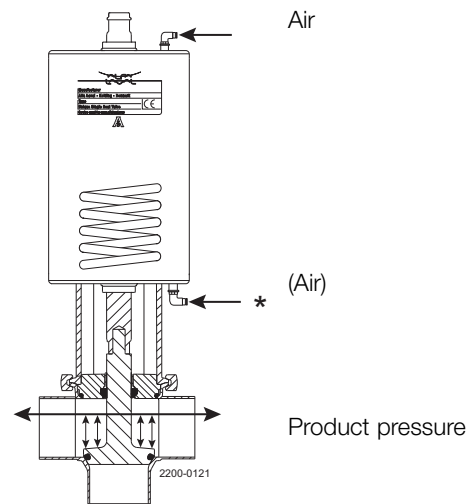

*) Careful if using support air on spring side and a high product pressure above the plug, as this can result in a high "hammer effect" which can damage the actuator.
Use Alfa Laval part no. 9611996094, which ensures max. 43,5 PSI (3 bar) support air pressure.
Alternatively remove the product pressure while activating the plug.

Step 5

Avoid stressing the valve.

Pay special attention to:

- Vibrations.
- Thermal expansion of the pipelines.
- Excessive welding.
- Overloading of the pipelines.

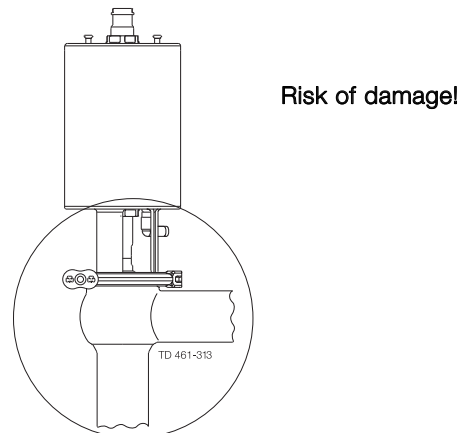

3 Installation

*Study the instructions carefully and pay special attention to the warnings!
The valve has welding ends as standard but can also be supplied with fittings.*

Step 6

Make sure that the leak detection hole in the valve body:

1. is visible, when mounting the valve vertically
2. always is downwards due to self-draining, when the valve is mounted horizontally.

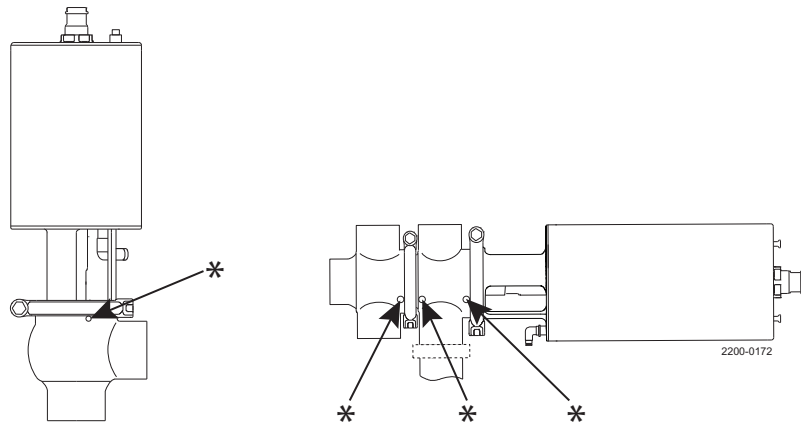

* = Leakage detection hole

3 Installation

Study the instructions carefully.
 The valve is supplied as separate parts to facilitate the welding.
 The items refer to the parts list and service kits section.
 Check the valve for smooth operation after welding.

3.3 Welding

Step 1

Always install valves with more than one valve body so that the seals between the valve bodies can be replaced. Do not weld more than one valve body into the system.

Valve size	A (inch)	B (inch)
1"	*	24.8
1 ½"	*	27.6
2"	*	29.5
2 ½"	*	29.1
3"	*	31.5
4"	*	31.1

* Depending on body combination and piping solution.

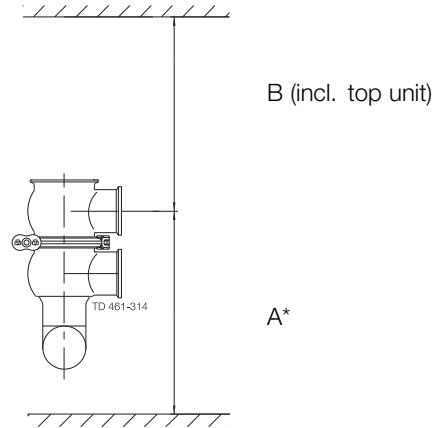

Step 2

Assemble the valve in accordance with the steps on page 24.

Pay special attention to the warnings!

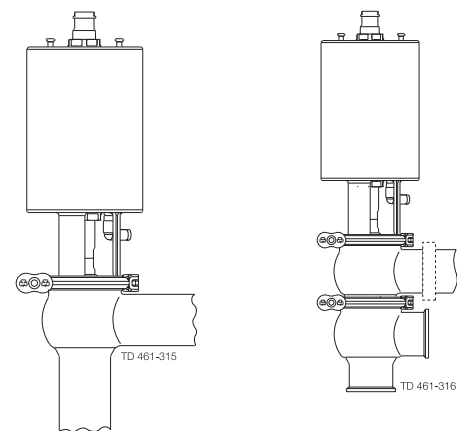

Step 3

Pre-use check:

1. Supply compressed air to the actuator.
2. Open and close the valve several times to ensure that it operates smoothly.

Pay special attention to the warnings!

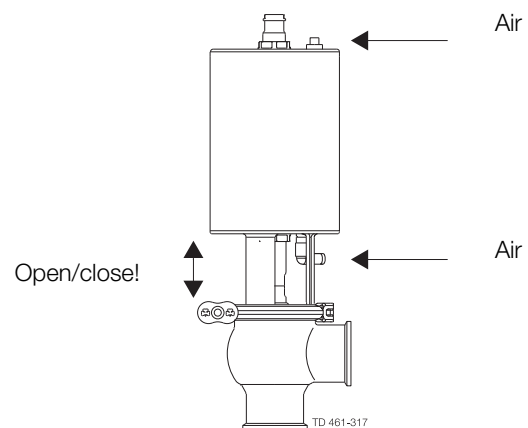

3 Installation

Study the instructions carefully.

The valve is supplied as separate parts to facilitate the welding.

The items refer to the parts list and service kits section.

Check the valve for smooth operation after welding.

3.4 Recycling information

- **Unpacking**

- Packing material consists of wood, plastics, cardboard boxes and in some cases metal straps
- Wood and cardboard boxes can be reused, recycled or used for energy recovery
- Plastics should be recycled or burnt at a licensed waste incineration plant
- Metal straps should be sent for material recycling

- **Maintenance**

- During maintenance oil and wear parts in the machine are replaced
- All metal parts should be sent for material recycling
- Worn out or defective electronic parts should be sent to a licensed handler for material recycling
- Oil and all non metal wearing parts must be taken care of in accordance with local regulations

- **Scrapping**

- At end of use, the equipment must be recycled in accordance with the relevant, local regulations. Besides the equipment itself, any hazardous residues from the process liquid must be considered and dealt with in a proper manner. When in doubt, or in the absence of local regulations, please contact your local Alfa Laval sales company. If the actuator is marked with a danger warning, do not attempt to cut the actuator open.



Do **NOT** attempt to disassemble the actuator due to spring under load danger!



If marked with this warning, do **NOT** attempt to cut the actuator open, due to spring under load danger.



If marked with this warning, do **NOT** attempt to cut the actuator open, due to spring under load danger.

Study the instructions carefully and pay special attention to the warnings!
 Ensure that the valve operates smoothly.
 The items refer to the parts list and service kits section.

4.1 Operation

Step 1



- CAUTION

- Alfa Laval cannot be held responsible for incorrect installation.
- **Always** release compressed air after use.
- **Always** read the technical data thoroughly.
See section 6 Technical data.
- **Always** use Alfa Laval genuine spare parts.
The warranty of Alfa Laval products is dependent on use of Alfa Laval genuine spare parts.



Do **NOT** attempt to disassemble the actuator due to spring under load danger.



AND



If marked with this warning, do **NOT** attempt to cut the actuator open, due to spring under load danger.

Step 2



Never touch the valve or the pipelines when processing hot liquids or when sterilising.

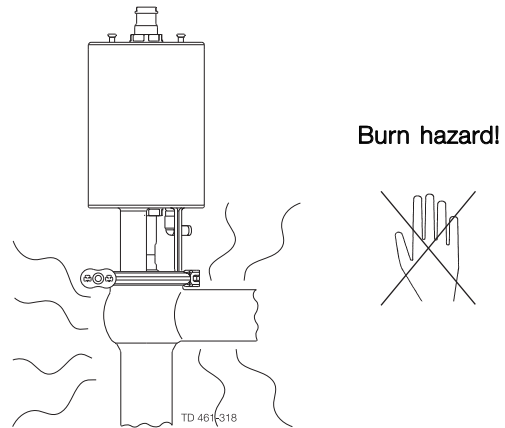

Step 3



Never touch moving parts if the actuator is supplied with compressed air.

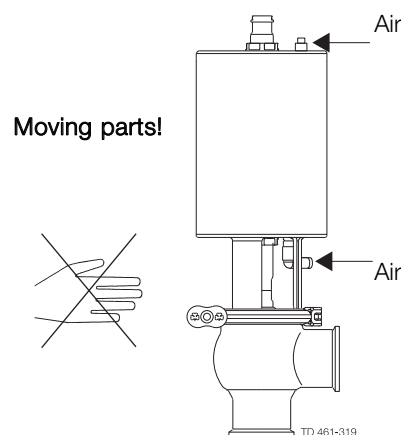

4 Operation

Study the instructions carefully and pay special attention to the warnings!

Ensure that the valve operates smoothly.

The items refer to the parts list and service kits section.

Step 4

Lubrication of valves:

1. Ensure smooth movement between lip seal (25) and plug stem (23, 27).
2. Lubricate the lip seal with Klüber Paraliq GTE 703 if necessary (see section 4.1).

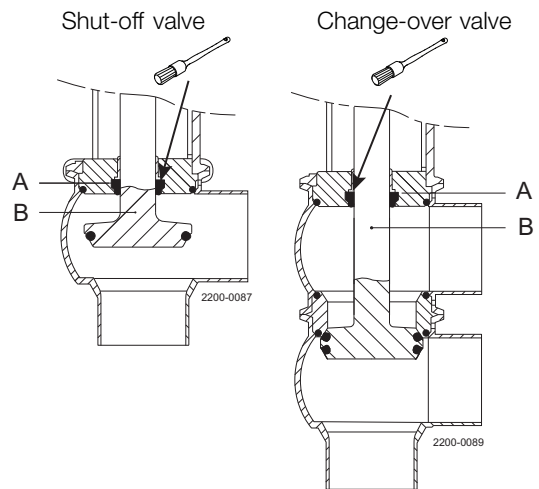

Step 5

Lubrication of actuator.

1. Ensure smooth movement of the actuator (the actuator is lubricated before delivery).
2. Lubricate all seals with Molykote Longterm 2 plus if necessary.

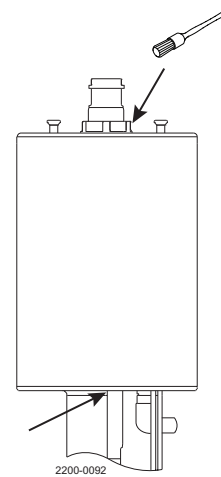

Pay attention to possible faults. Study the instructions carefully.
The items refer to the parts list and service kits section.

4.2 Troubleshooting

NOTE!

Study the maintenance instructions carefully before replacing worn parts. - See section 5.1 General maintenance

Problem	Cause/result	Repair
External product leakage	Worn or product affected lip seal and/or O-ring	<ul style="list-style-type: none"> - Replace the seals - Replace with seals of a different rubber grade
Internal product leakage	<ul style="list-style-type: none"> - Worn or product affected plug seal - Product deposits on the seat and/or plug - Product pressure exceeds actuator specification 	<ul style="list-style-type: none"> - Replace the seal - Replace with a seal of a different rubber grade - Frequent cleaning - Replace with a high pressure actuator - Use auxiliary air on the spring side (do not exceed 43.5 PSI (3 bar)) Alfa Laval article number = 9611996094 . See section and section , step 4. - Reduce product pressure
Water hammer	The flow direction is the same as the closing direction	<ul style="list-style-type: none"> - The flow direction should be against the closing direction - Throttle air release of solenoid in top unit
The valve does not open/close	Product pressure exceeds actuator specification	<ul style="list-style-type: none"> - Replace with a high pressure actuator - Reduce product pressure - Use auxiliary air on the spring side. Always use the pressure relief fittings 43.5 PSI (3 bar) on support side. Alfa Laval article number = 9611996094

If marked with a danger warning, do **NOT** attempt to cut the actuator open, due to spring under load.



Do **NOT** attempt to disassemble the actuator due to spring under load danger.



Do **NOT** attempt to cut the actuator open due to spring under load danger.



If marked with a danger warning, do **NOT** attempt to cut the actuator open, due to spring under load.

4 Operation

The valve is designed for cleaning in place (CIP). CIP = Cleaning In Place.
 Study the instructions carefully and pay special attention to the warnings!
 NaOH = Caustic Soda.
 HNO₃ = Nitric acid.

4.3 Recommended cleaning

Step 1



Always handle lye and acid with great care.

Caustic danger!



Always use rubber gloves!



Always use protective goggles!

Step 2



Never touch the valve or the pipelines when sterilising.

Burn hazard!

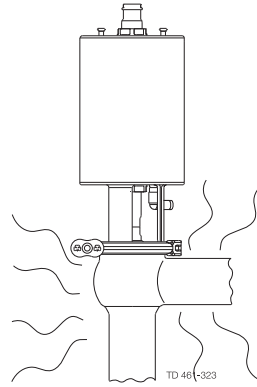

Step 3

Clean the plug and the seats correctly.
Pay special attention to the warnings.
Lift and lower valve plug momentarily!

Shut-off valve

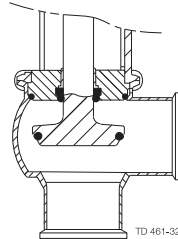

Change-over valve

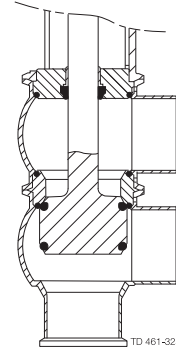

Step 4

Examples of cleaning agents:

Use clean water, free from chlorides.

- 1% by weight NaOH at 158° F

2.2 lb NaOH	+	26.4 gal water	=	Cleaning agent.
----------------	---	-------------------	---	-----------------

0.6 gal 33% NaOH	+	26.4 gal water	=	Cleaning agent.
---------------------	---	-------------------	---	-----------------

- 0.5% by weight HNO₃ at 158° F

0.2 gal 53% HNO ₃	+	26.4 gal water	=	Cleaning agent.
---------------------------------	---	-------------------	---	-----------------

The valve is designed for cleaning in place (CIP). CIP = Cleaning In Place.
Study the instructions carefully and pay special attention to the warnings!
NaOH = Caustic Soda.
HNO₃ = Nitric acid.

Step 5

1. Avoid excessive concentration of the cleaning agent.
2. Adjust the cleaning flow to the process.
3. **Always** rinse well with clean water after the cleaning.

NOTE

The cleaning agents must be stored/disposed of in accordance with current regulations/directives.

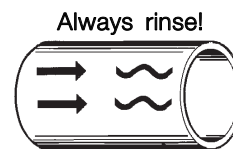

Clean water Cleaning agents

5 Maintenance

Service the valve regularly.

Study the instructions carefully and pay special attention to the warnings!

Always use Alfa Laval genuine spare parts. Always keep spare rubber seals and lip seals in stock.

Check the valve for smooth operation after servicing.

5.1 General maintenance

Step 1



- CAUTION

- Alfa Laval cannot be held responsible for incorrect installation.
- **Always** release compressed air after use.
- **Always** read the technical data thoroughly.
See section 6 Technical data.
- **Always** use Alfa Laval genuine spare parts.
The warranty of Alfa Laval products is dependent on use of Alfa Laval genuine spare parts.
- **NOTE**
All scrap must be stored/discharged in accordance with current rules/directives.



Do **NOT** attempt to disassemble the actuator due to spring under load danger.



AND



If marked with this warning, do **NOT** attempt to cut the actuator open, due to spring under load danger.

Step 2



Never service the valve when it is hot.

Never service the valve with valve and pipelines under pressure.

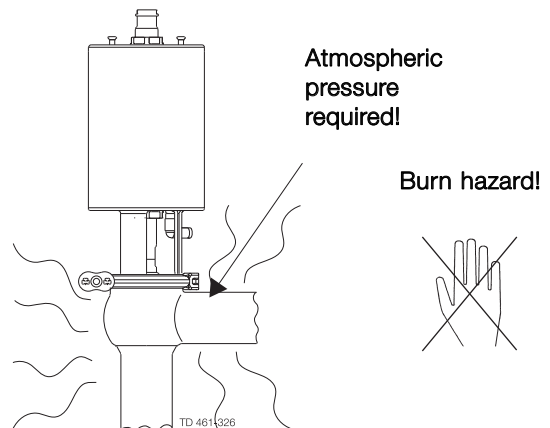

Step 3



Never stick your fingers through the valve ports if the actuator is supplied with compressed air.

Never touch the moving parts if the actuator is supplied with compressed air.

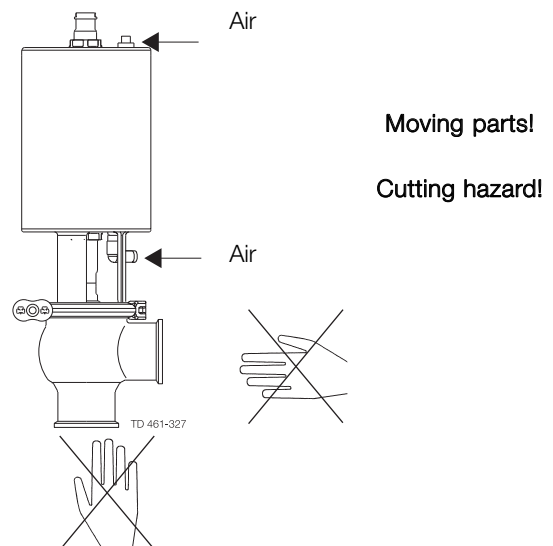

5 Maintenance

Service the valve regularly.

Study the instructions carefully and pay special attention to the warnings!

Always use Alfa Laval genuine spare parts. Always keep spare rubber seals and lip seals in stock.

Check the valve for smooth operation after servicing.

Below are some guidelines for maintenance and lubrication intervals. Please note that the guidelines are for normal working conditions in one shift.

	Product wetted seals	Actuator bushings complete
Preventive maintenance	Replace after 12 months depending on working conditions	Replace after 5 years depending on working conditions
Maintenance after leakage (leakage normally starts slowly)	Replace at the end of the day	Replace when possible
Planned maintenance	<ul style="list-style-type: none"> - Regular inspection for leakage and smooth operation - Keep a record of the valve - Use the statistics for planning of inspections Replace after leakage	<ul style="list-style-type: none"> - Regular inspection for leakage and smooth operation - Keep a record of the actuator - Use the statistics for planning of inspections Replace after leakage
Lubrication	Before fitting Klüber Paraliq GTE 703 or similar USDA H1 approved oil/grease	Before fitting Molykote Longterm 2 plus

Pre-use check:

1. Supply compressed air to the actuator.
2. Open and close the valve several times to ensure that it operates smoothly.

Pay special attention to the warnings!

Recommended spare parts

Service kits (see section 7 Parts list and Service Kits)

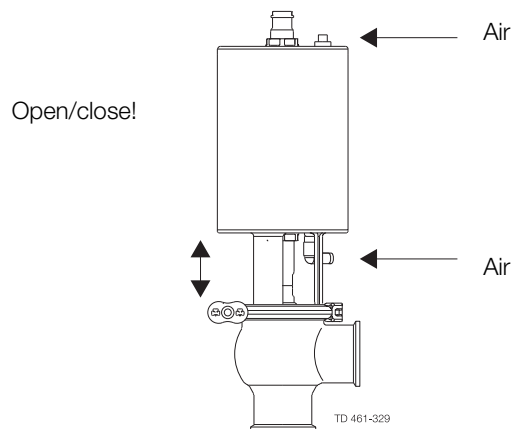

5 Maintenance

Study the instructions carefully. The items refer to the parts list and service kits section. Handle scrap correctly.

NC = Normally closed.

NO = Normally open.

A/A = Air/air activated.

5.2 Dismantling of valve

If the actuator is marked with a danger warning, do **NOT** attempt to cut the actuator open.



Do **NOT** attempt to disassemble the actuator due to spring under load danger.



Do **NOT** attempt to cut the actuator open due to spring under load danger.



Do **NOT** attempt to cut the actuator open due to spring under load danger.

Step 1

1a

Shut-off valve:

1. Supply compressed air to the actuator (only NC).
2. Loosen and remove upper clamp.
3. Release compressed air (only NC).
4. Lift away the actuator.
5. Unscrew and remove valve plug.
6. Remove O-ring, lip seal and bushing in bonnet. (Use bushing tool and rubber mallet).
7. Loosen and remove lower clamp.
8. Remove valve body.
9. Remove O-ring in port seal element.

Note! Be careful not to damage the bushing.

Pay special attention to the warnings!

Note! For plug seal replacement please see section 5.3 Seat ring replacement.

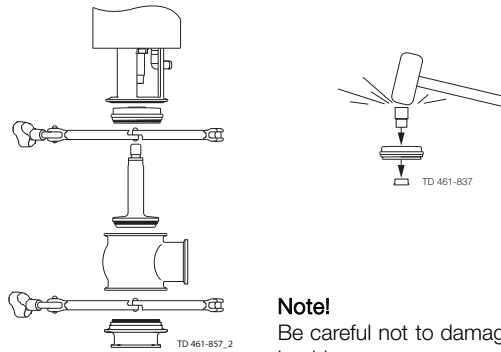

Note!

Be careful not to damage the bushing.

1b

Change-over valve:

1. Supply compressed air to the actuator (only NC).
2. Loosen and remove middle clamp.
3. Release compressed air (only NC).
4. Lift away the actuator and upper valve body.
5. Supply compressed air to the actuator (only NO).
6. Unscrew and remove valve plug.
7. Release compressed air (only NO).
8. Remove seat and O-rings.
9. Loosen and remove upper clamp.
10. Remove upper valve body.
11. Remove O-ring, lip seal and bushing in bonnet. (Use bushing tool and rubber mallet. See drawing, step 1a).
12. Loosen and remove lower clamp.
13. Remove valve body.
14. Remove O-ring in port seal element.

Note! Be careful not to damage the bushing.

Pay special attention to the warnings!

Note! For plug seal replacement please see section 5.3 Seat ring replacement.

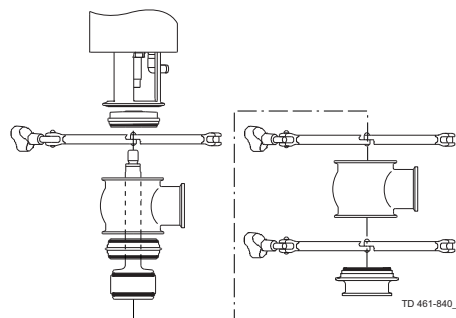

Study the instructions carefully. The items refer to the parts list and service kits section. Handle scrap correctly.

NC = Normally closed.

NO = Normally open.

A/A = Air/air activated.

5.3 Seat ring replacement

There are two plug seal ring options:

- A. Plug seal TR2
- B. Plug seal elastomer

A Plug seal TR2

1. Place the plug element on a firm support.
2. Using a utility knife, partially AND CAREFULLY cut through the upper ring portion of the TR2 plug avoiding contact with stainless steel stem.
3. Force apart both cut ends of the plug for removal from stem.
4. TR2 plugs are installed by applying uniform pressure on all sides. (Pressure can be applied by using the seat assembly tool.)
5. Using a piece of metal and a rubber mallet, place a precise tab to make the TR2 plug snap on to the stem. Reverse the tool and tab again to secure proper fit.
6. Examine seat assembly to be sure the TR2 plug is properly mounted, holding the seat assembly in one hand - rotate the TR2 plug. (For proper CIP cleaning the TR2 plug should turn freely on the stem.)

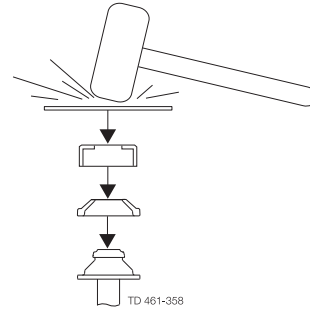

Use the mounting tool for TR2 - see spare part.

5 Maintenance

Study the instructions carefully. The items refer to the parts list and service kits section. Handle scrap correctly.

NC = Normally closed.

NO = Normally open.

A/A = Air/air activated.

B Plug seal elastomer

1. Remove old seal ring using a knife, screwdriver or similar.
Be careful not to damage the plug surface.
If using a screwdriver it must be placed underneath the plug groove (see drawing 1).
2. Grease the new seal ring with Paralique GTE 703, which is included in the service kit.
Only use a very small amount of grease.
3. Fit the seal ring on the plug without pressing it into the groove.
Be careful not to twist the seal ring.
Use a screwdriver (two turns) to fit the seal ring properly and to ensure it is not twisted (see drawing 2).
4. The seal ring can now be mounted by hand.
5. To ensure correct mounting press with your thumb on the seal ring which must be done approx. 10 times and always with opposite pressure points, from A and B, to C and D (see drawing 3).
The rest of the seal ring can now be pressed into the groove so all the seal ring is mounted. Check that there are NO "bulge" (see drawings).
If there it is a little dent – then use the screwdriver to exhaust the bulge. Again press with the thumb on the seal ring and and keep the pressure while rotating 360° (see drawing 4).
6. It is important to release compressed air behind the seal ring .
This is done with a screwdriver and always underneath the plug as shown.
It must be done at one or two different points on the circumference.
Be careful not to make marks on the surface of the plug seal ring (see drawing 5).

Drawing 1

It is important to place the screwdriver underneath the plug.

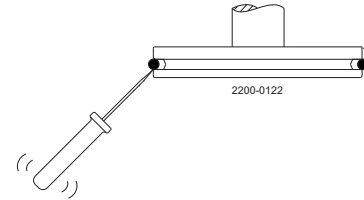

Drawing 2

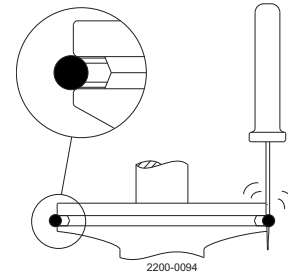

Drawing 3

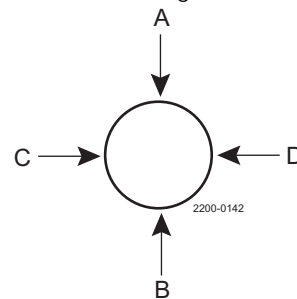

Drawing 4

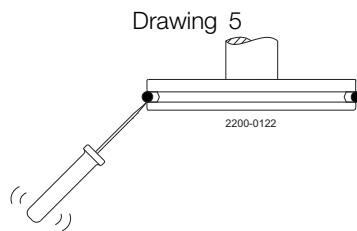
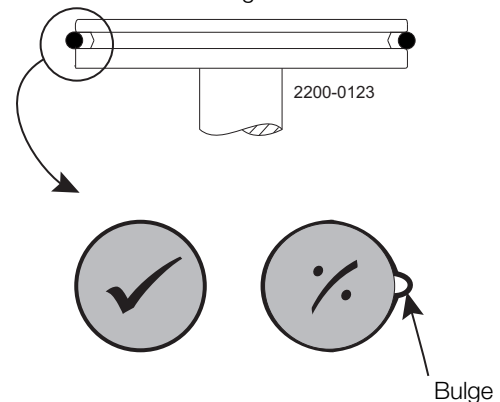

Study the instructions carefully. The items refer to the parts list and service kits section. Handle scrap correctly.

NC = Normally closed.

NO = Normally open.

A/A = Air/air activated.

5.4 Valve assembly

Reverse order of .

Lubricate O-ring (21) and lip seal (25) with Klüber Paraliq GTE 703.

Remember to tighten spindle and plug (use two 17 mm spanners).

- Change-over plug tighten torque = **22 lbf - ft (30 Nm)**
- Shut-off plug tighten torque = **15 lbf - ft (20 Nm)**

If there are vibrations in the pipeline Alfa Laval recommend to use loctite nr. 243.

The clamps thread must be lubricated before tightening - max. torque for the clamps is 8-9 lbf - ft (10-12 Nm).



Pay special attention to the warnings.

5 Maintenance

Study the instructions carefully. The items refer to the parts list and service kits section. Handle scrap correctly.

NC = Normally closed.

NO = Normally open.

A/A = Air/air activated.



5.5 Actuator types

Different actuator types for the SSV valve

In June 2016 the below change was implemented and the “removable yoke with bolts” version is thereby phased out and replaced by the “yoke without bolts” version.

NOTE

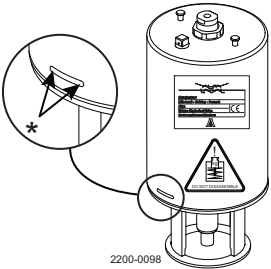
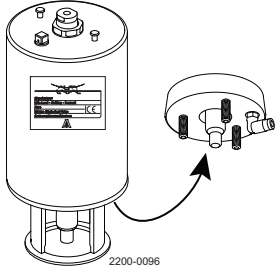
It is important to check for warnings marked on the actuator when servicing an actuator - see below table.

<p>Actuator type</p>	<p>Non-maintainable actuator spring under load and CANNOT be opened</p>  <p>2200-0098</p> <p>*) Lock wire opening is locked, when warning is marked on actuator</p>	<p>Fully maintainable actuator spring cage and can be opened</p>  <p>2200-0096</p>	<p>Fully maintainable actuator spring cage and can be opened</p>  <p>2200-0097</p>
<p>Yoke type</p>	<p>Non-removable yoke</p>	<p>“Removable yoke with bolts”. If the yoke with bolts is damaged it has to be replaced by the “yoke without bolts”</p>	<p>“Yoke without bolts”</p>
<p>Service</p>	<p>Not possible to service internally (it is not possible to change piston o-rings)</p>	<p>Yes</p>	<p>Yes</p>
<p>Marked with warnings</p>	<p>Yes</p>	<p>No</p>	<p>No</p>
<p>Year of production</p>	<p>From 2006</p>	<p>From 2006 to June 2016</p>	<p>From June 2016</p>

Study the instructions carefully.

The items refer to the parts list and service kits section. Handle scrap correctly.

A/A = Air/air activated.

Service tool: see spare parts.

5.6 Actuator bushing replacement (non-maintainable actuator)

If the actuator is marked with a danger warning, do **NOT** attempt to cut the actuator open.



Do **NOT** attempt to disassemble the actuator due to spring under load danger!



Do **NOT** attempt to cut the actuator open due to spring under load danger.



Do **NOT** attempt to cut the actuator open due to spring under load danger.

Step 1

- The actuator service kit contains two bushings and four O-rings.
- Mount the thick o-ring inside and the thin O-ring outside the bushing.
- Always lubricate the spindle and O-rings thoroughly with “Molykote Longterm 2 Plus” before mounting the new bushings.

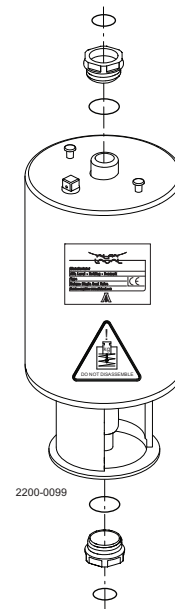

5 Maintenance

Study the instructions carefully.

The items refer to the parts list and service kits section. Handle scrap correctly.

A/A = Air/air activated.

Service tool: see spare parts.

Step 2

Introduction - Standard socket wrench

Use a 1 1/16" (27 mm) socket wrench to mount the bushings, as the space in the yoke is limited.

A socket wrench 24x27 (length = 7 1/4" (185 mm)) is a standard tool, which can be purchased from all tool shops.

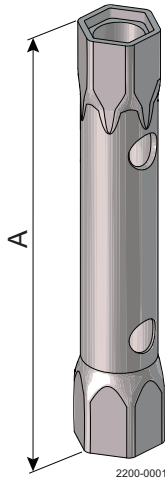

A = 7 1/4" (185 mm)

Example:
Socket wrench - 24x27 mm
Supplier: Gedore Tool
EAN4010886621264

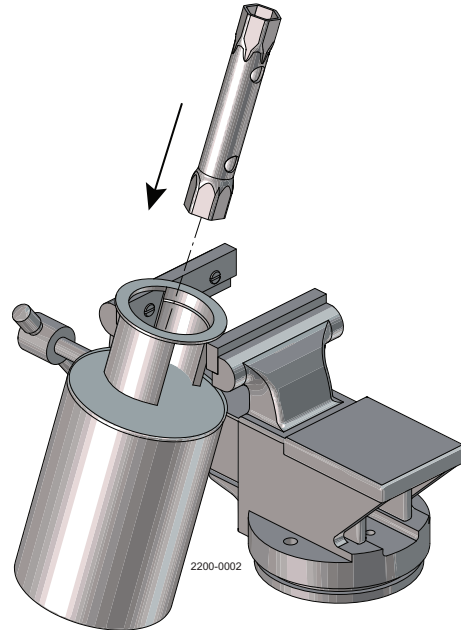

Step 3

Actuator spindle

The actuator spindle can in some cases be forced off centre by the internal spring, see drawing below.

In these cases, the alignment spindle shown below, together with the socket wrench, is a great help and ensures a reliable mounting of the bushing. The spindle can either be purchased from Alfa Laval together with the socket wrench (**9614-1984-01**) or it can be manufactured locally using the below dimensions.

Spindle forced off centre by spring inside actuator

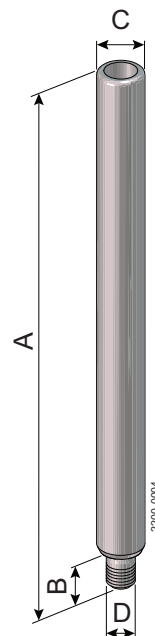
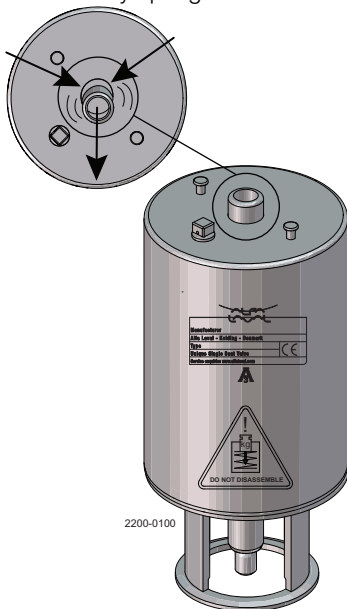

A = 11" (280 mm)
B = 0.63" (16 mm)
C = Rod $\varnothing 0.79"$ ($\varnothing 20$ mm)
D = M12 x 1.5



Study the instructions carefully.

The items refer to the parts list and service kits section. Handle scrap correctly.

A/A = Air/air activated.

Service tool: see spare parts.

Step 4

The actuator must be carefully fixed in a vice - if it is dismantled from the valve. Be careful not to press the yoke flange oval when fixing the actuator in the vice. Only fix carefully on the "yoke leg" as shown below.

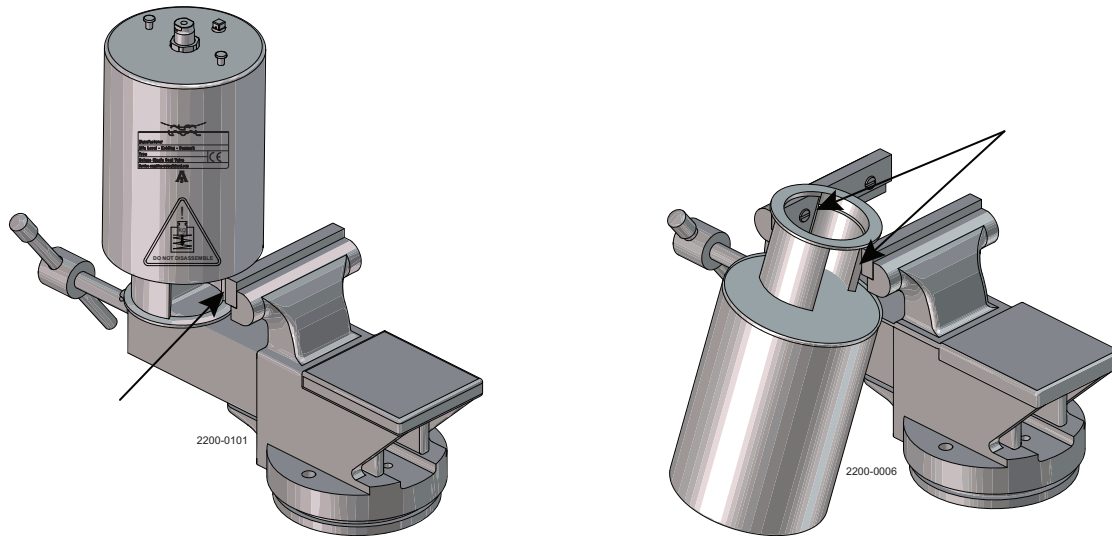

Step 5

Remove adapter screw.

(After spindle alignment the adapter screw has to be remounted.)

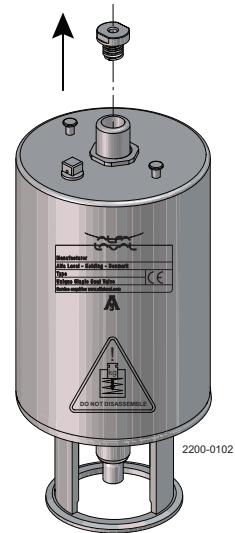

5 Maintenance

Study the instructions carefully.

The items refer to the parts list and service kits section. Handle scrap correctly.

A/A = Air/air activated.

Service tool: see spare parts.

Step 6

1. Lubricate thoroughly both the actuator spindle and O-rings.
2. Grease with "Molykote Longterm 2 plus".
3. Fit the **bushing** on the spindle.

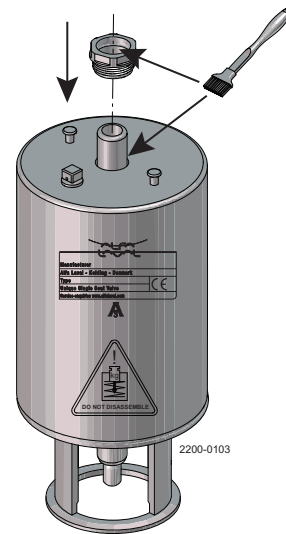

Step 7

Fit the aligning spindle to the actuator spindle, and then mount the socket wrench.

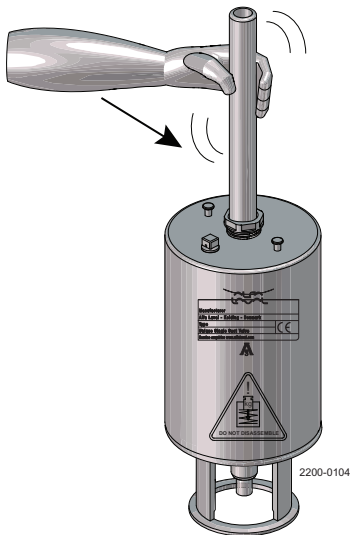

Aligning spindle

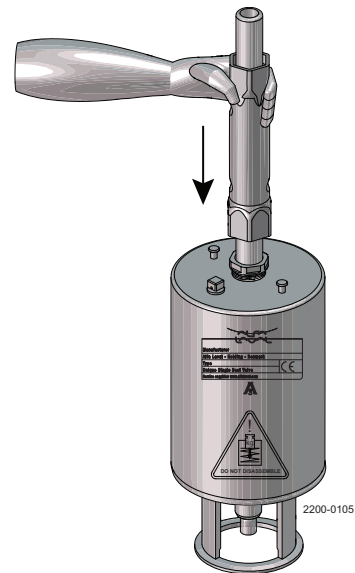

Socket wrench

Study the instructions carefully.

The items refer to the parts list and service kits section. Handle scrap correctly.

A/A = Air/air activated.

Service tool: see spare parts.

Step 8

Now pull the aligning spindle to centre the actuator spindle. In this position rotate the **bushing** 180° backwards and then begin to fasten the bushing. Make sure that the thread catches evenly!

The bushing must only be tightened with a torque of 10 Nm (7 lbf -ft), which can be done by turning “hard” by hand.

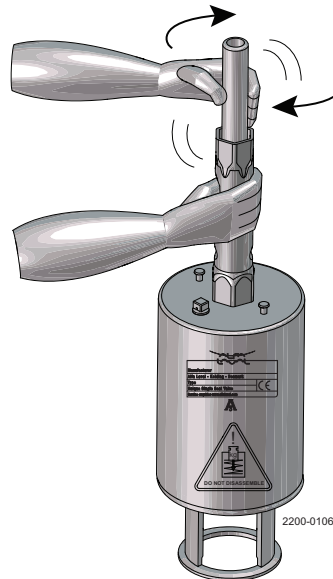

5 Maintenance

Study the instructions carefully.

The items refer to the parts list and service kits section. Handle scrap correctly.

A/A = Air/air activated.

Service tool: see spare parts.

5.7 Dismantling of fully maintainable actuator (removable yoke with bolts/2006-June 2016)

If the actuator is marked with a danger warning, do **NOT** attempt to cut the actuator open.

See also section



Do **NOT** attempt to disassemble the actuator due to spring under load danger!



Do **NOT** attempt to cut the actuator open due to spring under load danger.



Do **NOT** attempt to cut the actuator open due to spring under load danger.

Before dismantling:

Check that the actuator not is marked with a warning.

1. Rotate cylinder.
2. Remove lock wire and pull away cylinder.
3. Unscrew nuts and remove yoke.
4. Top and bottom bushings.
5. Remove piston with O-ring and spring assembly.
6. Remove O-rings and support disc.

Rotate cylinder with service tool.

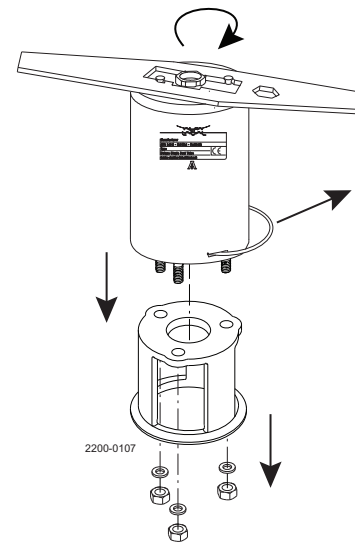

Note! The A/A actuator has no spring assembly.

Study the instructions carefully.

The items refer to the parts list and service kits section. Handle scrap correctly.

A/A = Air/air activated.

Service tool: see spare parts.

5.8 Dismantling of fully maintainable actuator (yoke without bolts/June 2016 ->)

If the actuator is marked with a danger warning, do **NOT** attempt to cut the actuator open.
See also section



Do **NOT** attempt to disassemble the actuator due to spring under load danger!



Do **NOT** attempt to cut the actuator open due to spring under load danger.



Do **NOT** attempt to cut the actuator open due to spring under load danger.

Before dismantling:

Check that the actuator not is marked with a warning.

1. Rotate cylinder.
2. Remove lock wire and pull away cylinder.
3. Top and bottom bushings.
4. Remove piston with O-ring and spring assembly.

Rotate cylinder with service tool.

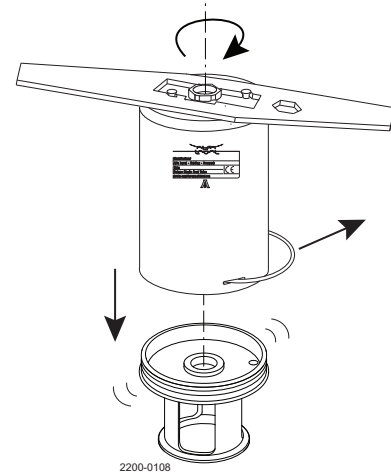

Note! The A/A actuator has no spring assembly.

5 Maintenance

Study the instructions carefully.

The items refer to the parts list and service kits section. Handle scrap correctly.

A/A = Air/air activated.

Service tool: see spare parts.

5.9 Mounting of fully maintainable actuator

Depending on type of actuator choose step 1 or step 2.

Step 1

Reverse order of

Tighten nuts to a torque of 12 lbf - ft (17 Nm).

Lubricate O-rings (3, 7, 11) with Molykote Longterm 2 plus before fitting.

Tighten bushings with a torque = 7 lbf - ft (10 Nm) and be careful not to overtightened. See also section 5,6 for tool information

Step 2

Reverse order of

Lubricate O-rings (3, 7, 11) with Molykote Longterm 2 plus before fitting.

Tighten bushings with a torque = 7 lbf - ft (10 Nm) and be careful not to overtightened.

See also section 5,6 for tool information.



CSI

CONTACT CSI FOR MORE INFORMATION | CSIDESIGNS.COM | SALES@CSIDESIGNS.COM | 417.831.1411

Study the instructions carefully.

The items refer to the parts list and service kits section. Handle scrap correctly.

A/A = Air/air activated.

Service tool: see spare parts.

5.10 Changing pneumatic movement on fully maintainable actuator (NC/NO)

If the actuator is marked with a danger warning, do **NOT** attempt to cut the actuator open.

See also section



Do **NOT** attempt to disassemble the actuator due to spring under load danger!



Do **NOT** attempt to cut the actuator open due to spring under load danger.

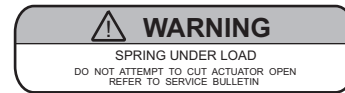

Do **NOT** attempt to cut the actuator open due to spring under load danger.

Before dismantling:

Check that the actuator not is marked with a warning.

1. Rotate cylinder.
2. Remove lock wire and pull away cylinder.
3. Reverse piston and spring assembly.
4. Reverse adapter, air fitting and plug to opposite end.
5. Reassemble in reverse order (3 to 1).

NOTE

The A/A actuator has no spring assembly

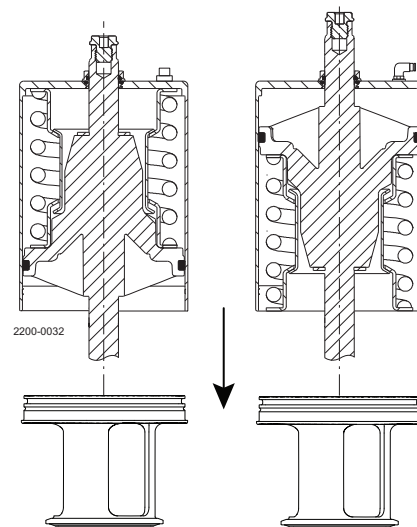

Pneumatic movement upwards

Pneumatic movement downwards

6 Technical data

*It is important to observe the technical data during installation, operation and maintenance.
Inform the personnel about the technical data.*

6.1 Technical data

The valve is a pneumatic seat valve in a hygienic and modular design for a wide field of duties, e.g. as a shut-off valve with two (2) or three (3) ports or as a change-over valve with three (3) to five (5) ports. The valve is remote-controlled by means of compressed air. It has few and simple moveable parts which results in a very reliable valve and low maintenance cost.

Data - valve/actuator	
Max. product pressure	145 PSI (1000 kPa) (10 bar)
Min. product pressure	Full vacuum (depending on product specifications)
Temperature range	14° F to + 221° F (standard TR2 seal)
	14° F to + 284° F (standard EPDM seal)
Air pressure, actuator	72.5 to 101.5 PSI (500 to 700 kPa) (5 to 7 bar)
Materials - valve/actuator	
Product wetted steel parts	AISI 316L (internal Ra < 32 µ inch)
Other steel parts	AISI 304
Plug seal	PTFE (TR2) / EPDM
Other product wetted seals	EPDM (standard)
Optional product wetted seals	HNBR and FPM
Other seals	NBR

Weight (lb)

Nominal size	DN/OD			
	2"	2.5"	3"	4"
Shut-off valve	12.7	14.3	25.6	34.8
Change-over valve	16.1	18.7	36.6	40.3
Shut-of valve: High Pressure	23.1	24.5		
Change-over valve: High Pressure	26.5	28.9		

Noise

3 ft away and 5 ft above the exhaust, the noise level of a valve actuator will be approximately 77db (A) without noise damper and approximately 72 db (A) with damper - Measured at 7 bars air-pressure.



7 Parts list and Service Kits

For parts lists please see section 7.2. The drawing includes all items.

7.1 Unique SSV - Tangential body/Tank Valve

If the actuator is marked with a danger warning, do **NOT** attempt to cut the actuator open. See also section



Do **NOT** attempt to disassemble the actuator due to spring under load danger.



Do **NOT** attempt to cut the actuator open due to spring under load danger.

AND

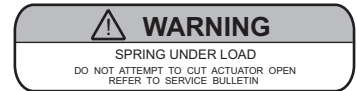

Do **NOT** attempt to cut the actuator open due to spring under load danger.

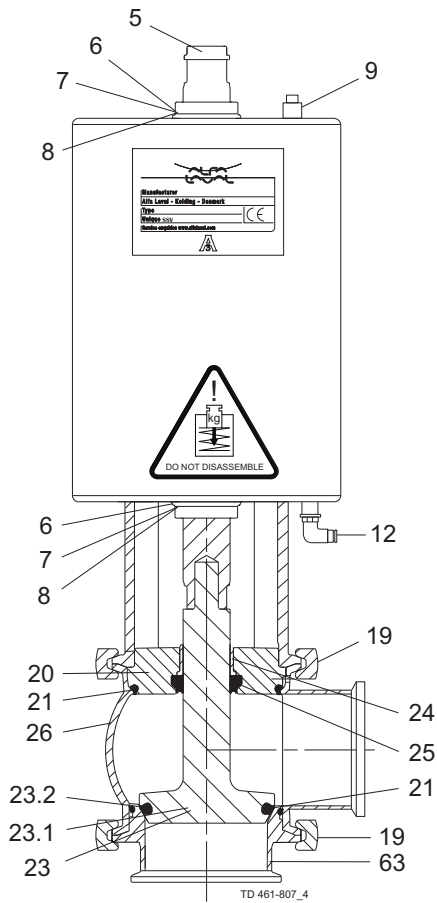

Shut-off valve (elastomer)

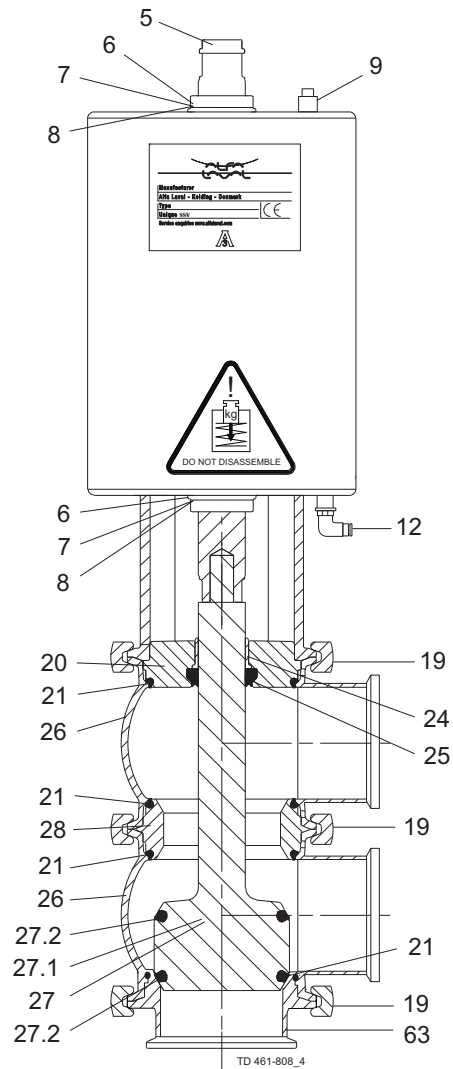

Change-over valve (elastomer)



7 Parts list and Service Kits

For parts lists please see section 7.2. The drawing includes all items.

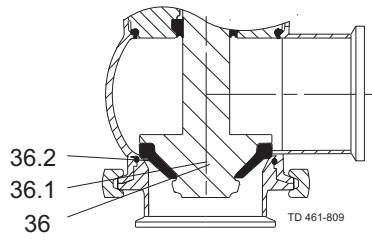

Shut-off valve (TR2)

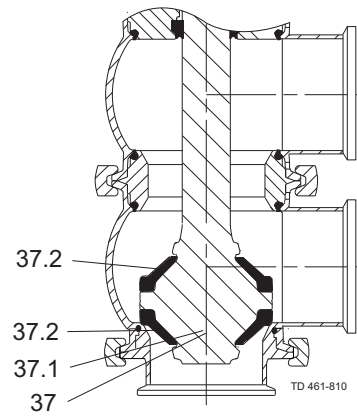

Shut-off valve (TR2)



CSI

CONTACT CSI FOR MORE INFORMATION | CSIDESIGNS.COM | SALES@CSIDESIGNS.COM | 417.831.1411

7 Parts list and Service Kits

For parts lists please see section 7.2. The drawing includes all items.

7.2 Unique SSV Tangential body/Tank Valve - Shut-off-Valve 2"-4"

If the actuator is marked with a danger warning do **NOT** attempt to cut the actuator open.



Do **NOT** attempt to disassemble the actuator due to spring under load danger.



Do **NOT** attempt to cut the actuator open, due to spring under load danger.

AND



Do **NOT** attempt to cut the actuator open, due to spring under load danger.

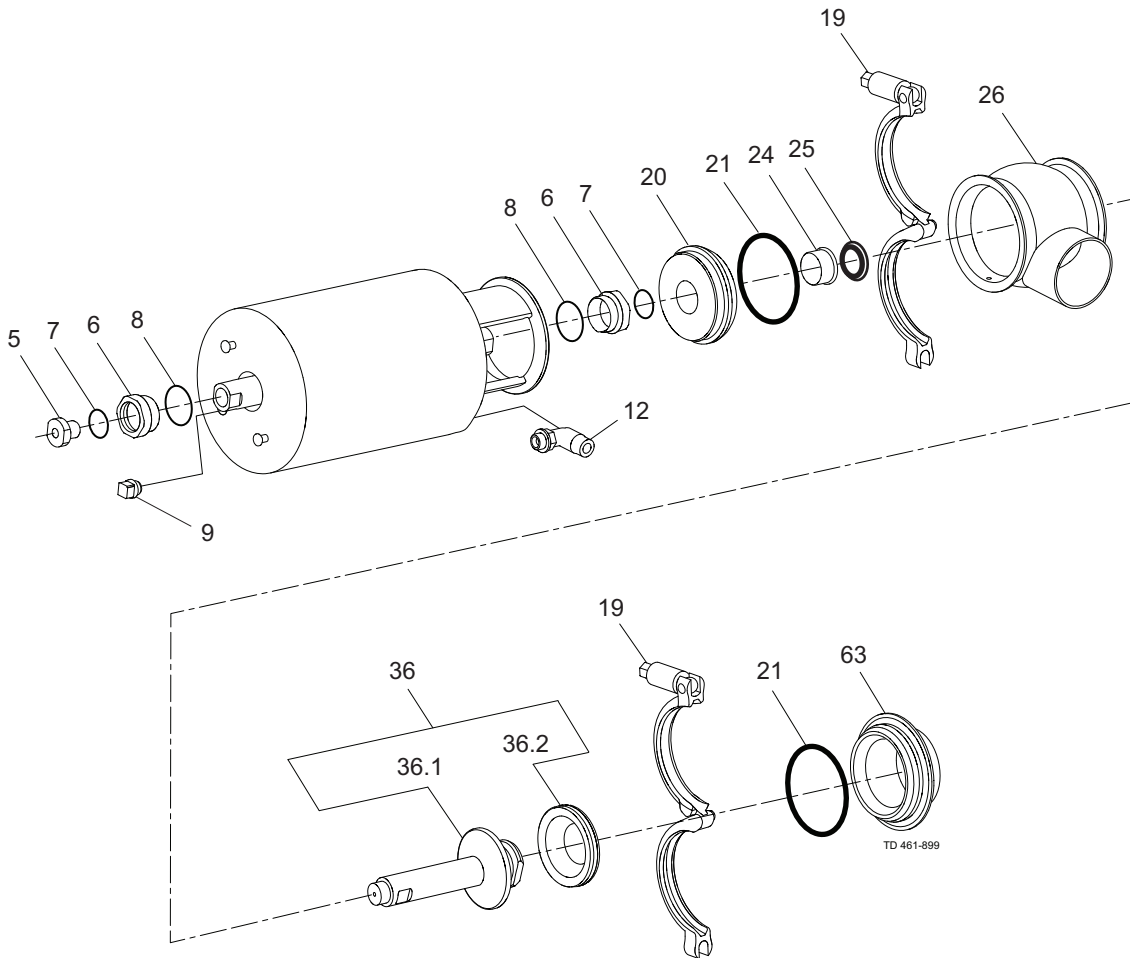

7 Parts list and Service Kits

For parts lists please see section 7.2. The drawing includes all items.

Parts list

Pos.	Qty	Denomination
		Actuator
		Actuator
		Actuator
5	1	Adapter
6 □	2	Bushing
7 □	2	O-ring
8 □	2	O-ring
9	1	Plug
12	1(2)	Air fitting
19	2	Clamp
20	1	Bonnet
21 ♦	2	O-ring
		O-ring
		O-ring
		O-ring
24	1	Bushing
25 ♦	1	Lip seal
		Lip seal
		Lip seal
		Lip seal
26	1	Valve body
	1	Valve body
	1	Valve body
	1	Valve body
36	1	Plug
36.1	1	Plug
36.2 ♦	1	Plug seal
63	1	Port seal element
	1	Port seal element

Service kits

Denomination	2"	2½"	3"	4"
Actuator				
□ Service kit	9611926500	9611926500	9611926500	9611926500
Product wetted parts				
♦ Service kit, EPDM	9611926767	9611926768	9611926769	9611926770
♦ Service kit, HNBR	9611926771	9611926772	9611926773	9611926774
♦ Service kit, FPM	9611926775	9611926776	9611926777	9611926778



7 Parts list and Service Kits

For parts lists please see section 7.2. The drawing includes all items.

7.3 Unique SSV Tangential body/Tank Valve - Change-over Valve 2"-4"

If the actuator is marked with a danger warning do **NOT** attempt to cut the actuator open.



Do **NOT** attempt to disassemble the actuator due to spring under load danger.



Do **NOT** attempt to cut the actuator open, due to spring under load danger.

AND



Do **NOT** attempt to cut the actuator open, due to spring under load danger.

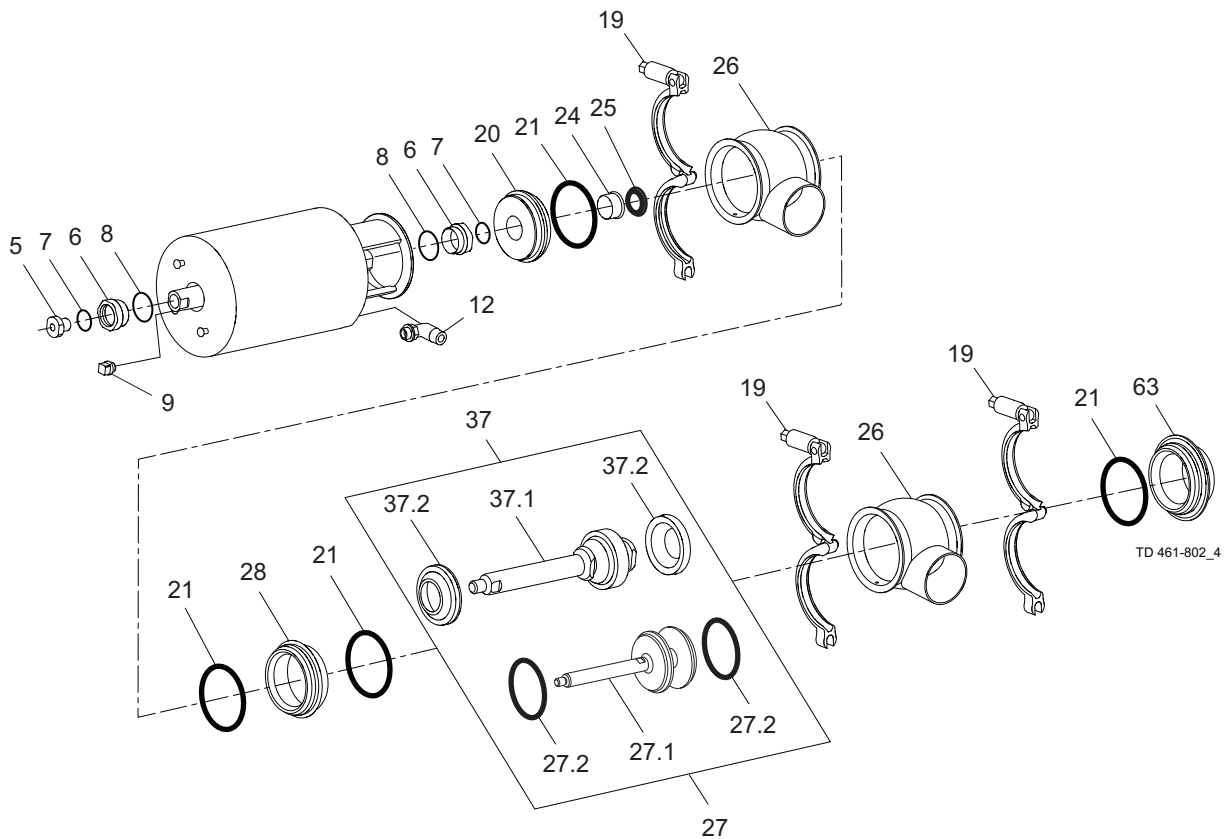

7 Parts list and Service Kits

For parts lists please see section 7.2. The drawing includes all items.

Parts list

Pos.	Qty	Denomination
		Actuator
		Actuator
5	1	Actuator
6	2	Adapter, plastic (- 0115)
7	2	Bushing
8	2	O-ring
9	2	O-ring
12	1	Plug
19	1(2)	Air fitting
20	3	Clamp
21	1	Bonnet
21	4	O-ring
		O-ring
		O-ring
24	1	Bushing
25	1	Lip seal
		Lip seal
		Lip seal
26	2	Valve body
	2	Valve body
	2	Valve body
	2	Valve body
28	1	Seat
37	1	Plug, change-over
37.1	1	Plug
37.2	2	Plug seal
		Plug seal
63	1	Port seal element
	1	Port seal element

Service kits

Denomination	2"	2½"	3"	4"
Actuator				
Service kit	9611926500	9611926500	9611926500	9611926500
Product wetted parts				
Service kit, EPDM	9611926779	9611926780	9611926781	9611926782
Service kit, HNBR	9611926783	9611926784	9611926785	9611926786
Service kit, FPM	9611926787	9611926788	9611926789	9611926790

Recommended spare parts: Service kits

Parts marked with □ are included in the service kits (actuator).

Parts marked with • are included in the service kits (product wetted parts).

TD 900488/2



7 Parts list and Service Kits

For parts lists please see section 7.2. The drawing includes all items.

7.4 Unique SSV maintainable actuator

If the actuator is marked with a danger warning do **NOT** attempt to cut the actuator open.



Do **NOT** attempt to disassemble the actuator due to spring under load danger.



Do **NOT** attempt to cut the actuator open, due to spring under load danger.

AND



Do **NOT** attempt to cut the actuator open, due to spring under load danger.

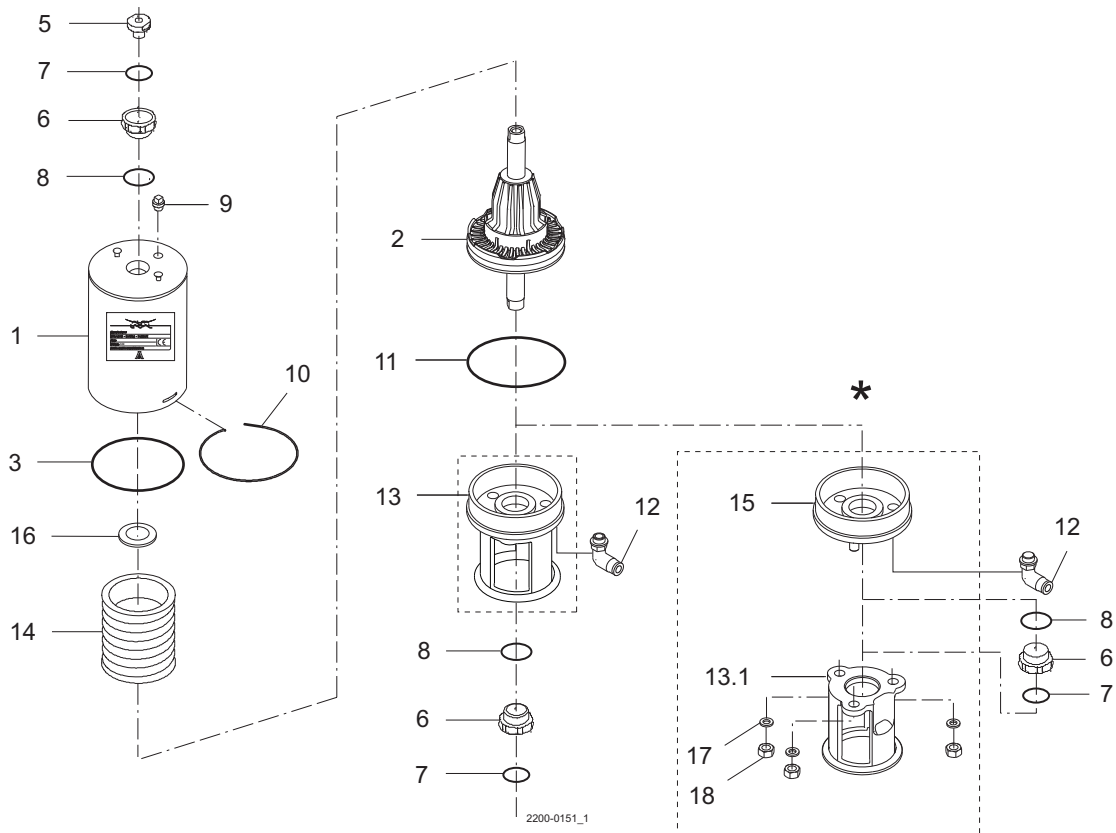

*) Removal yoke with bolts version, produced from 2006 to June 2016.
Phased out with yoke without bolts (13)

7 Parts list and Service Kits

For parts lists please see section 7.2. The drawing includes all items.

Parts list

Pos.	Qty	Denomination
1	1	Cylinder
2	1	Piston
3 ■●	1	O-ring
5	1	Adapter
6 ■●	2	Bushing
7 ■●	2	O-ring
8 ■●	2	O-ring
9	1	Plug
10	1	Lock wire
11 ■●	1	O-ring
12	1/2	Air fitting (only 2 for A/A)
13	1	Yoke
13.1	1	Yoke (-> 0616)
14	1	Spring assembly
15	1	Bottom (-> 0616)
16 ■●	1/2	Support disc (only 2 for A/A)
17	3	Washer (-> 0616)
18	3	Nut (-> 0616)

Service kits

Denomination	1"	1½"	2"	2½"	3"	4"
● Service kit, NO/NC	9611926497	9611926497	9611926498	9611926498	9611926499	9611926499
■ Service kit, A/A	9611926519	9611926519	9611926520	9611926520	9611926521	9611926521



How to contact Alfa Laval

Contact details for all countries are continually updated on our website.

Please visit www.alfalaval.com to access the information directly.

© Alfa Laval Corporate AB

This document and its contents is owned by Alfa Laval Corporate AB and protected by laws governing intellectual property and thereto related rights. It is the responsibility of the user of this document to comply with all applicable intellectual property laws. Without limiting any rights related to this document, no part of this document may be copied, reproduced or transmitted in any form or by any means (electronic, mechanical, photocopying, recording, or otherwise), or for any purpose, without the expressed permission of Alfa Laval Corporate AB. Alfa Laval Corporate AB will enforce its rights related to this document to the fullest extent of the law, including the seeking of criminal prosecution.



CSI

CONTACT CSI FOR MORE INFORMATION | CSIDESIGNS.COM | SALES@CSIDESIGNS.COM | 417.831.1411