

# Instruction Manual

## Unique RV-P, pneumatic regulating valve

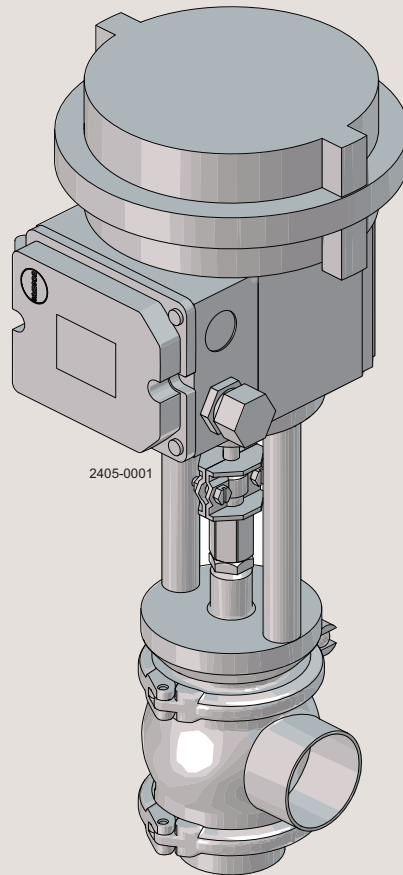

ESE02801-EN3 2020-06

Original manual



**CSI**

CONTACT CSI FOR MORE INFORMATION | [CSIDESIGNS.COM](http://CSIDESIGNS.COM) | [SALES@CSIDESIGNS.COM](mailto:SALES@CSIDESIGNS.COM) | 417.831.1411

# Table of contents

The information herein is correct at the time of issue but may be subject to change without prior notice

<b>1. EC Declaration of Conformity</b> .....	<b>4</b>
<b>2. Safety</b> .....	<b>5</b>
2.1. Important information .....	5
2.2. Warning signs .....	5
2.3. Safety precautions .....	6
<b>3. Installation</b> .....	<b>7</b>
3.1. Unpacking/delivery .....	7
3.2. General installation .....	8
3.3. Welding .....	10
3.4. Recycling information .....	13
<b>4. Operation</b> .....	<b>14</b>
4.1. Operation .....	14
4.2. Troubleshooting .....	16
4.3. Recommended cleaning .....	16
<b>5. Maintenance</b> .....	<b>18</b>
5.1. General maintenance .....	18
5.2. Dismantling the valve .....	20
5.3. Plug seal replacement .....	22
5.4. Valve assembly .....	22
<b>6. Technical data</b> .....	<b>23</b>
6.1. Technical data .....	23
<b>7. Parts list and service kits</b> .....	<b>25</b>
7.1. Standard model .....	25
7.2. Aseptic model .....	28



# 1 EC Declaration of Conformity

Revision of Declaration of Conformity: 2016-06-01

The Designated Company

Alfa Laval Kolding A/S

Company Name

Albuen 31, DK-6000 Kolding, Denmark

Address

+45 79 32 22 00

Phone No.

hereby declares that

Valve

Designation

Unique RV-P, Unique RV-P-A

Type

is in conformity with the following directive with amendments:  
- Machinery Directive 2006/42/EC

The person authorised to compile the technical file is the signer of this document

Global Product Quality Manager  
Pumps, Valves, Fittings and Tank Equipment

Title

Lars Kruse Andersen

Name

Kolding

Place

2016-10-26

Date

Signature



---

*Unsafe practices and other important information are emphasised in this manual.  
Warnings are emphasised by means of special signs.*

---

### 2.1 Important information

---

**Always** read the manual before using the valve!

**WARNING**

Indicates that special procedures must be followed to avoid serious personal injury.

**CAUTION**

Indicates that special procedures must be followed to avoid damage to the valve.

**NOTE**

Indicates important information to simplify or clarify procedures.

---

### 2.2 Warning signs

---

General warning:



Caustic agents:



## 2 Safety

---

All warnings in this manual are summarised on this page.

Pay special attention to this instructions below so that severe personal injury and/or damage to the valve are avoided.

---

### 2.3 Safety precautions

---

#### Installation:

**Always** read the technical data thoroughly (see chapter 6 Technical data)  
**Always** release compressed air after use  
**Never** touch moving parts if the actuator is supplied with compressed air  
**Never** touch the valve or the pipelines when processing hot liquids or when sterilising  
**Never** dismantle the valve with valve and pipelines under pressure  
**Never** dismantle the valve when it is hot



#### Operation:

**Never** dismantle the valve with valve and pipelines under pressure  
**Never** dismantle the valve when it is hot  
**Always** read the technical data thoroughly (see chapter 6 Technical data)  
**Always** release compressed air after use  
**Never** touch the valve or the pipelines when processing hot liquids or when sterilising  
**Never** touch moving parts if the actuator is supplied with compressed air  
**Always** rinse well with clean water after cleaning



**Always** handle lye and acid with great care



#### Maintenance:

**Always** read the technical data thoroughly (see chapter 6 Technical data)  
**Always** release compressed air after use  
**Never** service the valve when it is hot  
**Never** service the valve with valve and pipelines under pressure  
**Never** stick your fingers through the valve ports if the actuator is supplied with compressed air  
**Never** touch moving parts if the actuator is supplied with compressed air  
**Always** use Alfa Laval genuine spare parts. The warranty of Alfa Laval products is dependent on the use of Alfa Laval genuine spare parts.



#### Transportation:

**Always** ensure that compressed air is released  
**Always** ensure that all connections are disconnected before attempting to remove the valve from the installation  
**Always** drain liquid from valves before transportation  
  
**Always** use predesigned lifting points if defined  
**Always** ensure sufficient fixing of the valve during transportation - if specially designed packaging material is available, it must be used

---



CSI

CONTACT CSI FOR MORE INFORMATION | CSIDESIGNS.COM | SALES@CSIDESIGNS.COM | 417.831.1411

*This instruction manual is part of the delivery. Study the instructions carefully.  
The items refer to the parts list and service kits section.  
The valve is assembled before delivery.*

### 3.1 Unpacking/delivery

#### Step 1

##### CAUTION

Alfa Laval cannot be held responsible for incorrect unpacking.

#### Check the delivery for:

1. Complete valve
2. Delivery note
3. Instruction manual

#### Step 2

Remove possible packing materials from the valve/valve parts.

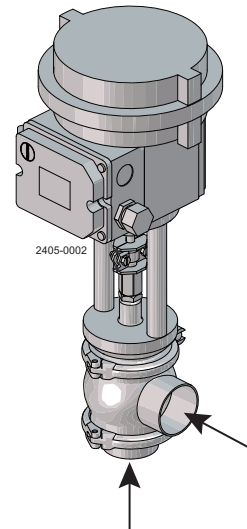

#### Step 3

Inspect the valve for visible transport damage.

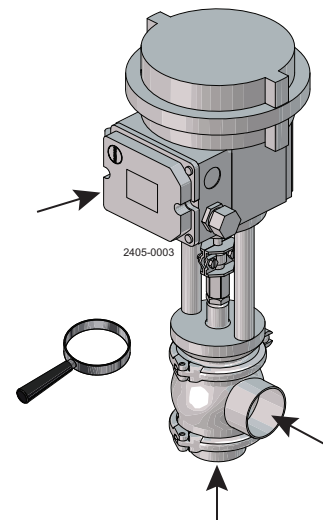

### 3 Installation

Study the instructions carefully and pay special attention to the warnings!  
The valve has welding ends as standard but can also be supplied with fittings.

#### Step 4

Avoid damaging the air connection, the electrical connection and the valve ports.

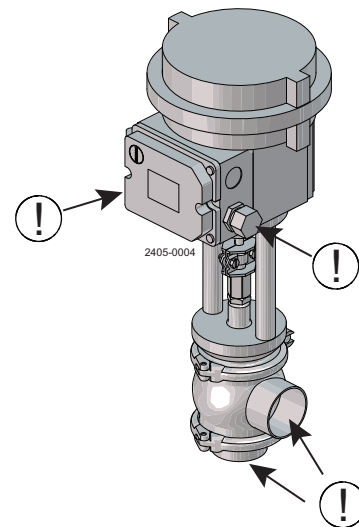

### 3.2 General installation

#### Step 1



**Always** read the technical data thoroughly.  
See chapter 6 Technical data.

**CAUTION**  
Alfa Laval cannot be held responsible for incorrect installation.



**Always** release compressed air after use.

#### Step 2



**Never** touch moving parts if the actuator is supplied with compressed air.

Moving parts!

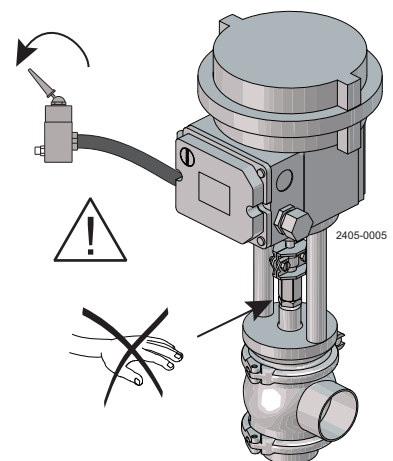



### 3 Installation

Study the instructions carefully and pay special attention to the warnings!  
The valve has welding ends as standard but can also be supplied with fittings.

#### Step 3

To avoid water hammer, it is recommended to install the valve so that the flow is against the closing direction.

Shock in the actuator must **never** occur.

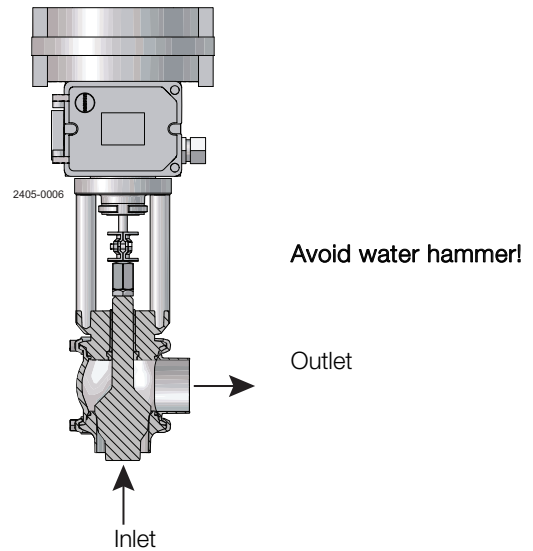

#### Step 4

Avoid stressing the valve.

**Pay special attention to:**

- Vibrations.
- Thermal expansion of the pipelines.
- Excessive welding.
- Overloading of the pipelines.

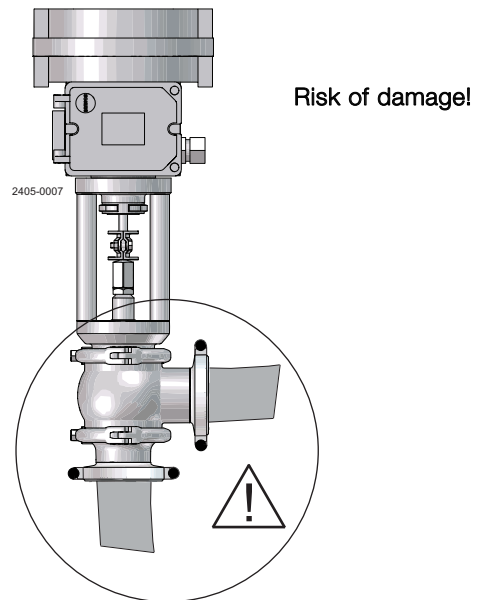

### 3 Installation

Study the instructions carefully.  
The items refer to the parts list and service kits section.  
Check the valve for smooth operation after welding.

#### 3.3 Welding

##### Step 1

**Always** weld the valve body into the system when it is disassembled from the valve.  
Maintain the minimum clearance (A) so that the actuator can be removed.

Valve size	A (mm)
38 mm/DN40	100
51 mm/DN50	105
63.5 mm/DN65	130
76 mm/DN80	145
101.6 mm/DN100	180

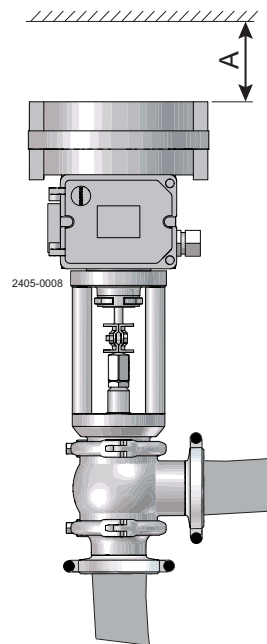

### 3 Installation

Study the instructions carefully.

The items refer to the parts list and service kits section.

Check the valve for smooth operation after welding.

#### Step 2

Assemble the valve in accordance with the steps on page 22.

**Pay special attention to the warnings!**

#### Standard model

1. Lubricate O-ring (21) and lip seal (25) with Klüber Paraliq GTE 703.
2. Fit seat (63) and O-ring (21) in the valve body (26).
3. Fit and tighten lower clamp (19).
4. Fit O-ring (21) and plug (23) in valve body (26).
5. Fit bushing (24) and lip seal (25) in the bonnet (112).
6. Mount the actuator (110) and bonnet (112) together with the valve parts in the valve body (26).
7. Fit and tighten upper clamp (19).
8. Fit and tighten valve plug adjuster (114) and nut (115) to the plug (23).
9. Fit and tighten the clamp fittings (111).

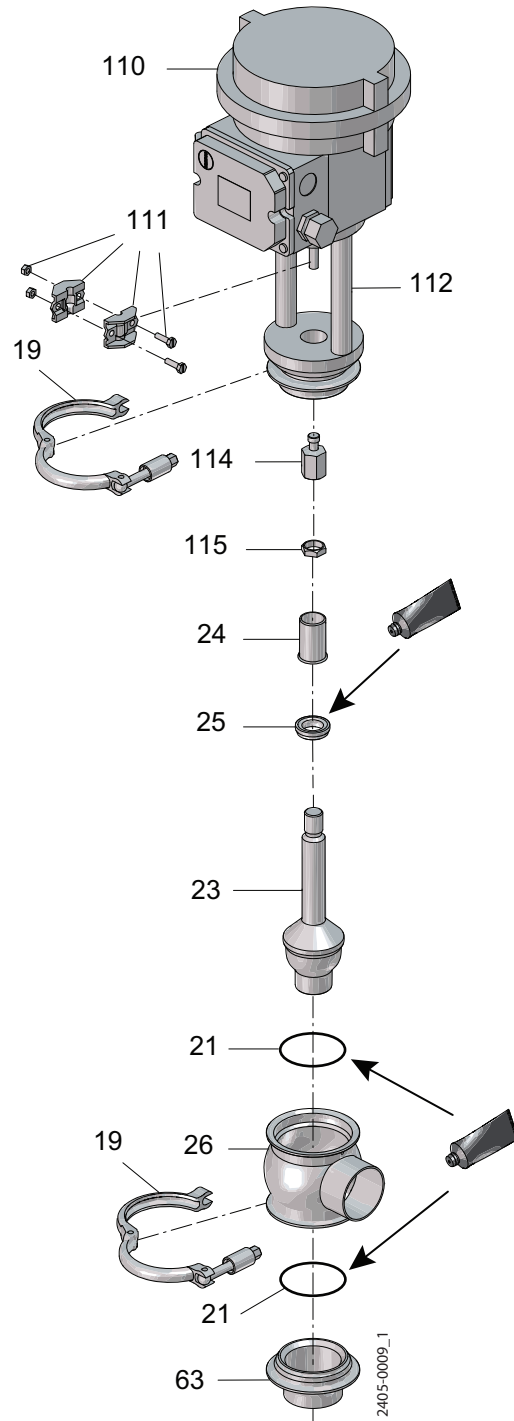

### 3 Installation

Study the instructions carefully.

The items refer to the parts list and service kits section.

Check the valve for smooth operation after welding.

#### Aseptic model

1. Lubricate O-ring (21) with Klüber Paraliq GTE 703.
2. Fit seat (63) and O-ring (21) in the valve body (26).
3. Fit and tighten lower clamp (19).
4. Fit plug (23) in valve body (26).
5. Fit bushing (24) in the bonnet (112).
6. Mount the actuator (110) and bonnet (112) together with the valve parts in the valve body (26).
7. Fit and tighten upper clamp (19).
8. Fit and tighten valve plug adjuster (114) and nut (115) to the plug (23).
9. Fit and tighten the clamp fittings (111).

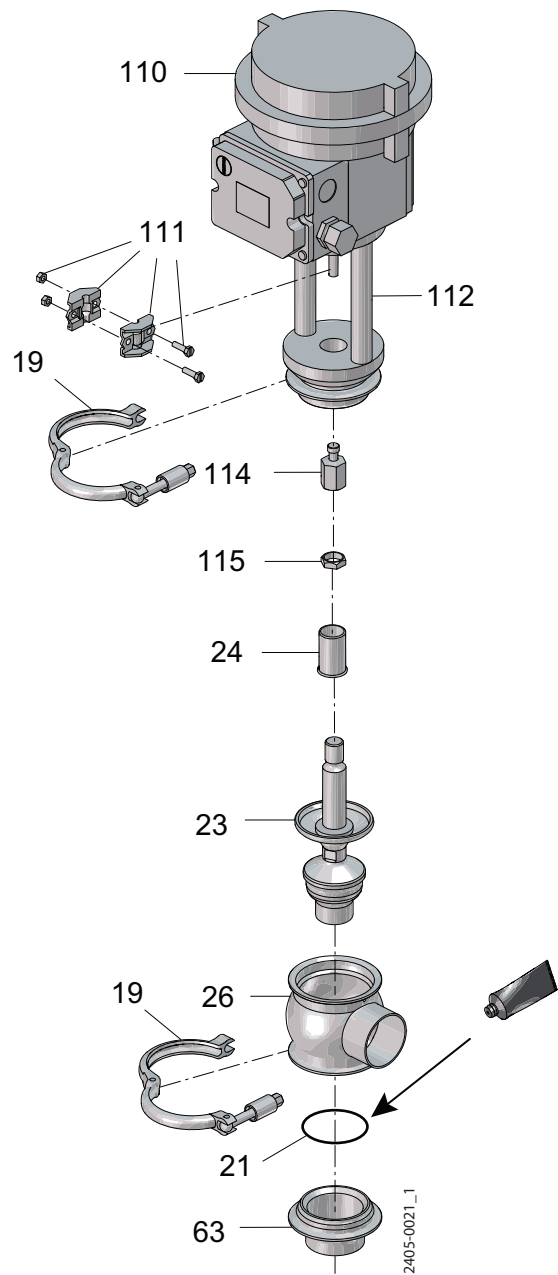

Study the instructions carefully.

The items refer to the parts list and service kits section.

Check the valve for smooth operation after welding.

### Step 3

#### Pre-use check:

1. Activate the valve using compressed air.
2. Open and close the valve several times to ensure that it operates smoothly.

**Pay special attention to the warnings!**

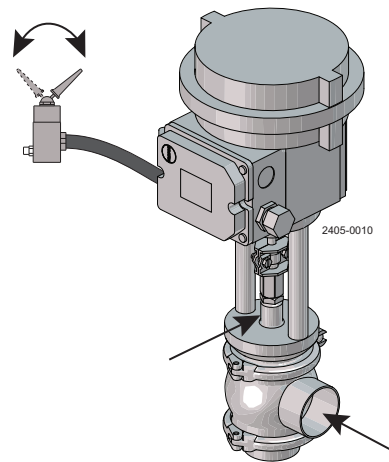

### 3.4 Recycling information

#### • Unpacking

- Packing material consists of wood, plastics, cardboard boxes and, in some cases, metal straps
- Wood and cardboard boxes can be re-used, recycled or used for energy recovery
- Plastics should be recycled or burnt at a licensed waste incineration plant
- Metal straps should be sent for material recycling

#### • Maintenance

- During maintenance, oil and wearing parts in the machine are replaced
- All metal parts should be sent for material recycling
- Worn out or defective electronic parts should be sent to a licensed handler for material recycling
- Oil and all non-metal wear parts must be disposed in accordance with local regulations

#### • Scrapping

- At end of use, the equipment must be recycled according to the relevant local regulations. Besides the equipment itself, any hazardous residues from the process liquid must be considered and dealt with in a proper manner. When in doubt, or in the absence of local regulations, please contact your local Alfa Laval sales company

## 4 Operation

Study the instructions carefully and pay special attention to the warnings!  
Ensure that the valve operates smoothly.  
The items refer to the parts list and service kits section.

### 4.1 Operation

#### Step 1



**Always** read the technical data thoroughly.  
See chapter 6 Technical data.

#### CAUTION

Alfa Laval cannot be held responsible for incorrect operation.



**Always** release compressed air after use.

#### Step 2



**Never** touch the valve or the pipelines when processing hot liquids or when sterilising.

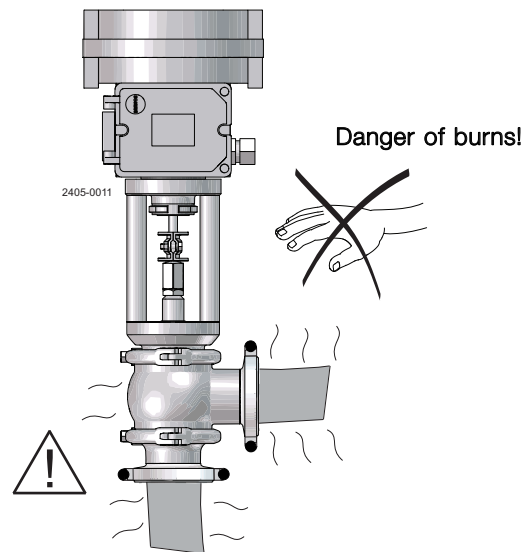

#### Step 3



**Never** touch moving parts if the actuator is supplied with compressed air.

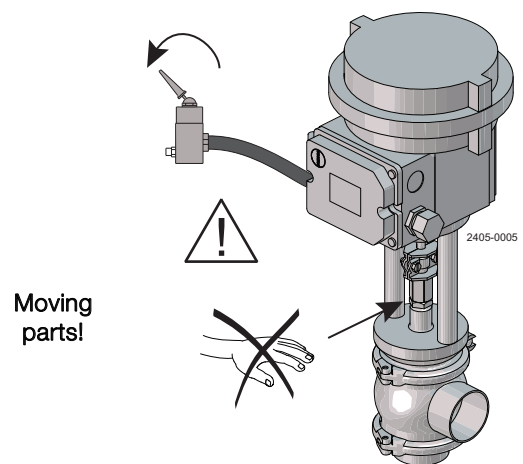

*Study the instructions carefully and pay special attention to the warnings!  
Ensure that the valve operates smoothly.  
The items refer to the parts list and service kits section.*

### Step 4

#### Lubrication of valves:

1. Ensure smooth movement between lip seal (25) and plug stem (23).
2. Lubricate with Klüber Paraliq GTE 703 if necessary (see section 5.1 General maintenance).

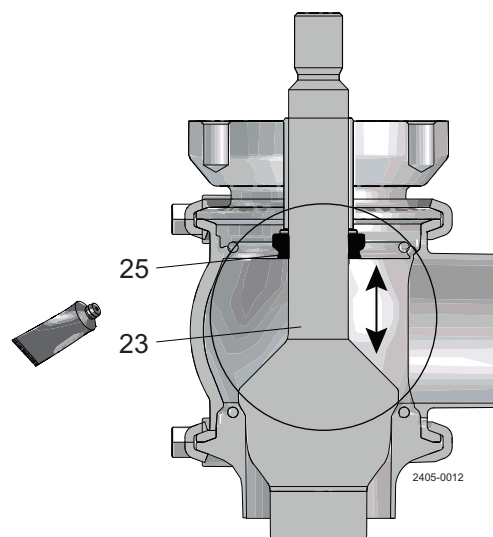

### Step 5

#### Lubrication of actuator

1. Ensure smooth movement of the actuator (the actuator is lubricated before delivery).
2. Lubricate with Molykote Longterm 2 plus if necessary.

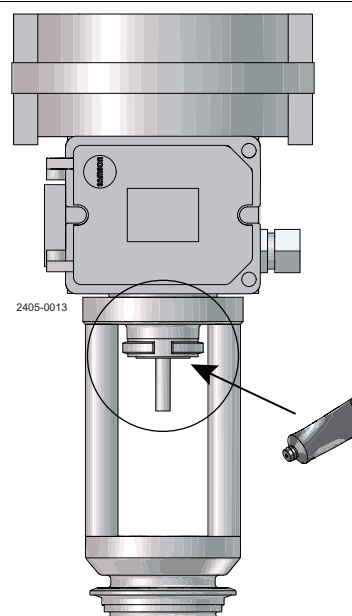

## 4 Operation

Pay attention to possible faults. Study the instructions carefully.  
The items refer to the parts list and service kits section.

### 4.2 Troubleshooting

#### NOTE!

Study the maintenance instructions carefully before replacing worn parts - section 5.1 General maintenance.

Problem	Cause/result	Repair
External product leakage	Worn or damaged lip seal and/or O-ring	<ul style="list-style-type: none"><li>- Replace the seals</li><li>- Replace with seals of a different rubber grade</li></ul>
Internal product leakage	<ul style="list-style-type: none"><li>- Worn or product-affected plug seal</li><li>- Product deposits on the seat and/or plug</li></ul>	<ul style="list-style-type: none"><li>- Replace the seal</li><li>- Replace with a seal of a different rubber grade</li><li>- Frequent cleaning</li></ul>
Water hammer	The flow direction is the same as the closing direction	<ul style="list-style-type: none"><li>- The flow direction should be against the closing direction</li><li>- Throttle air release of solenoid in top unit</li></ul>

### 4.3 Recommended cleaning

#### Step 1



**Always** handle lye and acid with great care.

**Caustic danger!**



**Always** use rubber gloves!



**Always** use protective goggles!

#### Step 2



**Never** touch the valve or the pipelines when sterilising.

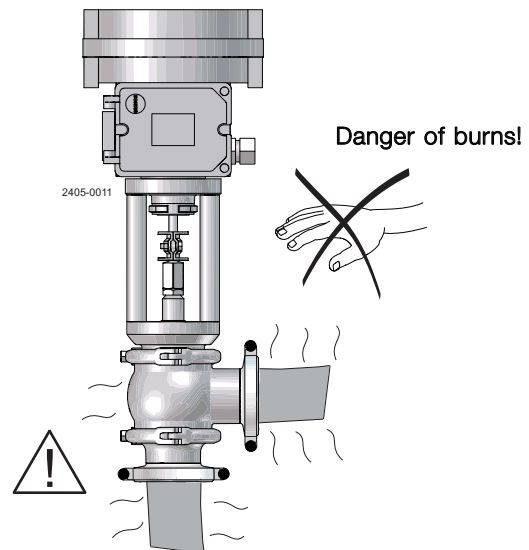



The valve is designed for cleaning in place (CIP).  
 Study the instructions carefully and pay special attention to the warnings!  
 NaOH = Caustic soda.  
 HNO<sub>3</sub> = Nitric acid.

### Step 3

Clean the plug and the seats correctly.  
**Pay special attention to the warnings**  
**Lift and lower valve plug momentarily!**

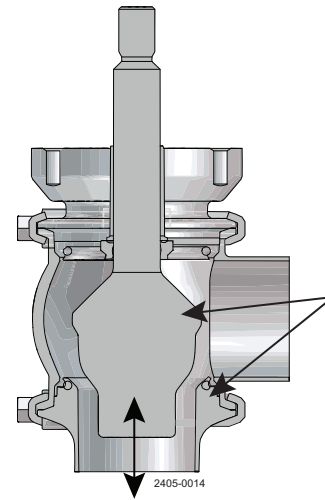

### Step 4

#### Examples of cleaning agents:

Use clean water, free from chlorides.

1. 1% by weight NaOH at 70°C

1 kg NaOH	+	100 l water	=	Cleaning agent.
--------------	---	----------------	---	-----------------

2.2 l 33% NaOH	+	100 l water	=	Cleaning agent.
-------------------	---	----------------	---	-----------------

2. 0.5% by weight HNO<sub>3</sub> at 70°C

0.7 l 53% HNO <sub>3</sub>	+	100 l water	=	Cleaning agent.
-------------------------------	---	----------------	---	-----------------

### Step 5

1. Avoid excessive concentration of the cleaning agent.
2. Adjust the cleaning flow to the process.
3. **Always** rinse well with clean water after cleaning.

#### NOTE

The cleaning agents must be stored/disposed of in accordance with current regulations/directives.

**Always rinse!**



Clean water    Cleaning agents

## 5 Maintenance

Maintain the valve regularly.

Study the instructions carefully and pay special attention to the warnings!

Always keep spare rubber seals and lip seals in stock. Always use Alfa Laval genuine spare parts.

Check the valve for smooth operation after service.

### 5.1 General maintenance

#### Step 1



**Always** read the technical data thoroughly.  
See chapter 6 Technical data



**Always** release compressed air after use.

#### NOTE

All scrap must be stored/discharged in accordance with current regulations/directives.

#### Step 2



**Never** service the valve when it is hot.



**Never** service the valve with valve and pipelines under pressure.

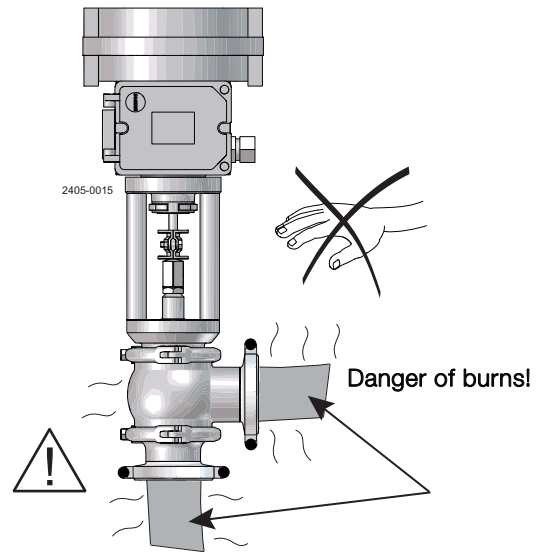

#### Step 3



**Never** stick your fingers through the valve ports if the actuator is supplied with compressed air.

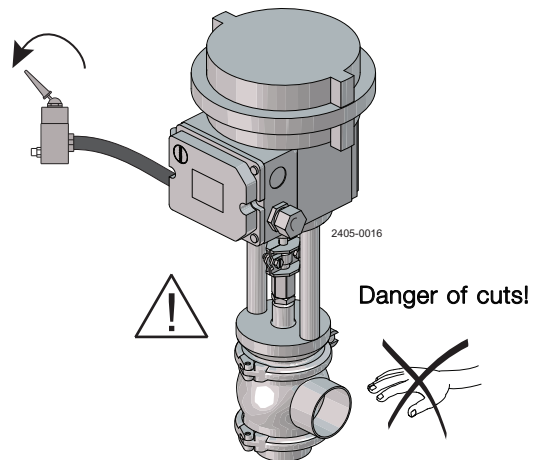

## 5 Maintenance

Maintain the valve regularly.

Study the instructions carefully and pay special attention to the warnings!

Always keep spare rubber seals and lip seals in stock. Always use Alfa Laval genuine spare parts.

Check the valve for smooth operation after service.

### Step 4



**Never** touch the moving parts if the actuator is supplied with compressed air.

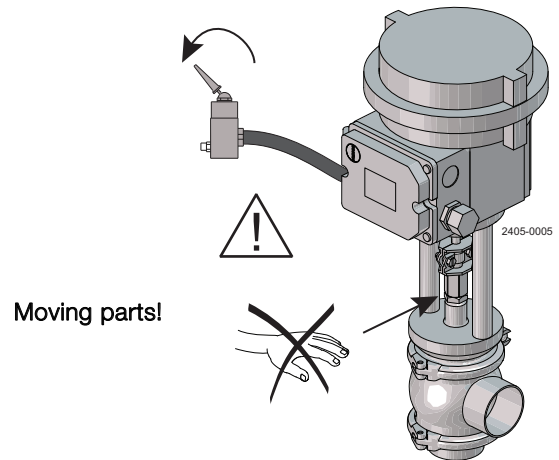

Below are some guidelines for maintenance and lubrication intervals.

Please note that the guidelines are for normal working conditions in one shift.

	Product wetted seals
Preventive maintenance	Replace after 12 months depending on working conditions
Maintenance after leakage (leakage normally starts slowly)	Replace at the end of the day
Planned maintenance	<ul style="list-style-type: none"> <li>- Regular inspection for leakage and smooth operation</li> <li>- Keep a record of the valve</li> <li>- Use the statistics for inspection planning</li> </ul> <b>Replace after leakage</b>
Lubrication	<b>Before fitting</b> Klüber Paraliq GTE 703 or similar USDA H1 approved oil/grease

### Pre-use check:

1. Supply compressed air to the actuator.
2. Activate the positioner program P15 to initialise the positioner.

**Pay special attention to the warnings!**

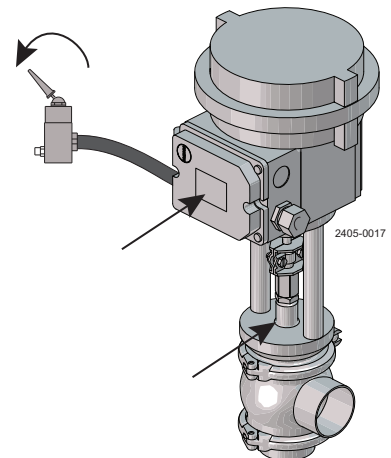

## 5 Maintenance

Study the instructions carefully. The items refer to the parts list and service kits section. Handle scrap correctly.

NC = Normally closed.

NO = Normally open.

### 5.2 Dismantling the valve

#### Step 1

##### Standard model

1. Loosen and remove upper clamp (19).
2. Unscrew the clamp fitting (111).
3. Unscrew the valve plug adjuster (114) and nut (115)
4. Lift away the actuator (110) and bonnet (112)
5. Remove valve plug (23)
6. Loosen and remove lower clamp (19)
7. Remove O-ring (21), lip seal (25) and bushing (24)
8. Remove seat (63) and O-ring (21) from valve body (26)

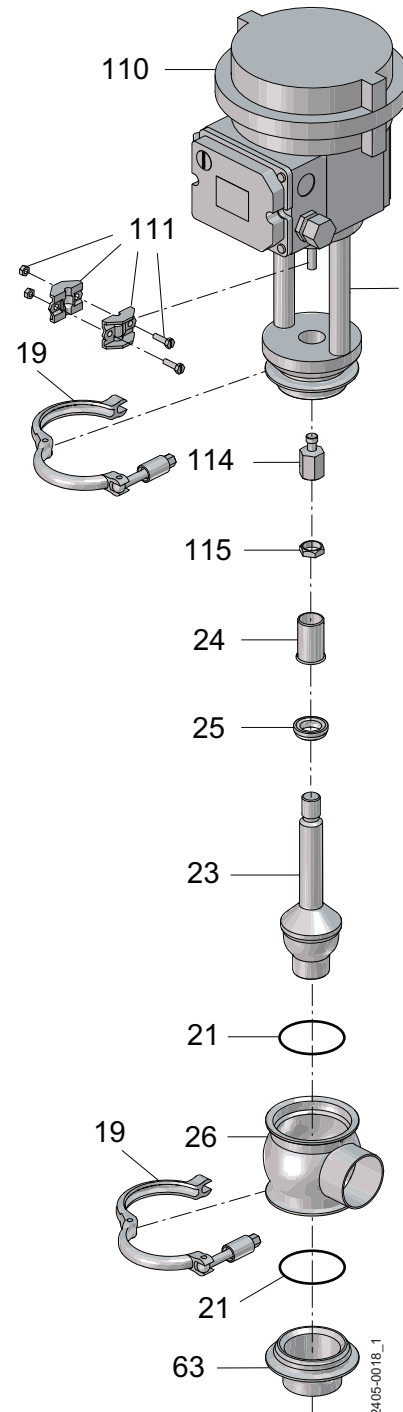

## 5 Maintenance

Study the instructions carefully. The items refer to the parts list and service kits section. Handle scrap correctly.

NC = Normally closed.

NO = Normally open.

### Aseptic model

1. Loosen and remove upper clamp (19).
2. Unscrew the clamp fitting (111).
3. Unscrew the valve plug adjuster (114) and nut (115)
4. Lift away the actuator (110) and bonnet (112)
5. Remove valve plug (23)
6. Loosen and remove lower clamp (19)
7. Remove bushing (24)
8. Remove seat (63) and O-ring (21) from valve body (26)

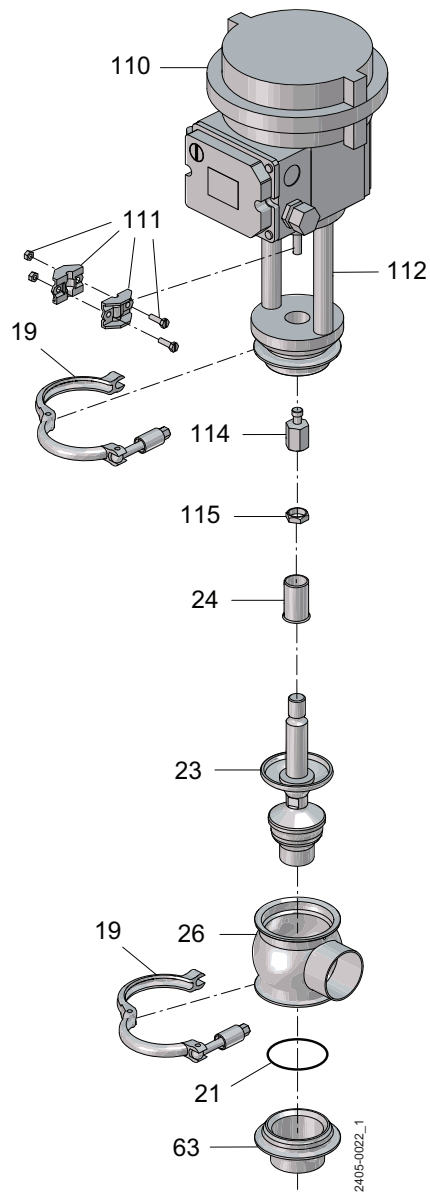

Pay special attention to the warnings!

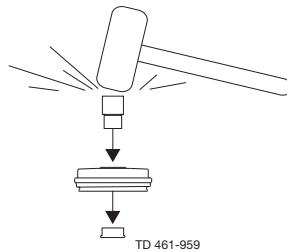

### Note!

Be careful not to damage the bushing.



## 5 Maintenance

---

Study the instructions carefully. The items refer to the parts list and service kits section. Handle scrap correctly.

NC = Normally closed.

NO = Normally open.

---

### 5.3 Plug seal replacement

---

1. Remove the old seal ring using a knife, screwdriver or similar.  
Be careful not to damage metal parts.
2. Pre-mount plug seal without pressing it into the groove.
3. Squeeze plug seal into the groove using opposite pressure points.
4. Release compressed air behind plug seal.

**Note!** For plug seal replacement, please read the instructions in the service kit.

---

### 5.4 Valve assembly

---

Reverse the order of section 5.2 Dismantling the valve.

Lubricate O-ring (21) and lip seal (25) with Klüber Paraliq GTE 703.

Remember to tighten spindle and plug to a torque of 30 Nm (using two 17 mm spanners).

If there are vibrations in the pipeline, Alfa Laval recommends the use of Loctite no. 243.

---

Technical data must be observed during installation, operation and maintenance.  
All personnel should be informed about the technical data

### 6.1 Technical data

#### Working principles

The Product is remote-controlled by an electrical signal and compressed air. The IP-converter, which is an integrated part of the actuator, converts the electrical signal to a pneumatic signal. This signal conversion is extremely insensitive to pressure shocks. The pneumatic signal is transmitted to the integrated positioner which operates by means of the force-balance principle, ensuring that the position of the actuator piston is directly proportional to the input signal.

#### Valve

Data	
Max. product pressure	1000 kPa (10 bar)
Min. product pressure	Full vacuum
Temperature range	-10°C to +140°C (EPDM)
Flow range Kv	0.5 to 110 m <sup>3</sup> /h/bar
Materials	
Product wetted steel parts	AISI 316L
Other steel parts	AISI 304
Lip seal	EPDM (standard)
Finish	Semi-bright

#### Actuator

Air data	
Connection	6/4 mm air tube
Max. air pressure	600 kPa (6 bar)
Working pressure	400 kPa (4 bar)
Max. size of particles	0.01 mm
Max. oil content	0.08 ppm
Dew point	10°C below ambient temp. or lower
Max. water content	7.5 g/kg
Transducer/convector	
Signal range	4-20 mA (standard)
Input resistance	200 W
Inductivity/capacitance	Negligible
Accuracy	
Deviation	≤1.5%
Hysteresis	≤0.5%
Sensitivity	<0.1%
Influence of air supply	≤0.1% between 1.4 and 6 bar
Data	
Protection class	IP66
Ambient temperature	-20°C to +80°C
Materials	
Housing	Aluminium with plastic coating
Diaphragm	NBR with reinforced fabric insert
Springs	Stainless steel uncovered/spring steel epoxy resin coated
Stem	Stainless steel
Plastic parts	Polycarbonate/polyamide 6.6
Screws, nuts	Stainless steel, polyamide 6.6
Other parts	Stainless steel and aluminium

## 6 Technical data

---

*Technical data must be observed during installation, operation and maintenance.  
All personnel should be informed about the technical data*

---

### Weights

Size	38 mm/1½"	51 mm/2"	63.5 mm/2½"	76.1 mm/3"	101.6 mm/4" NO	101.6 mm/4" NC
kg	8.2	9.3	9.7	11.2	15.4	24.9

### Noise

One metre away from and 1.6 metres above the exhaust the noise level of a valve actuator will be approximately 77 db(A) without noise damper and approximately 72 db(A) with damper - measured at 7 bar air pressure.

---



## 7 Parts list and service kits

**Always** use Alfa Laval genuine spare parts. The warranty of Alfa Laval products is dependent on the use of Alfa Laval genuine spare parts.

### 7.1 Standard model

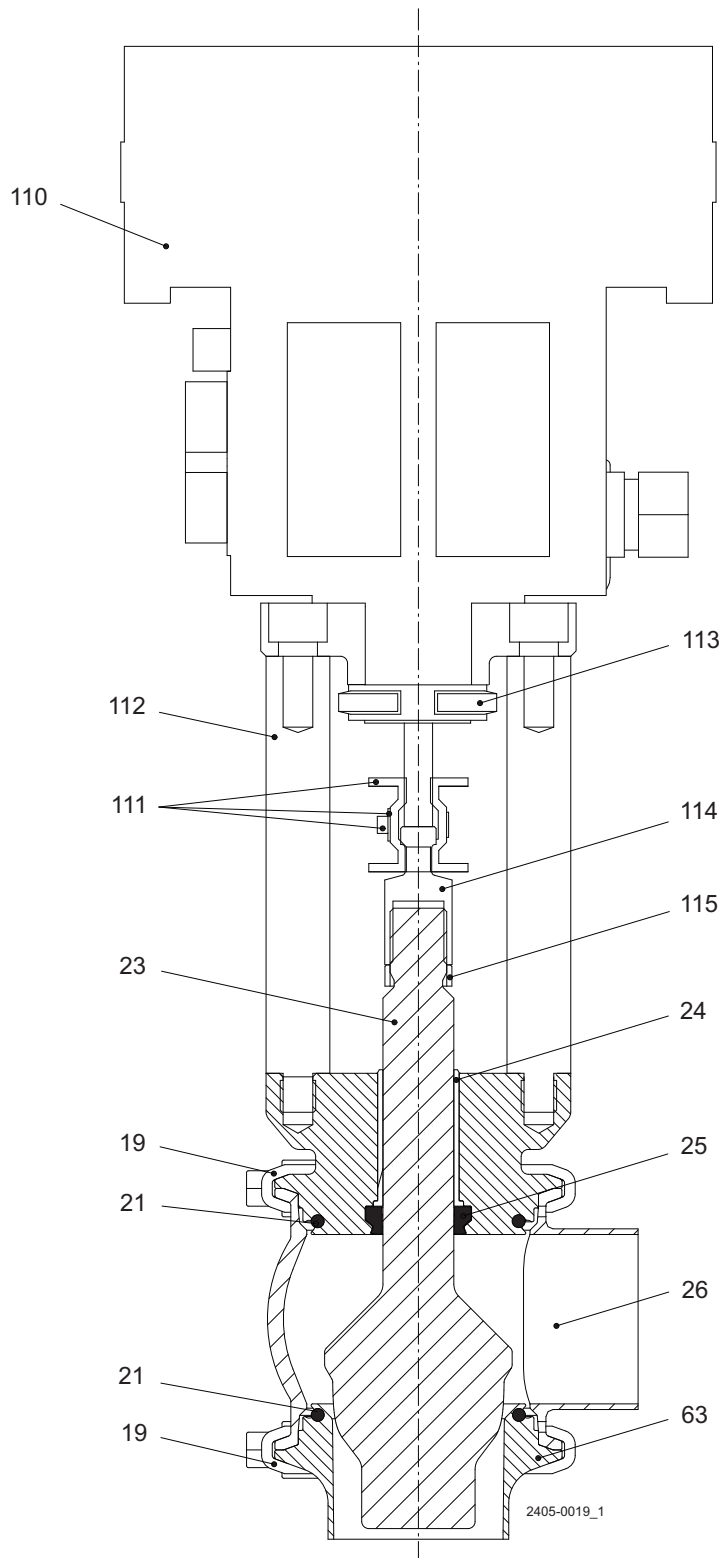

## 7 Parts list and service kits

**Always** use Alfa Laval genuine spare parts. The warranty of Alfa Laval products is dependent on the use of Alfa Laval genuine spare parts.

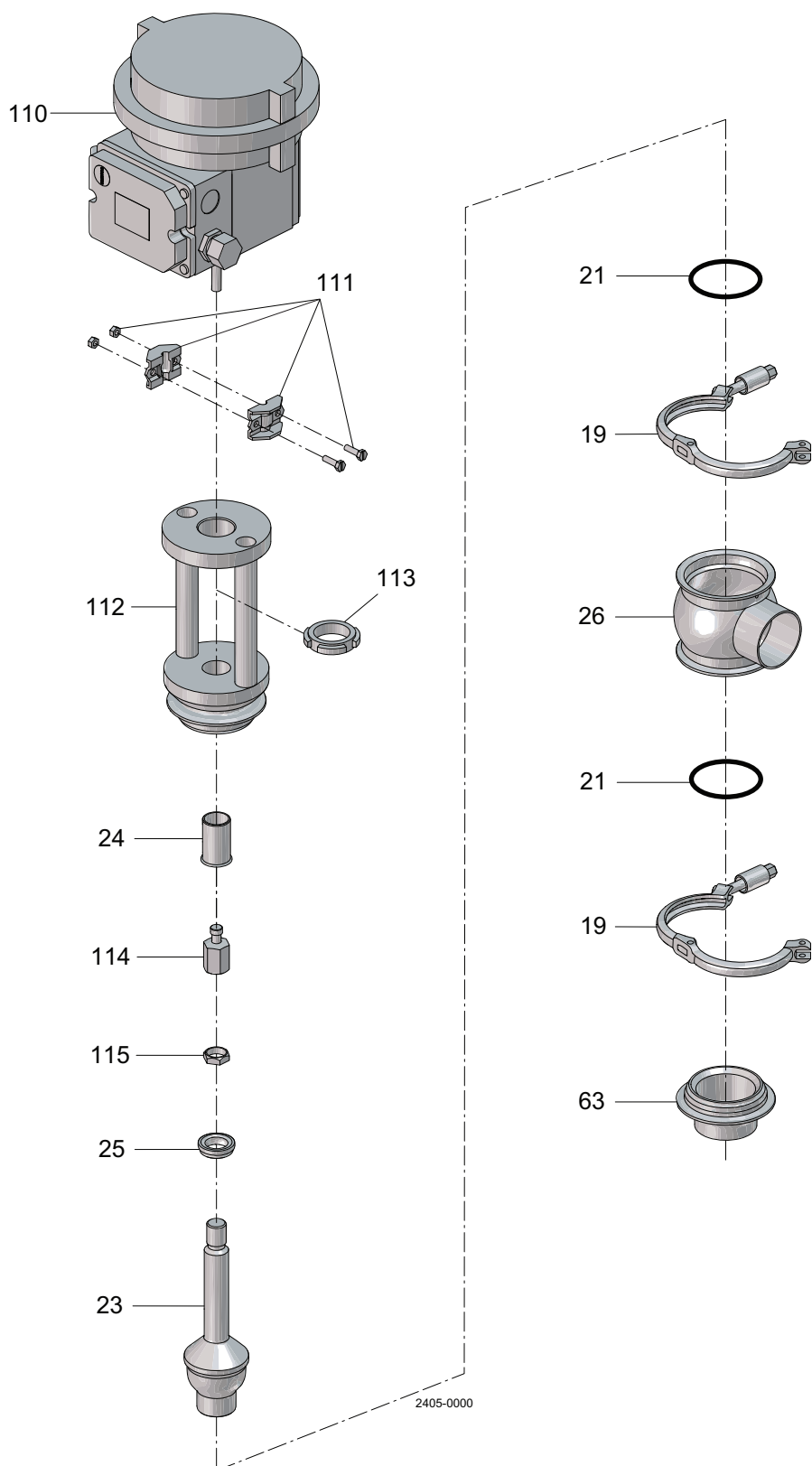

CSI

CONTACT CSI FOR MORE INFORMATION | CSIDESIGNS.COM | SALES@CSIDESIGNS.COM | 417.831.1411

## 7 Parts list and service kits

**Always** use Alfa Laval genuine spare parts. The warranty of Alfa Laval products is dependent on the use of Alfa Laval genuine spare parts.

### Parts list

Pos.	Qty	Denomination
19	2	Clamp
21 *	2	O-ring
23	1	Plug
24	1	Bushing
25 *	1	Lip seal
26	1	Valve body
63	1	Seat
110	1	Actuator, complete
111	1	Clamp fitting
112	1	Bonnet, complete
113	1	Striking nut
114	1	Valve plug adjuster
115	1	Nut

### Service kits

Denomination	38 mm DN40	51 mm DN50	63.5 mm DN65	76.1 mm DN80	101.6 mm DN100
* Service kit, EPDM .....	9611926975	9611926976	9611926977	9611926978	9611926979
* Service kit, HNBR .....	9611926980	9611926981	9611926982	9611926983	9611926984
* Service kit, FPM .....	9611926985	9611926986	9611926987	9611926988	9611926989

Parts marked with \* are included in the service kits.

Recommended spare parts: Service kits.

900679/2



## 7 Parts list and service kits

**Always** use Alfa Laval genuine spare parts. The warranty of Alfa Laval products is dependent on the use of Alfa Laval genuine spare parts.

### 7.2 Aseptic model

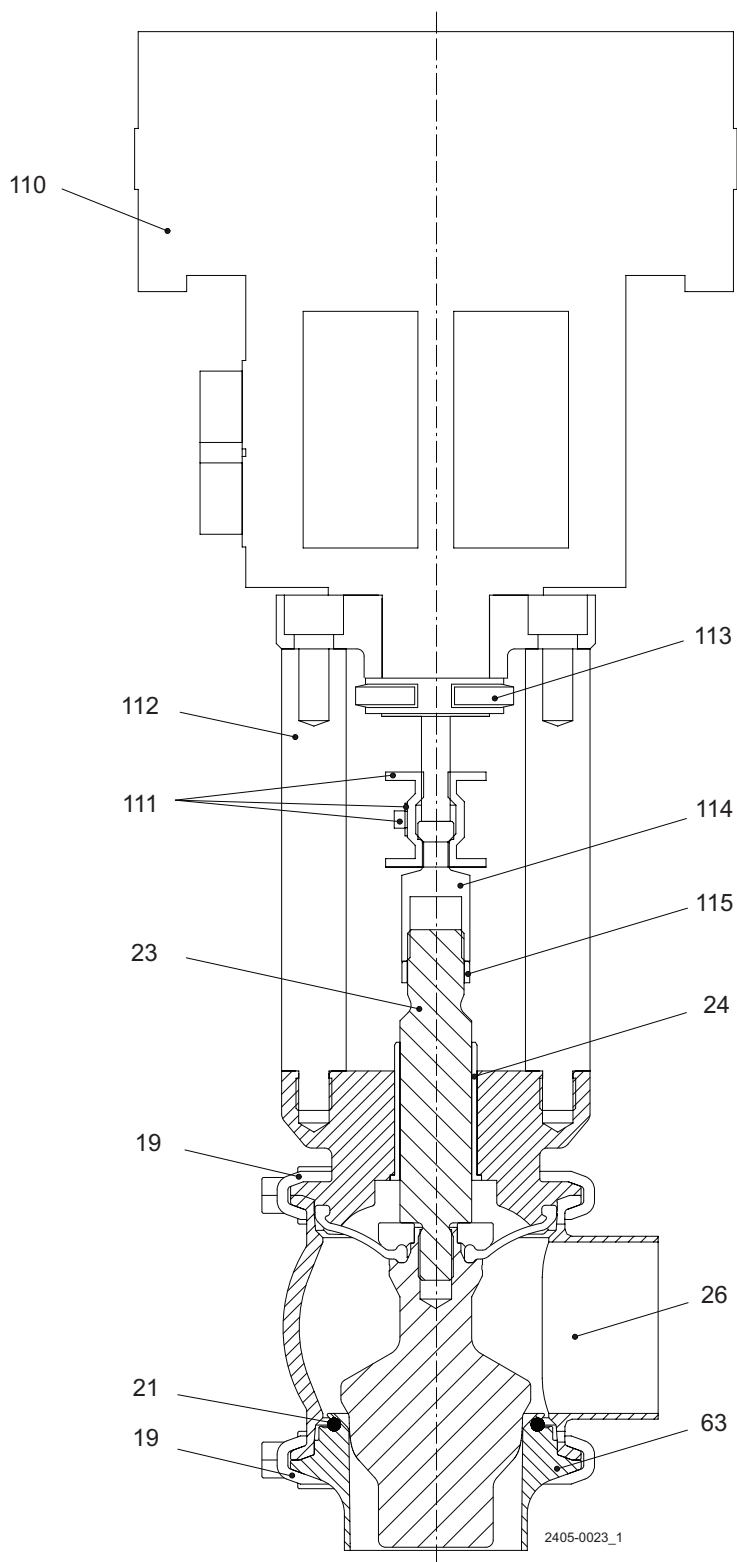

## 7 Parts list and service kits

---

**Always** use Alfa Laval genuine spare parts. The warranty of Alfa Laval products is dependent on the use of Alfa Laval genuine spare parts.

---



**CSI**

CONTACT CSI FOR MORE INFORMATION | [CSIDESIGNS.COM](http://CSIDESIGNS.COM) | [SALES@CSIDESIGNS.COM](mailto:SALES@CSIDESIGNS.COM) | 417.831.1411

## 7 Parts list and service kits

**Always** use Alfa Laval genuine spare parts. The warranty of Alfa Laval products is dependent on the use of Alfa Laval genuine spare parts.

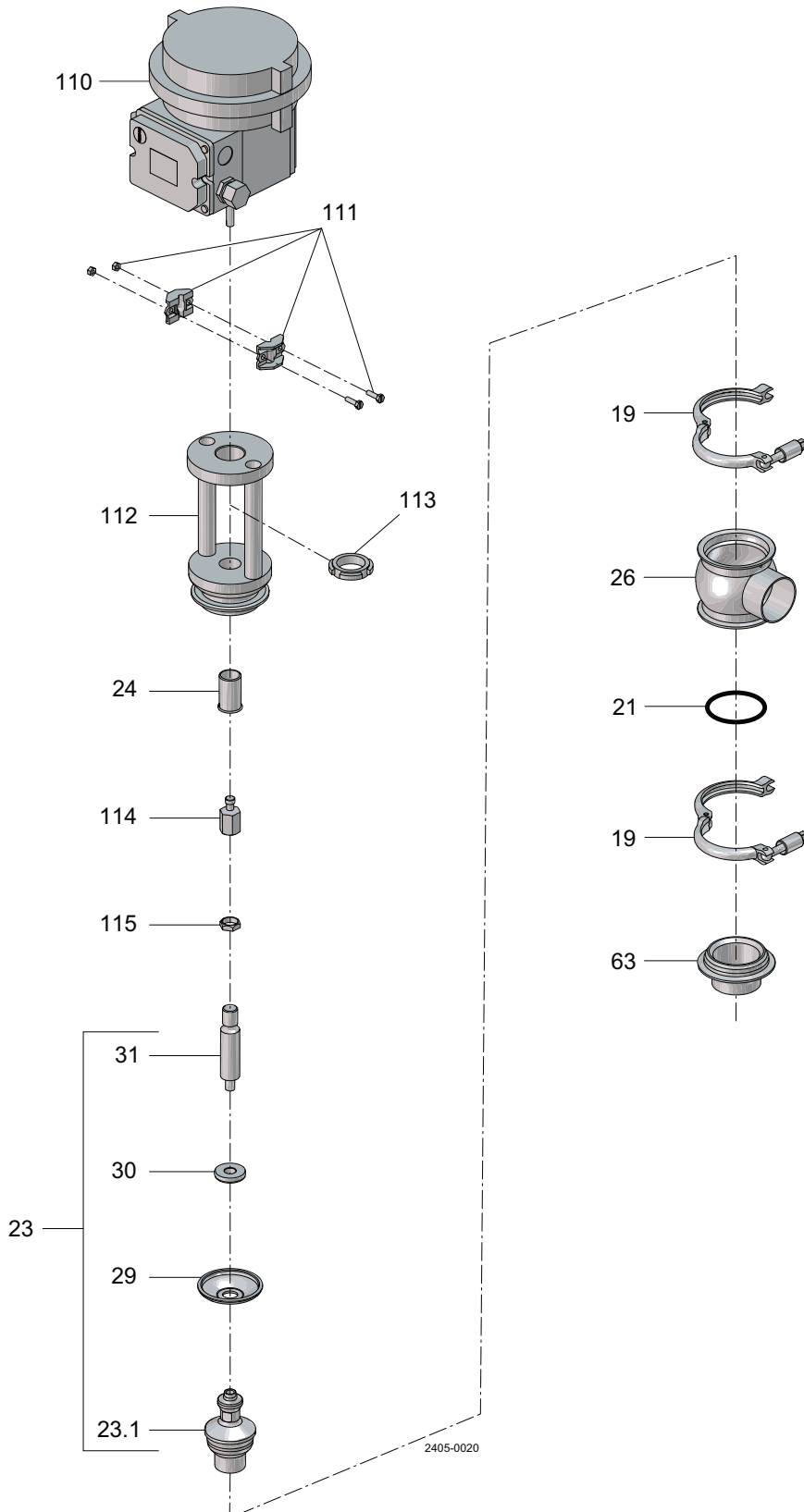

## 7 Parts list and service kits

**Always** use Alfa Laval genuine spare parts. The warranty of Alfa Laval products is dependent on the use of Alfa Laval genuine spare parts.

### Parts list

Pos.	Qty	Denomination
19	2	Clamp
21 *	1	O-ring
23	1	Plug, complete
23.1	1	Plug
26	1	Valve body
29 *	1	Diaphragm
30	1	Disc
31	1	Upper Spindel
63	1	Seat
110	1	Actuator, complete
111	1	Clamp fitting
112	1	Bonnet, complete
113	1	Striking nut
114	1	Valve plug adjuster
115	1	Nut

### Service kits

Denomination	38 mm DN40	51 mm DN50	63.5 mm DN65	76.1 mm DN80	101.6 mm DN100
* Service Kit, EPDM .....	9611929001	9611929004	9611929007	9611929010	9611929013
* Service Kit, HNBR .....	9611929002	9611929005	9611929008	9611929011	9611929014
* Service Kit, FPM .....	9611929003	9611929006	9611929009	9611929012	9611929015



#### **How to contact Alfa Laval**

Contact details for all countries are continually updated on our website.

Please visit [www.alfalaval.com](http://www.alfalaval.com) to access the information directly.

© Alfa Laval Corporate AB

This document and its contents is owned by Alfa Laval Corporate AB and protected by laws governing intellectual property and thereto related rights. It is the responsibility of the user of this document to comply with all applicable intellectual property laws. Without limiting any rights related to this document, no part of this document may be copied, reproduced or transmitted in any form or by any means (electronic, mechanical, photocopying, recording, or otherwise), or for any purpose, without the expressed permission of Alfa Laval Corporate AB. Alfa Laval Corporate AB will enforce its rights related to this document to the fullest extent of the law, including the seeking of criminal prosecution.



**CSI**

CONTACT CSI FOR MORE INFORMATION | [CSIDESIGNS.COM](http://CSIDESIGNS.COM) | [SALES@CSIDESIGNS.COM](mailto:SALES@CSIDESIGNS.COM) | 417.831.1411