

Alfa Laval LeviMag®

Levitated Magnetic Mixer

Introduction

The Alfa Laval LeviMag® is an aseptic magnetic mixer that uses a patented levitating impeller and advanced design to mix down to the last drop and maximize product yield.

Compact, energy-efficient and easy to maintain, it provides dry-running capabilities and efficient mixing at low speeds, which ensures gentle product treatment, as well as at high speeds for high-intensity mixing. This provides greater process flexibility to handle a wide range of fluid types and mixing duties.

Its open design and low-speed rotation during cleaning contribute to effective residue removal and minimize contamination risks from wear particles. All this contributes to fast return on investment and maximum product yield in tanks ranging in size between 30 litres and 40,000 litres.

It is supplied with Alfa Laval Q-doc, a comprehensive documentation package that provides full transparency of the entire supply chain.

Applications

Alfa Laval LeviMag magnetic mixer offers effective mixing for multiple processes in the dairy, food, beverage, biotechnology, pharmaceutical and other industries that have demanding requirements for sterile or aseptic storage or processing.

Benefits

- Maximum process efficiency, minimal product loss
- Optimal flow with higher efficiency and less energy consumption
- Mixing down to the last drop for maximum yield due to low agitation and dry-running capability
- Optimized Cleaning-in-Place (CIP) due to full drainability
- Minimized downtime due to ease of maintenance

Standard design

The Alfa Laval LeviMag consists of a detachable drive unit, levitating impeller unit with radial blades, seals, ceramic bearings and magnetic coupling, weld plate and connections. It is available in five sizes, with mixing speeds ranging from 10 rpm up to 800 rpm.

Working principle

An impeller with radial blades installed inside the tank rotates due to the torque from the magnetic coupling. The rotation of the impeller mixes the fluid inside the tank. The unique design of the Alfa Laval magnetic coupling ensures the levitation of the impeller at all times. This enables dry-running and complete drainability of process fluids from the tank possible. This ensures highly efficient mixing down to the last drop and, subsequently, maximum yield. It also enables the free flow of CIP liquid and steam around all parts of the mixer, thereby ensuring thorough cleaning. Impeller levitation also eliminates axial wear.



Available versions

- Impeller with male/female bearing
- Impeller complete, with drive unit
- Impeller prepared for Speed Sensor
- ATEX version (Cat. II -/2G Ex h IIC T4 -/Gb)

Accessories:

- Weld plates
- Inspection & Service tools
- Installation tools

Drive unit versions

- Painted (fan ventilated)
- Clean room finish, Sealed Surface Conversion Treatment (smooth, closed, none fan ventilated)
- Extended console for insulated tanks

Internals:

Product Wetted Surface finish:	Ra <0.8 µm Mech. Polished
Working pressure:	-1 to 7 bar(g)
Impeller diameters:	100, 150, 200, 250 & 300 mm

Weld Plate:

Size WP50:	For impeller size 100 & 150 mm
Size WP81:	For impeller size 200, 250 & 300 mm

Drive Unit:**Motor, IE4 (standard):**

Integrated Permanent Magnet Synchron Motor (IPMSM) which has to be operated with a frequency inverter for IE4 motors. The frequency converter (not Alfa Laval supply) must be ordered for the voltage available at the place of operation.

Efficiency class:	IE4
Enclosure / Motor protection:	IP66

Configuration:	Blue
Nominal Power:	1.1 kW
Nominal Voltage and frequency (from frequency converter):	Output 217 VAC, connected in delta, 70 Hz, 2100 RPM
Nominal Current:	3.59 A

Configuration:	Clean room, WP50
Nominal Power:	0.75 kW
Nominal Voltage and frequency (from frequency converter):	Output 199 VAC, connected in delta, 70 Hz, 2100 RPM
Nominal Current:	2.53 A

Configuration:	Clean room, WP81
Nominal Power:	1.1 kW
Nominal Voltage and frequency (from frequency converter):	Output 195 VAC, connected in delta, 70 Hz, 2100 RPM
Nominal Current:	3.61 A

Country Code:	All (one type covers all)
---------------	---------------------------

Motor, option Premium/CUS:

Efficiency class:	Premium
Enclosure / Motor Protection:	IP66

Configuration:	Blue, WP50
Nominal Power:	0.37 kW

Nominal Voltage and frequency (from frequency converter):	Output 265 VAC, connected in delta, 60 Hz
Nominal Current:	1.40 A

Configuration:	Blue, WP81
Nominal Power:	0.75 kW

Nominal Voltage and frequency (from frequency converter):	Output 265 VAC, connected in delta, 60 Hz
Nominal Current:	2.72 A

Country Code:	US/CA
---------------	-------

Motor, option ATEX:

Efficiency class:	IE1 (WP50), IE2 (WP81)
Enclosure / Motor Protection:	IP66

Safety class:	II2G Ex de IIC T4
Configuration:	Blue, WP50

Nominal Power:	0.25 kW
Nominal Voltage and frequency (from frequency converter):	Output 230 VAC, connected in delta, 50 Hz

Nominal Current:	1.30 A
Configuration:	Blue, WP81

Nominal Power:	0.75 kW
Nominal Voltage and frequency (from frequency converter):	Output 230 VAC, connected in delta, 50 Hz

Nominal Current:	2.94 A
Country Code:	EU + Not specific



Motor, option LV Explosion Proof Motor:

Efficiency class:	Premium
Enclosure / Motor Protection:	IP66
Safety class:	Class1 Div1 Group D
Configuration:	Blue, WP50
Nominal Power:	0.37 kW
Nominal Voltage and frequency (from frequency converter):	Output 208-230 VAC, connected in delta, 60 Hz
Nominal Current:	2.1 – 2.0 A
Configuration:	Blue, WP81
Nominal Power:	1.1 kW
Nominal Voltage and frequency (from frequency converter):	Output 230 VAC, connected in delta, 60 Hz
Nominal Current:	4.4 A
Country Code:	US/CA

Gear:

High efficiency helical bevel right angle gearbox.	
Lubricant:	Food compatible oil
Maximum mounting angle acc. to horizontal:	0° - 45°C(Different angle intervals based on configuration - Note: Motor may not point down wards)
Surface finish drive unit, standard:	Painted Blue RAL 5010
Surface finish drive unit, Clean Room option:	Sealed Surface Conversion Treatment, Smooth Body (no fan)

Console/flange:

Standard height or option for extended height for insulated tanks.	
Attachment, Size WP50:	Clamp connection
Attachment, Size WP81	Flange-bolt connection

PHYSICAL DATA**Materials:**

Impeller and Weld plate:	AISI316L (UNS S31603)
Drive Rotor, shaft and console/flange:	AISI304 (UNS S30400)
Gear motor , Painted:	C2 according to DIN 12944 (NSF/ANSI 51-2009e)
Gear motor, Clean room:	Permanent Bond Surface (nsd tupH) - compl. w. FDA Title 21 CFR 175.300
Male Bearing:	Zirconia YTZP
Female bearing:	Silicium Carbide (EN 12756)
Seals:	FEP/FKM
Gearbox oil:	USDA H1

Temperatures:

During product Mixing, media:	Max. 90°C
During CIP (max. 50 RPM):	Max. 95°C
During SIP (max. 10 RPM):	Max. 125°C
During SIP (max. 0 RPM):	Max. 150°C

Max. speed:

Impeller size 100	800 RPM (81 Hz)
Impeller size 150	480 RPM (48.5 Hz)
Impeller size 200	480 RPM (83 Hz)
Impeller size 250	230 RPM (40 Hz)
Impeller size 300	200 RPM (34.5 Hz)



Documentation:

As standard with Q-Doc including:

- Compliance with Regulation (EC) No.: 1935/2004
- Compliance with (Ex/ATEX) directive 2014/34/EU (ATEX option, II -/2G Ex h IIC T4 -/Gb)
- Compliance to the EC Regulation for GMP
- 3.1 Material Certificates acc. to EN10204 (MTR) for all wetted parts
- Compliance to FDA CFR 21 (non-metallic parts) for elastomers, ceramics and gear oil.
- TSE (Transmissible Spongiform Encephalopathy) / ADI (Animal Derivative Ingredient) Declaration
- Surface finish compliance declaration

Build up:

1. Impeller
2. Seals
3. Female Bearing
4. Male Bearing
5. Weld Plate
6. Clamp ring connection (WP50 only)
7. Flange-Bolt Connection (WP81 only)
8. Drive unit

LeviMag WP50

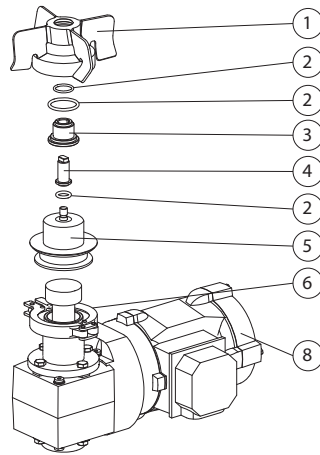

LeviMag WP81

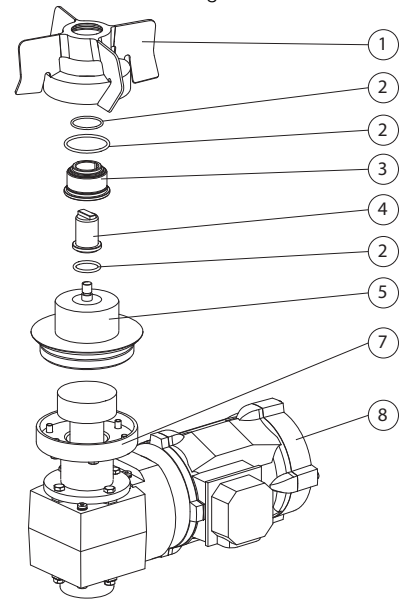

Dimensions:
LeviMag WP50

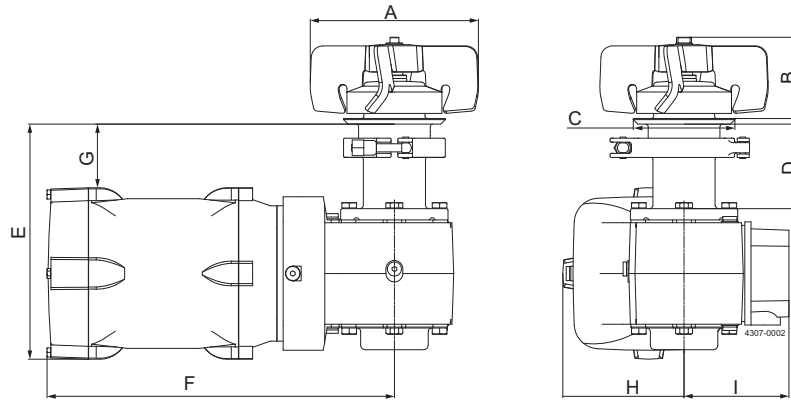

Model Configuration	Size WP50 - Ø100 impeller				Size WP50 - Ø150 impeller			
	Standard console	Extended console	Standard console	Extended console	Standard console	Extended console	Standard console	Extended console
	Height + Painted Gear Motor	Height + Painted Gear Motor	Height + Clean Room Gear Motor	Height + Clean Room Gear Motor	Height + Painted Gear Motor	Height + Painted Gear Motor	Height + Clean Room Gear Motor	Height + Clean Room Gear Motor
A	Ø100	Ø100	Ø100	Ø100	Ø150	Ø150	Ø150	Ø150
B	72	72	72	72	72	72	72	72
C	Ø90	Ø90	Ø90	Ø90	Ø90	Ø90	Ø90	Ø90
D	75	125	75	125	75	125	75	125
E IE4	215	265	209	259	215	265	209	259
F IE4	340	340	308	308	340	340	308	308
G IE4	50	100	57	107	50	100	57	107
H IE4	114	114	108	108	114	114	108	108
I IE4	111	111	93	93	111	111	93	93
E Premium/CUS	202	252	-	-	202	525	-	-
F Premium/CUS	318	318	-	-	318	318	-	-
G Premium/CUS	63	113	-	-	63	113	-	-
H Premium/CUS	105	105	-	-	105	105	-	-
I Premium/CUS	94	94	-	-	94	94	-	-
E ATEX	202	252	-	-	202	252	-	-
F ATEX	373	373	-	-	373	373	-	-
G ATEX	62	112	-	-	62	112	-	-
H ATEX	105	105	-	-	105	105	-	-
I ATEX	119	119	-	-	119	119	-	-
E LV Explosion Proof	223	273	-	-	223	273	-	-
F LV Explosion Proof	520	520	-	-	520	520	-	-
G LV Explosion Proof	45	95	-	-	45	95	-	-
H LV Explosion Proof	123	123	-	-	123	123	-	-
I LV Explosion Proof	142	142	-	-	142	142	-	-



LeviMag WP81

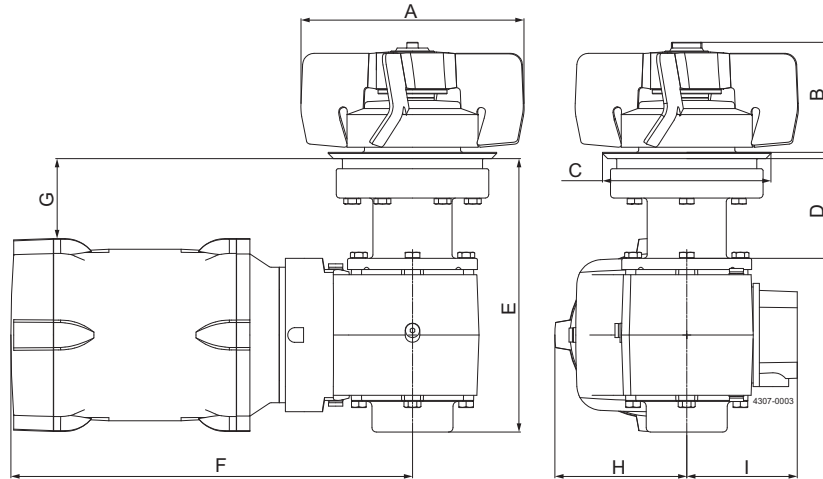

Model	Size WP81 - Ø200 impeller				Size WP81 - Ø250 impeller				Size WP81 - Ø300 impeller			
	Standard	Extended	Standard	Extended	Standard	Extended	Standard	Extended	Standard	Extended	Standard	Extended
	console	console	console	console	console	console	console	console	console	console	console	console
	Height +	Height +	Height +	Height +	Height +	Height +	Height +	Height +	Height +	Height +	Height +	Height +
Configuration	Painted Gear	Painted Gear	Clean Room	Clean Room	Painted Gear	Painted Gear	Clean Room	Clean Room	Painted Gear	Painted Gear	Clean Room	Clean Room
	Motor	Motor	Gear Motor	Gear Motor	Motor	Motor	Gear Motor	Gear Motor	Motor	Motor	Gear Motor	Gear Motor
A	Ø200	Ø200	Ø200	Ø200	Ø250	Ø250	Ø250	Ø250	Ø300	Ø300	Ø300	Ø300
B	98	98	98	98	98	98	98	98	98	98	98	98
C	Ø149	Ø149	Ø149	Ø149	Ø149	Ø149	Ø149	Ø149	Ø149	Ø149	Ø149	Ø149
D	89	139	89	139	89	139	89	139	89	139	89	139
E IE4	243	293	243	293	243	293	243	293	243	293	243	293
F IE4	354	354	357	357	354	354	357	357	354	354	357	357
G IE4	74	124	70	120	74	124	70	120	74	124	70	120
H IE4	114	114	117	117	114	114	117	117	114	114	117	117
I IE4	111	111	98	98	111	111	98	98	111	111	98	98
E Premium/CUS	243	293	-	-	243	293	-	-	243	293	-	-
F Premium/CUS	354	354	-	-	354	354	-	-	354	354	-	-
G Premium/CUS	78	128	-	-	78	128	-	-	78	128	-	-
H Premium/CUS	110	110	-	-	110	110	-	-	110	110	-	-
I Premium/CUS	112	112	-	-	112	112	-	-	112	112	-	-
E ATEX	294	344	-	-	294	344	-	-	294	344	-	-
F ATEX	418	418	-	-	418	418	-	-	418	418	-	-
G ATEX	77	127	-	-	77	127	-	-	77	127	-	-
H ATEX	110	110	-	-	110	110	-	-	110	110	-	-
I ATEX	144	144	-	-	144	144	-	-	144	144	-	-
E LV Explosion Proof	248	298	-	-	248	298	-	-	248	298	-	-
F LV Explosion Proof	534	534	-	-	534	534	-	-	534	534	-	-
G LV Explosion Proof	69	119	-	-	69	119	-	-	69	119	-	-
H LV Explosion Proof	123	123	-	-	123	123	-	-	123	123	-	-
I LV Explosion Proof	142	142	-	-	142	142	-	-	142	142	-	-



Machine Selection:

LeviMag can be sized and configured in Alfa Laval configurator.
Selection of size can also be done by use of the below selection charts.
Needed information for selection of size:

- Media Viscosity
- Tank Volume
- Tank diameter and tank bottom shape.
- Duty (see below Duty Levels)

Duty Level	Duty	Description
1	Keep media homogenous	Keeping fluids homogenous & low gradient heat transfer
2	Mild blending	Simple blending of miscible fluids & high gradient heat transfer, no specific request to mixing time, create suspension if deposit velocity is below 0.015 m/s
3	Mixing	Mixing of fluids, relative low mixing time, create suspension if deposit velocity is below 0.03 m/s
4	Powerful mixing	Dissolving solids, very low mixing time, create suspension if deposit velocity is below 0.06 m/s.

Preconditions for using the selection charts:

- Liquid height must be equal to or lower than 2½ times the tank diameter
- Specific gravity of the media must be less than or equal to 1.1
- if duty involves suspension of particles (see deposit velocity limits in the duty levels), the tank diameter D must be:

$$D \leq \sqrt[3]{\frac{V * 4}{\pi}}$$

where V is the net. Volume.

- If preconditions are not fulfilled please contact Alfa Laval Global Technical Support

How to select:

1. Select duty
2. Check preconditions
3. Go to the chart for the chosen duty
4. Read out the point for the requested tank volume (X-axis) and viscosity (Y-axis)
5. Choose the curve to the right from the point
6. If physically possible a larger impeller size can always be chosen - eg. to obtain a gentler product treatment (operating at lower speed)

Duty Level 1: Keep media homogenous
Volume vs. viscosity

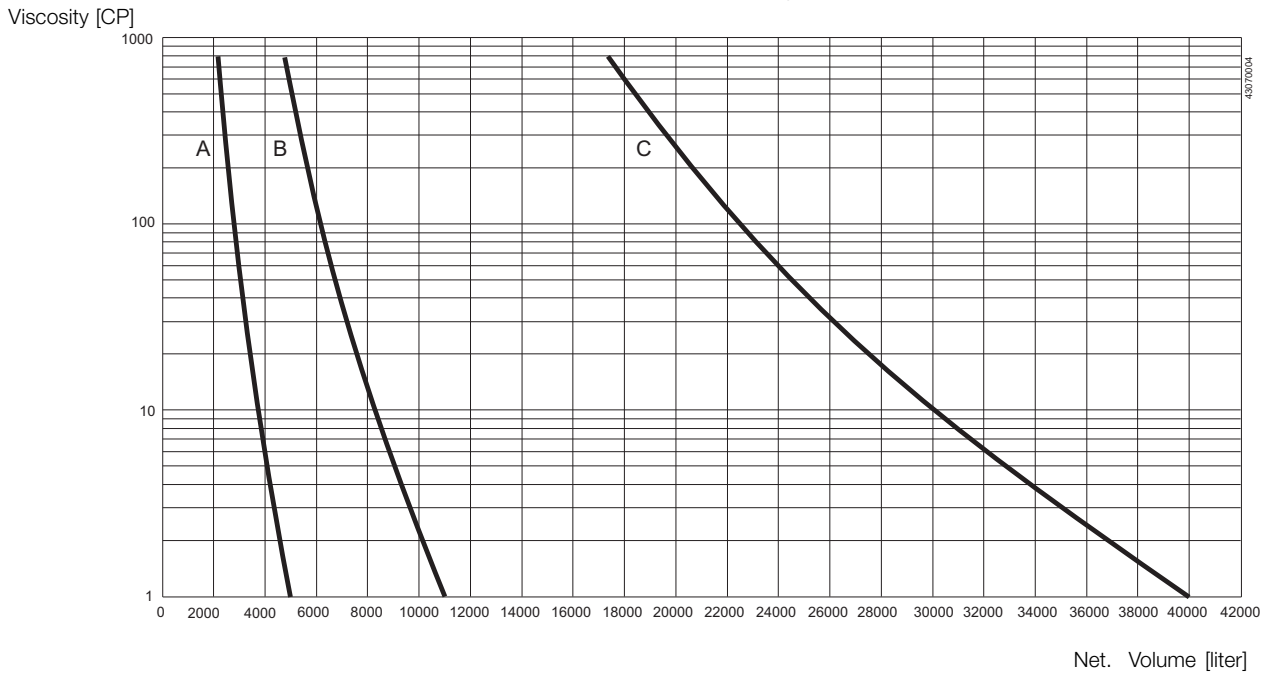

- A: LeviMag size 100 mm
- B: LeviMag size 150 mm
- C: LeviMag size 200, 250 and 300 mm

Duty Level 2: Mild blending
Volume vs. viscosity

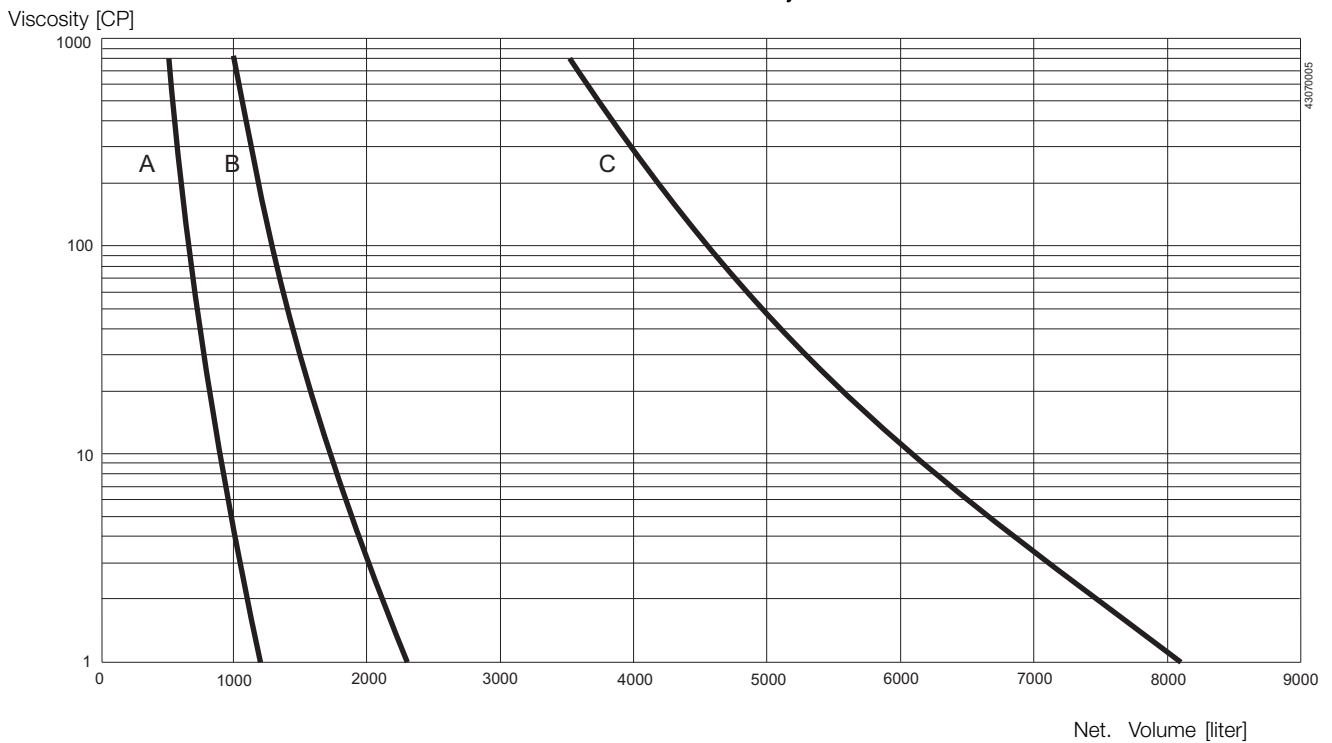

- A: LeviMag size 100 mm
- B: LeviMag size 150 mm
- C: LeviMag size 200, 250 and 300 mm



Duty Level 3: Mixing
Volume vs. viscosity

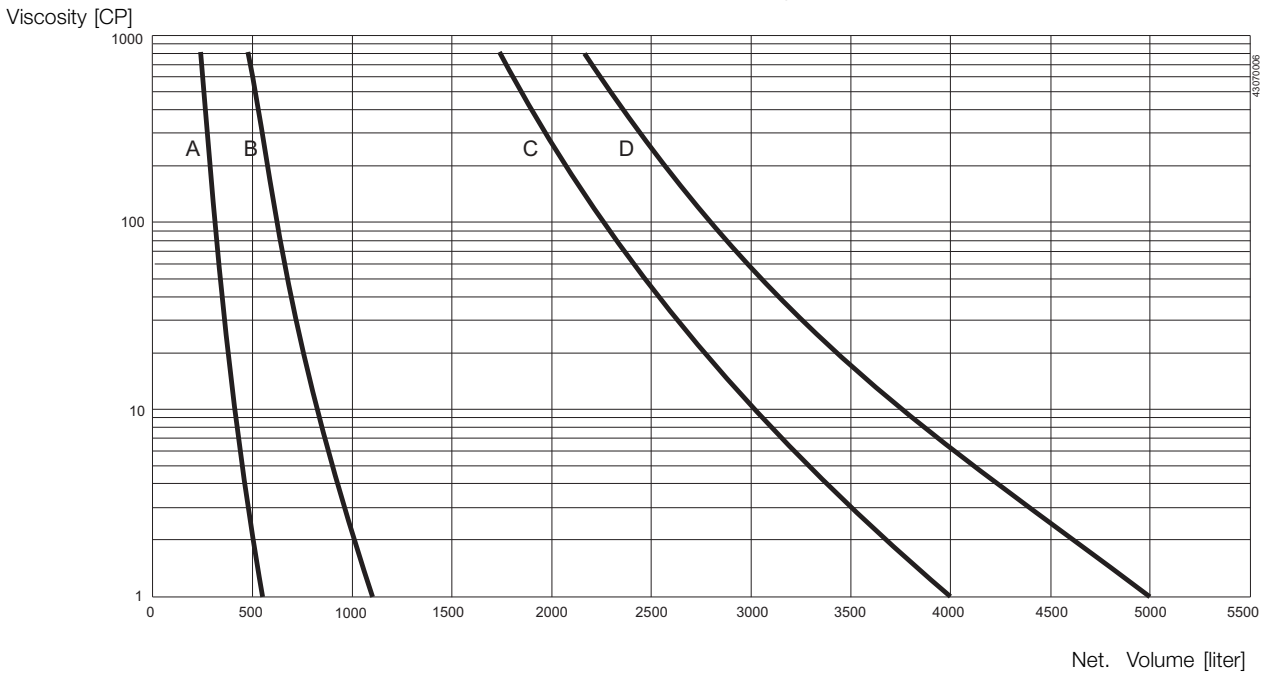

- A: LeviMag size 100 mm
- B: LeviMag size 150 mm
- C: LeviMag size 200, 250 mm
- D: LeviMag size 300 mm

Duty Level 4: Powerfull mixing
Volume vs. viscosity

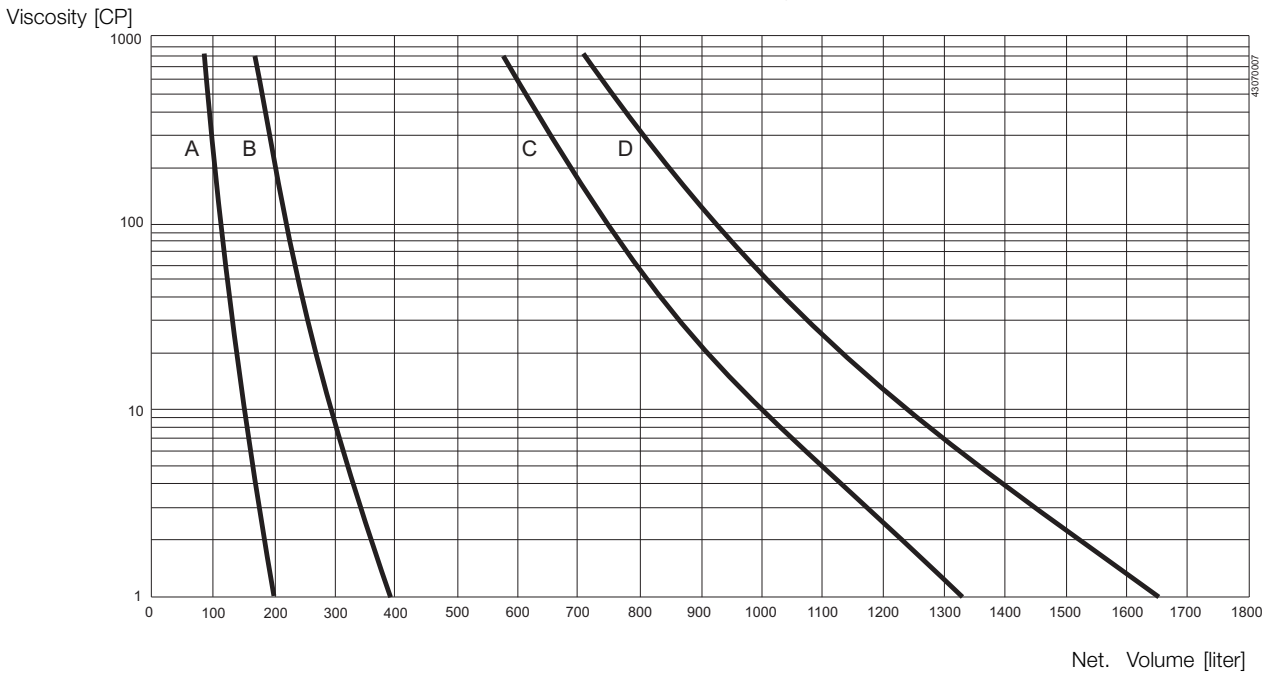

- A: LeviMag size 100 mm
- B: LeviMag size 150 mm
- C: LeviMag size 200, 250 mm
- D: LeviMag size 300 mm





CSI

CONTACT CSI FOR MORE INFORMATION | CSIDESIGNS.COM | SALES@CSIDESIGNS.COM | 417.831.1411

Alfa Laval reserves the right to change specifications without prior notification.

How to contact Alfa Laval

Contact details for all countries are continually updated on our website. Please visit www.alfalaval.com to access the information direct.



CSI

CONTACT CSI FOR MORE INFORMATION | CSIDESIGNS.COM | SALES@CSIDESIGNS.COM | 417.831.1411