



800.654.5635 • www.csidesigns.com



Alfa Laval's extensive line of Single Seat Valves meet more needs – in more industries – than any other product on the market.

Single Seat Valves

A Variety of Solutions

As the world's largest sanitary flow equipment manufacturer, Alfa Laval prides itself in providing solutions for all our customers.

No matter what market you are in – dairy, food, beverage, brewery, bio-pharm or health and beauty aids – we have the products and technology you need to process and handle your product cleanly, efficiently and economically.

Alfa Laval manufactures just about every type of sanitary single seat valve you can imagine, including:

- Automated & Manual Single Seat Valves
- Modulating Valves
- Flow Diversion Valves

The complete line of sanitary mixproof valves are featured in a separate brochure.

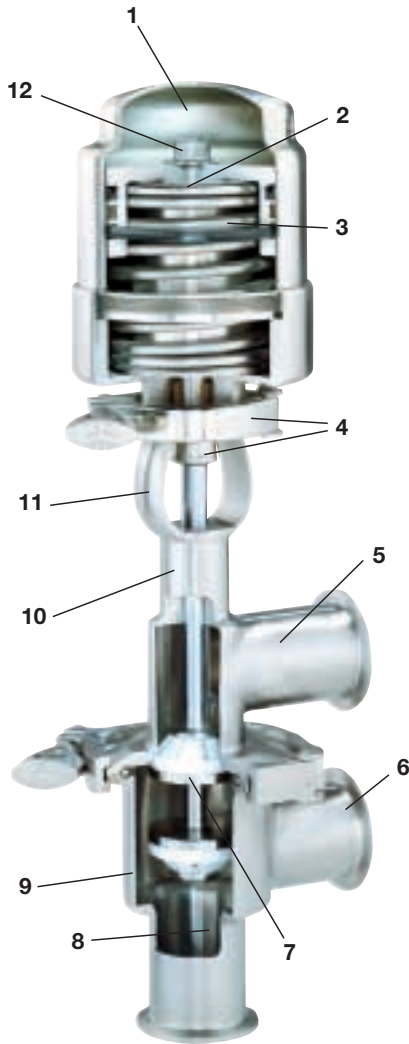

The convenience available to processors who choose the 300 Series valves can translate to enhanced process system efficiencies – and improved quality control.

300 Series

A sanitary design of proven simplicity and dependability

Our 300 Series valves remain the most dependable and easy-to-use in food, beverage, bio-technology, pharmaceutical and dairy process applications. All feature the fast, positive action of a short-stroke actuator, making them a superb choice for high-volume liquid processing applications.

Designed for top CIP performance

To meet the requirements of a Clean-In-Place valve, all 300 Series valves feature an open yoke and visible valve stem coupler. The valve stem design requires only a single o-ring. The o-ring and stem groove can be thoroughly cleaned and sanitized by oscillating the valve stem during the cleaning cycle. Other features include valve porting flush to the bottom surface of the valve body to ensure full drainage. The highly polished surface areas help eliminate the crevices and “blind” areas that can hide or trap bacteria.

Complete selection of valve styles and bodies

There is sure to be a 300 Series valve available for your application. The 300 Series is available with a choice of actuators, including normally open, normally closed or intermediate configurations. The 300 Series is also available with a choice of valve body styles.

More application versatility

Versatile design accommodates a variety of standard or special configurations. That means there is no need to purchase single-purpose, custom valve bodies. The divert valve body, for instance, permits 360° rotation for precise positioning of valve ports. And the valve/actuator combination accommodates a wider range of assembly possibilities.

Easy Assembly

All 300 Series valves can be easily assembled or disassembled using ordinary tools. A heavy-duty clamp and precision-molded bonnet gasket ensure positive alignment – even under severe operating conditions.

1. Actuators available normally open, normally closed, air-to-air or with a three-position actuator accommodating reduced flows
2. Actuator function can be easily reversed in the field
3. Chevron-type self-adjusting packaging delivers years of trouble-free operation
4. No special tools required to separate valve stem from actuator
5. Choice of standard 32Ra finish or optional 25Ra and 15Ra ID finish
6. All wetted parts feature 316L stainless steel
7. Integral stem and standard type TR seat design ensures positive seating, cleanability and long service life – Buna, fluoroelastomer or EPDM also available
8. To ensure complete drainage, valve ports are flush with bottom surface of valve body
9. All wetted surfaces are highly polished with no crevices or “blind” areas to trap bacteria
10. Single o-ring and stem groove are easily and thoroughly cleaned by oscillating valve stem during cleaning cycle
11. Open yoke design provides visual check of valve’s stem position and leak detection
12. Valve stem and valve bonnet bore are polished and hardened to reduce friction and minimize wear for longer service life

700 Series

More dependability and easy maintenance

The 700 Series valves are designed to deliver years of reliable performance. Rugged and long-lasting plastic stem bushings eliminate metal-to-metal galling. The stems are threaded to the actuator shaft, eliminating the coupling between the stem and the actuator, thereby ensuring proper alignment. And bushings at each end of the cylinder support stem also ensure perfect alignment. The 700 Series features a heavy-duty bonnet and body ferrule design that will stand up to years of pounding from hydraulic shock.

More styles and sizes for more application versatility

Two actuators (long and short) fit most 700 Series valves – including a wide selection of shut-off and divert valves. Valves are also available in sizes from 1" (25mm) to 4" (102mm) OD so you can build any size valve without increasing inventory requirements. Available normally open or normally closed, actuators can be field-reversed simply by disassembling, repositioning and reassembling.

The most advanced technology in air-actuated design

Our 700 Series valves feature the most advanced valve technology in the industry. All of our years of experience serving the process industries has resulted in a valve that delivers more confidence, more reliability and more application-matched features to enhance productivity throughout your entire process application.

1. Adaptable for control top unit (*ThinkTop*[®])
2. Coated springs designed for long life, high-holding pressures
3. Valve stem threads onto actuator stem, eliminating coupling
4. Available in Tri-Clamp, butt-weld or other process connections
5. Choice of standard 32Ra finish or optional 25Ra and 15Ra ID finish (unpolished OD option available, model 741)
6. All wetted parts feature 316L stainless steel
7. Seat styles include type "TR" replaceable or molded elastomer material types: Buna, fluoroelastomer or EPDM
8. Solid rubber body gasket for sanitary sealing of valve body to bonnet
9. Close-fitting bushings ensure stem alignment and allow ample clearance between metal surfaces to eliminate galling
10. Single clamp for easier maintenance
11. Permanently assembled actuators are reversible from normally open to normally closed by mounting end-to-end on valve yokes
12. Permanently molded rubber double lip seal on piston ensures long life
13. Clear nylon 12 plastic stem protector shields stem for added safety and visual indication of valve status

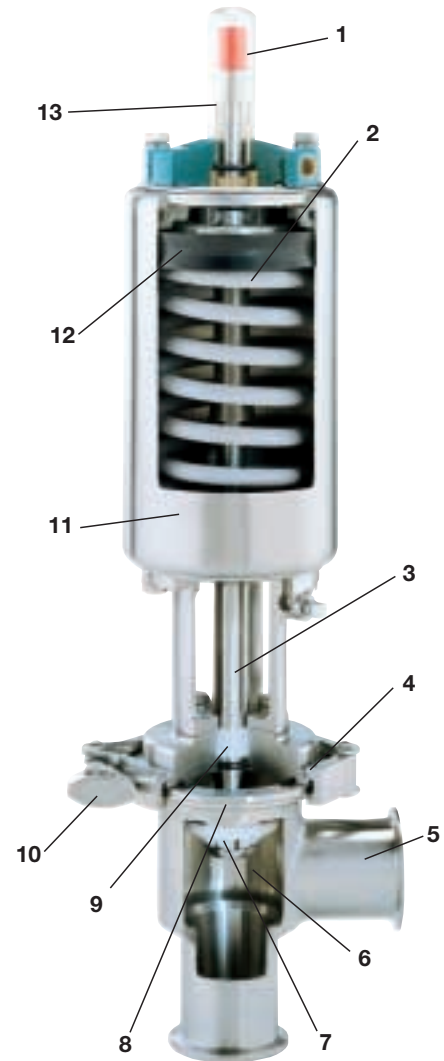

Alfa Laval's 700 Series valves feature the most advanced valve technology in the industry. The 700 Series valve delivers confidence, reliability and application – matched features to enhance productivity throughout the entire processing application.



SRC

SRC Seat Valves

Alfa Laval's sanitary remote controlled valves require only a few simple moving parts for operation. They offer an extremely reliable and hygienic design for stopping or diverting product flow in single or multi-directional systems.

Features and benefits

- Rubber lip seal wipes the stem clean during both upward and downward travel
- No o-ring or o-ring groove, so contaminants cannot migrate or collect within
- Features compact valve bodies to minimize space requirements
- Field reversible actuators (normally open and normally closed) for convenient system rebuilding
- Flat compression seat design for longer seat life
- Parts are interchangeable within the line to help reduce the burden and cost of carrying a large inventory of spare parts
- Stainless steel construction (product-wetted parts, 316L)
- Authorized to carry the 3A symbol
- Can be fitted with *ThinkTop*® control and indication unit

Options include special actuators for opening or closing against higher product pressures or for accommodating split flows.



SRC-LS



SMO



ARC



ARC-SB

SRC seats are available with a choice of Buna, fluoroelastomer or EPDM, depending on your product. Divert valve ports can be positioned in a 360° rotation.

SRC-LS

Long Stroke Actuated Valve

- Allows for higher Cv
- For high viscosity products
- For products with solids
- Used as a divert or shut-off valve
- Authorized to carry the 3A symbol

SMO

Sanitary Manually Operated Valve

- Basic design with few moving parts
- Hand crank operation allows valve to be opened gradually
- Stainless steel construction (product-wetted parts, 316L)
- Authorized to carry the 3A symbol

ARC

Aseptic Remote Controlled Valve with PTFE Diaphragm

- Designed to meet most aseptic applications
- Sterile stem sealing is ensured by PTFE/rubber diaphragm unit
- The PTFE diaphragm does not allow product residue to build-up on the product contact service
- Excellent cleanability and gentle product treatment
- The valve does not require use of steam
- Authorized to carry the 3A symbol
- Available as a shut-off or divert valve

ARC-SB

Aseptic Remote Controlled Valve with Steel Bellows

- For most aseptic applications, particularly those with high activation frequencies
- Sterile steam sealing is ensured by a specially designed valve plug with stainless steel bellows
- Stainless steel bellows provide:
 - immediate leakage indication
 - optimum hygienic qualities
 - safe sterile seal against the atmosphere
- The valve does not require the use of steam
- Authorized to carry the 3A symbol
- Available as a shut-off or divert valve

CPM-2 Constant Pressure Modulating Valves

The Alfa Laval air-actuated CPM-2 valve series is designed to maintain either constant inlet or constant outlet pressure – important for such applications as: pasteurization, separation, filling systems, filters, filtration and heat exchangers.

Inside, a diaphragm/valve plug system reacts immediately to any alteration of product pressure and changes position so that the pre-set pressure is maintained. The pre-set pressure set point is adjusted by means of a precision self-relieving regulator.

Features and Benefits of CPM-2

- Optimum body design for excellent cleanability
- Side port tangential to bottom of valve body, resulting in no sump
- Welded seat
- Radii on lower diaphragm resulting in excellent cleanability at the clamp area
- Several plug Cvs available dependent upon application
- One special plug allows very low capacities and high CIP flow
- Excellent leakage indication
- Authorized to carry the 3A symbol

Alfa Laval also offers the CPM-I-D-60 for use in higher flow stainless steel pipe systems. Used as an overflow valve, the CPM-I-D-60 maintains a constant pressure in the process line at the inlet side of the valve.



CPM-2 The CPM-O-2 regulates outlet flow by opening at decreasing product pressure and closing at increasing product pressure. The CPM-I-2 regulates inlet flow in the opposite manner.

771 Air Operated Regulating Valve



700 Tank Outlet

761 Reverse Acting Divert Valve



For more precise control of the process

For Regulating Pressure and Product Flow

Alfa Laval offers a comprehensive line of valves for applications which require precise control of product flow, pressure and temperature, in order to preserve product integrity.

371 and 771 Series Air-Operated Regulating Valve

The design of this valve is based on our 300 and 700 Series lines. However, it features a wide selection of stainless steel tapered valve stems and special actuators that deliver an outstanding degree of product control.

In fact, the tapered design results in product flow which is in direct linear response to stem movement.

Stem choices are available with varying degrees of taper to correspond with the needs of your application.

Valve positioners help achieve this control. They provide a stabilizing action in a valve's pneumatic circuit. Plus, they are engineered to maintain a predetermined valve position, regardless of other forces acting on the valve to change that position.

700 Series Tank Outlet Valve

Tank valves are engineered to accommodate a wide variety of vertical- and horizontal-mounted applications. Flush mounting helps eliminate dead space and minimize product retention. Plus, they are universally adaptable to a number of vessel applications.

The 700 Series design allows the identical switch and control options for automatic operation as the 761 valve. Outlet or inlet valves are mounted tangentially to facilitate production flow and ensure full drainage.

762 Flow Diversion Valve

The unique features of the 762 make it one of the most trusted valves in the 700 Series. Its advanced design provides reliability, convenience and high-performance for the entire life of the valve.

- Versatile Installation Options – the valve can be ordered with a left- or right-sided installation, allowing you to choose a valve that suits your current processing system
- Quick Diversions – quick exhaust on the actuator diverts product quickly, even with large flows (up to 1,000 gpm)
- Efficient Control – a single switch, per valve, reduces potential for mechanical failure. A nut on the stem triggers precise stem motion
- Precision Compression – precision gasket compression eliminates gasket recession inside the valve connection or gasket extrusion inside the valve, providing superior cleanability

Reverse acting version features:

- Drainable Body – tangential body mounts horizontally. Prevents product pooling within the valve body
- Reverse Acting Stem – closes against product flow, eliminating hydraulic shock
- Leakage Detection – patented stem-within-a-stem directs product leakage due to o-ring failure outside of the product zone
- Self-Sanitizing – horizontal mounting places o-ring stem connection in the forward flow path, constantly quenching o-rings with heated product

650-655 Series Fractional Valves

The 650-655 Series has been designed for 1/2" and 3/4" line sizes within the food, beverage, pharmaceutical, cosmetic or biotechnology processing industries. The self-draining ports and ease-of-operation make the valve ideal for processes where an uncompromising sanitary dosing environment is demanded. For example:

- Processing Equipment – stills, condensers, fermenters, heat exchangers, filters and strainers
- Make-Up and Dosing Lines – for pH and steam in biotechnology systems
- Pure Water Service – DI, RO pyrogen-free and other water treatment or processing operations
- Laboratory/Pilot Plant – low-volume research applications and small-scale development products

The wide range of styles (manual shut-off, air-actuated, relief, sample and check), together with the available surface finish and elastomer options, enable the processor to match the valve to the specific application. These fractional valves also provide long service life and are easy to maintain.



Series 650 and 655 Air-Actuated Valves



ThinkTop® has a registered design and patented sensor system.

ThinkTop® – Control and indication

For optimum valve control

ThinkTop® offers the most advanced automated control of valves in the industry. Whether you're modifying an existing plant or planning a new installation, *ThinkTop* is right for your process.

ThinkTop's registered design features the modularity and flexibility like no other control unit Alfa Laval has ever offered. In addition, *ThinkTop*:

- is self-adjusting when installed
- can be set up without dismantling or re-adjusting
- fits all air-operated sanitary valves from Alfa Laval
- features an integrated indication of seat lift
- offers the ability to integrate external signals in the top
- saves set-up parameters until re-programmed – even in case of power failure

Providing the world with processing solutions.

Alfa Laval is a leading global provider of specialized products and engineering solutions. Our equipment, systems and services are dedicated to assisting customers in optimizing the performance of their processes, time and time again. We help them heat, cool, separate and transport products such as oil, water, chemicals, beverages, foodstuff, starch and pharmaceuticals. Our worldwide organization works closely with customers in almost 100 countries to help them stay ahead.

Our U.S.-based sanitary group offers Alfa Laval and Tri-Clover fluid handling and heat transfer equipment. Since 1919, Tri-Clover has been the leading supplier of processing equipment to the sanitary flow industry in North America. Part of Alfa Laval since 1986, Tri-Clover's sales and marketing functions were consolidated within the overall Alfa Laval organization in December 2000, creating the undisputed global leader in this industry. Tri-Clover remains a key brand within Alfa Laval.



800.654.5635
www.csidesigns.com



www.alfalaval.com