



800.654.5635 • www.csdesigns.com

Low Flow Saves on Water and Chemicals

Toftejorg MicroSpinner Rotary Spray Head

PD 66393 GB1 2003-08

Application

The Toftejorg MicroSpinner is a rotary spray head that uses cleaning media to provide coverage and impact. The device represents an effective alternative to traditional static spray balls because it uses low volumes of cleaning fluid at low pressure. The double ball bearing in the Toftejorg MicroSpinner's rotating head makes the device suitable for all industrial cleaning applications, including tanks, reactors, vessels and other containers ranging from 0.05 to 1 m³ (10 - 250 US gallons), depending on dimensions and cleaning task. Assistance with optimal application positioning and other technical recommendations are available in CAD format.

Working Principle

The flow of the cleaning media causes the head of the Toftejorg MicroSpinner to rotate, and the fan-shaped jets lay out a swirling pattern throughout the tank or reactor. This generates the impact needed for the efficient removal of residual product; the cascading flow covers all internal surfaces of the vessel.

Standard Design

The Toftejorg MicroSpinner is available in Hastelloy C4. Both 1.4401 (316) and Hastelloy C4 are available in polished versions. As standard documentation, the Toftejorg MicroSpinner can be supplied with a "Declaration of Conformity" for material specifications, and 3.1.B certification can be quoted on request.

Materials

Housing, Inlet connection, Head: 1.4404 (316L), Balls: 1.4401 (316)

Technical Data

Weight:	75 g (0.2 lbs)
Lubricant:	Self-lubricating with the cleaning fluid
Working pressure:	1 - 10 bar (14.5 - 145 psi)
Recommended pressure:	1 - 5 bar (14.5 - 73 psi)
Max. working temperature:	110 °C (230 °F)
Max. ambient temperature:	180 °C (356 °F)
Spray pattern:	Cleaning pattern 340° to 350° down Max. radius 610 mm (2 ft)
Wetting pattern:	Wetting pattern 360° Max. radius 1 m (3 ft)
Min. tank opening:	25 mm diameter (DN 25)



Connection: 3/8" BSP or NPT thread, 1/4" BSP thread
Clip-on or weld-on for pipe

Ordering

Please specify desired spray pattern, required connections, material selection and type of certification required. Please also confirm the application suitability.

Options

- Downpipe assemblies with Tri-Clamp fittings and flange connections in 1.4401 (316) or Hastelloy C4
- Spray pattern of 180° and 90° down can be quoted on request

Flow Rate

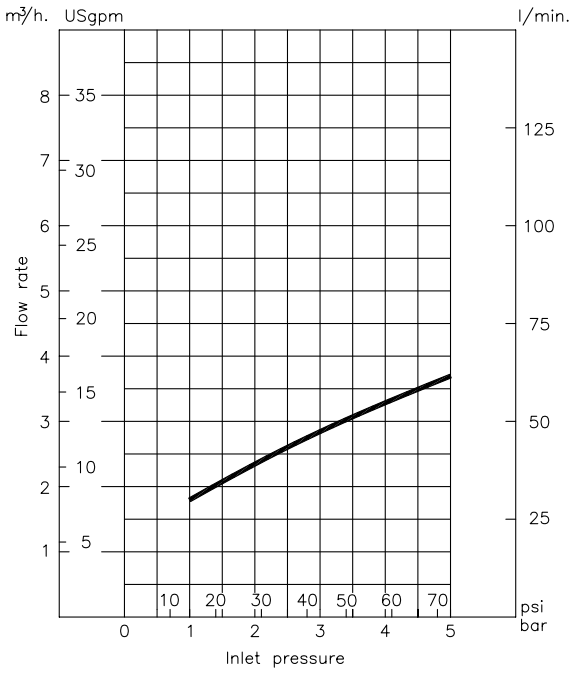

Cleaning Radius

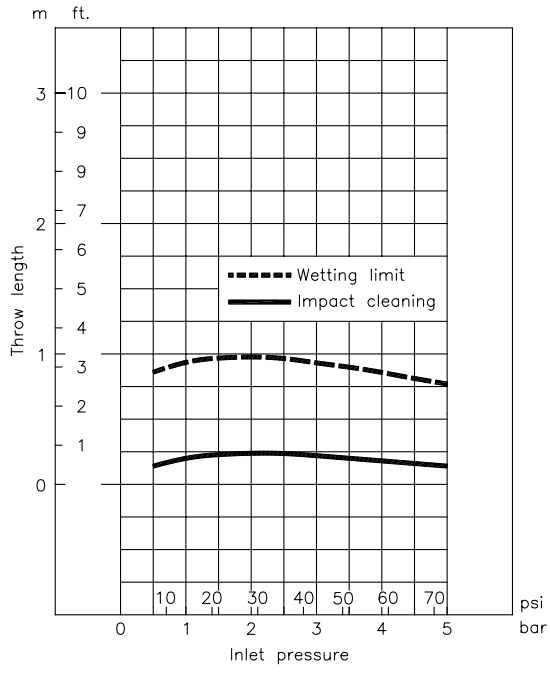

For clip-on models, the flow rate is increased by approx 0.5 m³/h.

Dimensions (mm)

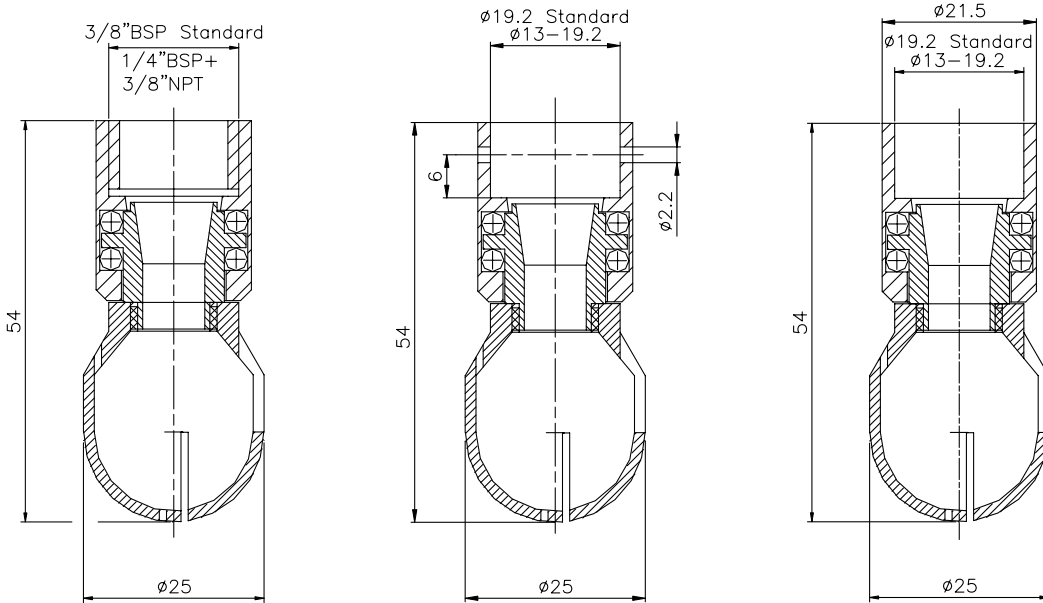

PD 66393 GB1 2003-08

The information contained herein is correct at the time of issue, but may be subject to change without prior notice.

How to contact Alfa Laval

Contact details for all countries are continually updated on our website. Please visit www.alfalaval.com or www.toftejorg.com to access the information direct.



800.654.5635
www.csidesigns.com