

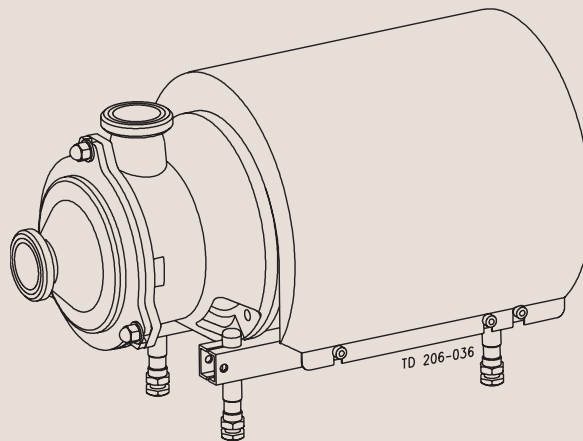

800.654.5635
www.csidesigns.com

Instruction Manual

MR-166S, -185S, -200S Liquid-Ring Pump



Declaration of Conformity

The designating company

Alfa Laval

Company Name

6000 Kolding

Address

+45 79 32 22 00

Phone No.

hereby declare that

Liquid-Ring Pump

Denomination

MR-166S, -185S, -200S

Type

Year

is in conformity with the following directives with amendments:

- Low Voltage Directive 73/23/EEC
- EMC Directive 89/336/EEC
- Machinery Directive 98/37/EC

Bjarne Søndergaard

Name

Vice President, R & D

Title

Alfa Laval

Company

B. Søndergaard

Signature

Designation

CE

Safety

- 1. Important Information 2
- 2. Warning Signs 2
- 3. Safety Precautions 3

Installation

- 1. Unpacking/Delivery 4
- 2. Installation/Pre-Use Check MR-166S 5
- 3. Installation/Pre-Use Check
MR-185S and MR-200S 6

Operation

- 1. Operation/Control 8
- 2. Fault Finding 8
- 3. Recommended Cleaning 9

Maintenance

- 1. General Maintenance 10
- 2. Dismantling of Pump/Shaft Seal MR-166S 12
- 3. Dismantling of Pump/Shaft Seal
MR-185S and MR-200S 14
- 4. Assembly of Pump/Shaft Seal MR-166S ... 16
- 5. Assembly of Pump/Shaft Seal
MR-185S and MR-200S 18

Technical data

- 1. Technical Data 20

Drawings/Parts list

- 1. Parts List 22+24+26+28
- 2. Exploded Drawing 23+27
- 3. Drawing 25+29

Safety

Unsafe practices and other important information are emphasized in this manual.

Warnings are emphasized by means of special signs.

1. Important Information

Always read the manual before using the pump!

2

- WARNING!** : Indicates that special procedures **must** be followed to avoid severe personal injury.
- CAUTION!** : Indicates that special procedures **must** be followed to avoid damage to the pump.
- NOTE!** : Indicates important information to simplify practices or to make them clearer.

2. Warning Signs



: General warning.



: Dangerous electrical voltage.



: Caustic agents.

All warnings in the manual are summarized on this page.

Pay special attention to the instructions below so that severe personal injury or damage to the pump are avoided.

3. Safety Precautions

Installation:



- : - **Always** observe the technical data (see page 20).
- **Never** stick your fingers or any tool through the adaptor or the drain hole in the pump casing when the pump is running.
- **Never** test the direction of rotation with liquid in the pump.



- : The pump **must** be electrically connected by authorized personnel (see the motor instructions).



- : **Always** disconnect the power supply before dismantling the pump.

Operation:



- : **Always** observe the technical data (see page 20).



- : **Never** touch the pump or the pipelines when pumping hot liquids or when sterilizing.



- : **Never** run the pump with both the suction side and the pressure side blocked.



- : **Never** stick your fingers or any tool through the adaptor or the drain hole in the pump casing when the pump is running.



- : **Always** handle lye and acid with great care.

Maintenance:



- : **Always** observe the technical data (see page 20).



- : **Always** disconnect the power supply when the pump is serviced.



- : - The pump must **never** be hot when serviced.
- The pump and the pipelines must **never** be pressurised when the pump is serviced.

Installation

4

*The instruction manual is part of the delivery.
Study the instructions carefully.
The pump is available in three sizes, MR-166S, MR-185S and MR-200S.*

1. Unpacking/Delivery

1

NOTE!

Alfa Laval cannot be held responsible for incorrect unpacking.

Check the delivery:

1. Complete pump, MR-166S, MR-185S or MR-200S.
2. Delivery note.
3. Instruction manual.
4. Motor instructions.
5. Test certificate, IF ORDERED!

2

Clean the inlet and the outlet from possible packing materials.

3

Inspect the pump for visible transport damage.

4

Avoid damaging the inlet and the outlet.

5

Always remove the shroud, if fitted, before lifting the pump.

Study the instructions carefully and pay special attention to the warnings!

The direction of rotation of the impeller can be checked by observing the direction of rotation of the motor fan.
- See the indication label on the pump.

2. Installation/Pre-use Check - MR-166S

1



- **Always** observe the technical data (see page 20).



- **Never** stick your fingers or any tool through the bracket or the drain hole in the pump casing when the pump is running.
The pump **must** be electrically connected by authorized personnel (see the motor instructions).

NOTE!

Alfa Laval cannot be held responsible for incorrect installation.

3

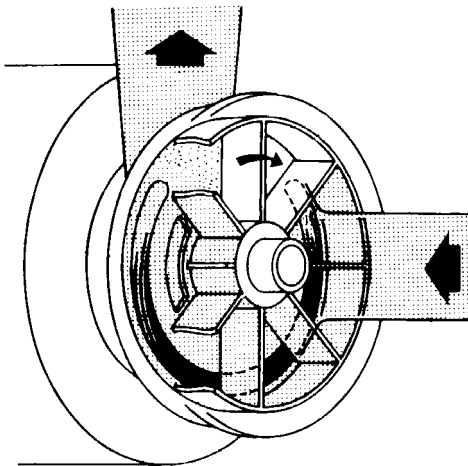

5

Risk of damage!

Avoid stressing the pump.

Pay special attention to:

- Vibrations.
- Thermal expansion of the tubes.
- Excessive welding.
- Overloading of the pipelines.

2

Ensure at least 0.5m clearance around the pump.

4

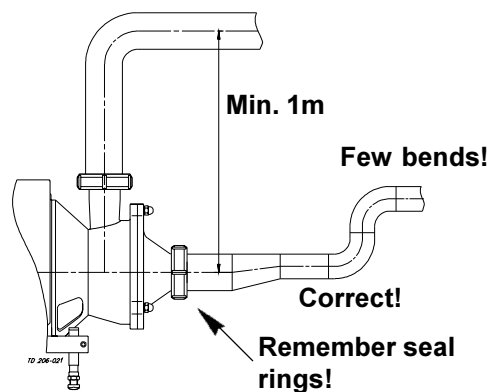

1. Ensure that the pipelines are correctly routed.
2. Ensure that connections are tight.

6



- **Never** test the direction of rotation with liquid in the pump.

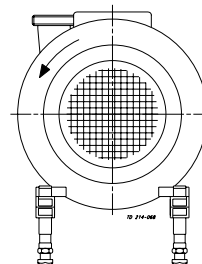

Pre-use check:

1. Start and stop the motor momentarily.
2. Ensure that the direction of rotation of the motor is **counterclockwise** as viewed from the back of the motor.

Installation

Study the instructions carefully and pay special attention to the warnings!

The direction of rotation of the impeller can be checked by observing the direction of rotation of the motor fan.
- See the indication label on the pump.

3. Installation/Pre-use Check - MR-185S and MR-200S

6

1



- **Always** observe the technical data (see page 20).
- **Never** stick your fingers or any tool through the adaptor or the drain hole in the pump casing when the pump is running.



The pump **must** be electrically connected by authorized personnel (see the motor instructions).

NOTE!

Alfa Laval cannot be held responsible for incorrect installation.

3

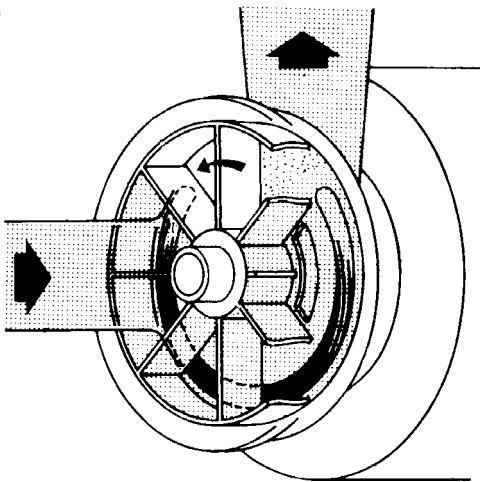

2

Ensure at least 0.5m clearance around the pump.

4

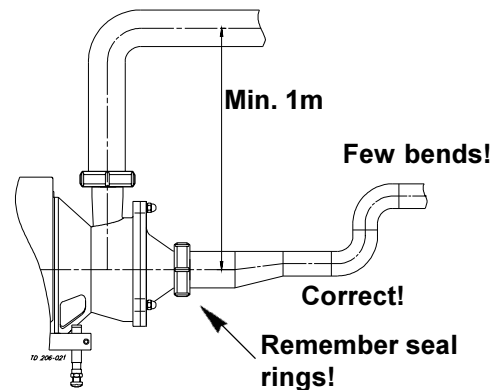

1. Ensure that pipelines are routed correctly.
2. Ensure that connections are tight.

5

Risk of damage!

Avoid stressing the pump.

Pay special attention to:

- Vibrations.
- Thermal expansion of the tubes.
- Excessive welding.
- Overloading of the pipelines.

6



Never test the direction of rotation with liquid in the pump.

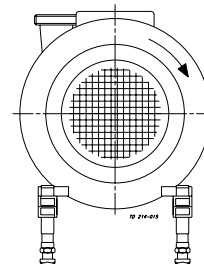

Pre-use check:

1. Start and stop the motor momentarily.
2. Ensure that the direction of rotation of the motor is **clockwise** as viewed from the back of the motor.

Study the instructions carefully and pay special attention to the warnings!

The pump is fitted with a warning label indicating correct throttling.

1. Operation/Control

1

 **Always** observe the technical data (see page 20).

NOTE!

Alfa Laval cannot be held responsible for incorrect operation/control.

2

Burning danger!

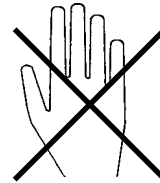

 **Never** touch the pump or the pipelines when pumping hot liquids or when sterilizing.

3

Explosion danger!

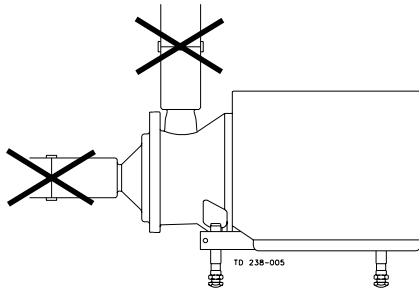

 **Never** run the pump with both the suction side and the pressure side blocked.

4

Rotating parts!

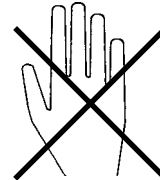

 **Never** stick your fingers or any tool through the adaptor or the drain hole in the pump casing when the pump is running.

5

CAUTION!

- The shaft seal must not run dry.
- Never throttle the inlet side.

6

Control:

Reduce the capacity by means of:

- Throttling the pressure side of the pump.
- Speed control of the motor.

Pay attention to possible faults.

Study the instructions carefully.

2. Fault Finding

NOTE!

Study the maintenance instructions carefully before replacing worn parts. - See page 10!

8

Problem	Cause/result	Repair
Leaking shaft seal	<ul style="list-style-type: none">- Dry run (See page 7)- Incorrect rubber grade- Abrasive particles in the liquid	Replace: All wearing parts (See page 13) <ul style="list-style-type: none">- Select a different rubber grade- Select stationary and rotating seal ring in Silicon Carbide/ Silicon Carbide (only MR-185S/ MR200S)
Leaking seals	Incorrect rubber grade	Select a different rubber grade

The pump is designed for cleaning in place (CIP).
CIP = Cleaning In Place.

Study the instructions carefully and pay special attention to the warnings!
NaOH = Caustic Soda.
HNO₃ = Nitric acid.

3. Recommended Cleaning

1

Caustic danger!



Always use rubber gloves!



Always use protective goggles!



Always handle lye and acid with great care.

3

Examples of cleaning agents:

Use clean water, free from chlorides.

- 1% by weight NaOH at 70°C.

1 kg NaOH	+	100 l water	= Cleaning agent.
-----------	---	-------------	-------------------

2.2 l 33%NaOH	+	100 l water	= Cleaning agent.
---------------	---	-------------	-------------------

- 0.5% by weight HNO₃ at 70°C.

0.7 l 53% HNO ₃	+	100 l water	= Cleaning agent.
----------------------------	---	-------------	-------------------

5

Always!

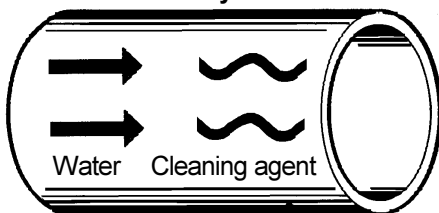

Always rinse well with clean water after the cleaning.

2

Burning danger!

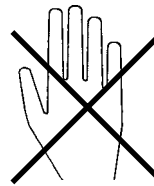

Never touch the pump or the pipelines when sterilizing.

4

1. Avoid excessive concentration of the cleaning agent

⇒ **Dose gradually!**

2. Adjust the cleaning flow to the process

Milk sterilization/viscous liquids

⇒ **Increase the cleaning flow!**

6

NOTE!

The cleaning agents must be stored/discharged in accordance with current rules/directives.

Maintenance

10

Maintain the pump carefully.
Study the instructions carefully and pay special attention to the warnings!

Always keep spare shaft seals and rubber seals in stock.
See separate motor instructions.

1. General Maintenance

1

 **Always** observe the technical data (see page 20).

 **Always** disconnect the power supply when the pump is serviced.

NOTE!

All scrap must be stored/discharged in accordance with current rules/directives.

3

Atmospheric pressure required!

 The pump and the pipelines must **never** be pressurised when the pump is serviced.

5

CAUTION!

Fit the electrical connections correctly if they have been removed from the motor during service (see pre-use check on pages 5-6).

Pay special attention to the warnings!

2

Burning danger!



 The pump must **never** be hot when serviced.

4

CAUTION

Always ensure that the impeller rotates smoothly after service.

1. Rotate impeller (11) through the inlet.
2. Ensure that the impeller does not contact pump casing (9) or casing cover (10).
3. Adjust the impeller position if necessary (see page 17 for MR-166S and page 19 for MR-185S and MR-200S).

Ordering spare parts

- Contact the Sales Department.
- Order from the Spare Parts List.

**Recommended spare parts:
Service kits (see Spare Parts List).**

Maintain the pump carefully.
 Study the instructions carefully.
 Always keep spare shaft seals and rubber seals in stock.

See separate motor instructions.
 Check the pump for smooth operation after service.

1. General Maintenance

	Shaft seal	Rubber seals	Motor bearings
Preventive maintenance	Replace after 12 months: (one-shift) Complete shaft seal	Replace when replacing the shaft seal	
Maintenance after leakage (leakage normally starts slowly)	Replace at the end of the day: Complete shaft seal	Replace when replacing the shaft seal	
Planned maintenance	<ul style="list-style-type: none"> - Regular inspection for leakage and smooth operation - Keep a record of the pump - Use the statistics for planning of inspections Replace after leakage: Complete shaft seal	Replace when replacing the shaft seal	Yearly inspection is recommended <ul style="list-style-type: none"> - Replace complete bearing if worn - Ensure that the bearing is axially locked (See motor instructions)
Lubrication	Before fitting Lubricate the O-rings with silicone grease or silicone oil (not the sealing surfaces)	Before fitting Silicone grease or silicone oil	None The bearings are permanently lubricated

Maintenance

12

Study the instructions carefully.
The items refer to the drawings and the parts list on pages 22-29.

Handle scrap correctly.

2. Dismantling of Pump/Removing the Shaft Seal (2 and 4-8 ✱) MR-166S

1

Remove screws (43), shroud (5) and distance sleeve (44).

2

Remove cap nuts (14), washers (15a) and casing cover (10).

3

Remove O-ring (30) from stationary seal ring (29).
Remove O-ring (8) from pump casing (9).

4

1. Remove impeller nut **clockwise** (13), (counterhold stub shaft (3)).
2. Remove impeller (11) from the stub shaft.

5

Remove key (12) from stub shaft (3) by using a pair of tongs.

6

Turn stationary seal ring (29) **counterclockwise** and remove it from pump casing (9) (use the tool supplied).

7

Remove O-ring (30) from stationary seal ring (29).

8

Remove rotating seal ring (28), O-ring (27), washer (26), spacer ring (25) and spring (24) from stub shaft (3).

NOTE!

If necessary, place a screwdriver through the hole in pump casing (9) and push the seal parts out.

Study the instructions carefully.
The items refer to the drawings and the parts list on pages 22-29.

Handle scrap correctly.

2. Dismantling of Pump/Removing the Shaft Seal (2 and 4-8 ✱) MR-166S

9

1. Remove screws (45) and washers (46).
2. Remove bracket (2) together with pump casing (9).

11

Remove thrower (21) from stub shaft (3).

10

1. Remove screws (40) and washers (41).
2. Remove pump casing (9) from bracket (2).

12

1. Loosen screws (4).
 2. Remove stub shaft (3).
-

Maintenance

14

Study the instructions carefully.
The items refer to the drawings and the parts list on pages 22-29.

Handle scrap correctly.

3. Dismantling of Pump/Removing the Shaft Seal (2 and 4-8 ✱) MR-185S and MR-200S

1

2 ✱

Remove screws (34), shroud (31) and distance sleeve (42).

Remove cap nuts (14), washers (15a) and casing cover (10).

3

4 ✱

Remove O-ring (8) from pump casing (9).

1. Remove impeller nut (13), (counterhold stub shaft (3)).
2. Remove impeller (11) from the stub shaft.

5 ✱

6 ✱

Remove key (12) from stub shaft (3) by using a pair of tongs.

Turn stationary seal ring (28) **clockwise** and remove it from pump casing (9) (use the tool supplied).

7 ✱

8 ✱

Remove O-ring (29) from stationary seal ring (28).

Remove rotating seal ring (27), spring (25) and O-ring (26) from stub shaft (3).

NOTE!

If necessary, place a screwdriver through the hole in pump casing (a) and push the seal parts out.

Study the instructions carefully.
The items refer to the drawings and the parts list on pages 22-29.

Handle scrap correctly.

3. Dismantling of Pump/Removing the Shaft Seal (2 and 4-8 ✱) MR-185S and MR-200S

9

1. Remove screws (6) and washers (7).
2. Remove adaptor (2) together with pump casing (9).

11

Remove thrower (24) from stub shaft (3).

13

Remove screws (5), washer (5a) and compression rings (4a+b) from stub shaft (3).

10

1. Remove screws (16) and washers (17).
2. Remove pump casing (9) from adaptor (2).

12

1. Loosen screws (5).
 2. Remove stub shaft (3) together with compression rings (4a+b).
-



Maintenance

Study the instructions carefully.
The items refer to the drawings and the parts list on pages 22-29.

Lubricate the rubber seals before fitting them.

4. Assembly of Pump/Fitting the Shaft Seal (11-14 ✱) MR-166S

1

1. Fit stub shaft (3) on the motor shaft.
2. Check the clearance between the end of the stub shaft and the motor flange (10-20 mm).

2

1. Tighten screws (4) lightly and evenly.
2. Ensure that the stub shaft (3) can be moved on the motor shaft.

3

1. Fit pump casing (9) on bracket (2).
2. Fit washers (41) and screws (40).
3. Tighten the screws.

4

1. Fit bracket (2) on the motor.
2. Fit washers (46) and screws (45).
3. Tighten the screws.

5

1. Fit impeller (11) on stub shaft (3).
2. Fit impeller nut **counterclockwise** (13) on the shaft and tighten lightly.

6

Ensure that the clearance between impeller (11) and pump casing (9) is 0.2-0.3 mm (tap gently with a plastic hammer).

7

Remove impeller (11), pump casing (9) and bracket (2) without moving stub shaft (3) on the motor shaft.

8

Torque tighten screws (4) evenly to 18 Nm.

Study the instructions carefully.
The items refer to the drawings and the parts list on pages 22-29.

Lubricate the rubber seals before fitting them.

4. Assembly of Pump/Fitting the Shaft Seal (11-14 *) MR-166S

9

1. Fit thrower (21) on stub shaft (3).
2. Fit bracket (2) together with pump casing (9) on the motor.
3. Fit washers (46) and screws (45).

11



1. Fit O-ring (30) on stationary seal ring (29).
2. Fit the seal ring in pump casing (9), turn it **clockwise** and tighten (use the tool supplied).

13



1. Fit O-ring (8) in pump casing (9).
 2. Fit casing cover (10).
 3. Fit washers (15a) and cap nuts (14).
 4. Tighten the cap nuts firmly.
 5. Ensure that impeller (11) rotates smoothly (see page 10).
- Note!** Pay special attention to warnings.

10

CAUTION!

Ensure that the notch in the seal ring is opposite the driving pin on thrower (21).

12



1. Place key (12) in the groove of stub shaft (3)
2. Fit impeller (11) on the shaft.
3. Fit and tighten impeller nut (13) **counter-clockwise** on the shaft.
4. Check that the clearance between the impeller and the pump casing (9) is 0.2 - 0.3 mm (adjust if necessary).

14



1. Fit shroud (5)
2. Fit distance sleeve (44) and screws (43).

Study the instructions carefully.
The items refer to the drawings and the parts list on pages 22-29.

Lubricate the rubber seals before fitting them.

5. Assembly of Pump/Fitting the Shaft Seal (11-14 ✱) MR-185S and MR-200S

1

Fit compression rings (4a+b), screws (5) and washer (5a) correctly on stub shaft (3).

3

1. Tighten screws (5) lightly and evenly.
2. Ensure that stub shaft (3) can be moved on the motor shaft.

5

1. Fit adaptor (2) on the motor.
2. Fit washers (7) and screws (6).
3. Tighten the screws.

7

Ensure that the clearance between impeller (11) and pump casing (9) is 0.15-0.20 mm (knock gently with a plastic hammer).

2

1. Fit stub shaft (3) on the motor shaft.
2. Check the clearance between the end of the stub shaft and the motor flange (10-20 mm).

4

1. Fit pump casing (9) on adaptor (2).
2. Fit washers (17) and screws (16).
3. Tighten the screws.

6

1. Fit impeller (11) on stub shaft (3).
2. Fit impeller nut (13) on the shaft and tighten lightly.

8

Remove impeller (11), pump casing (9) and adaptor (2) without moving stub shaft (3) on the motor shaft.

Study the instructions carefully.
The items refer to the drawings and the parts list on pages 22-29.

Lubricate the rubber seals before fitting them.

5. Assembly of Pump/Fitting the Shaft Seal (11-14 ✱) MR-185S and MR-200S

9

Torque tighten screws (5) evenly to 15 Nm (counterhold stub shaft (3)).

10

1. Fit thrower (24) on stub shaft (3).
2. Fit adaptor (2) together with pump casing (9) on the motor.
3. Fit washers (7) and screws (6).

11 ✱

1. Lubricate O-ring (26) and push it on stub shaft (3) and position it correctly.
2. Place spring (25) on rotating seal ring (27).
3. Push the seal ring over the O-ring as far as possible against the shoulder.

12 ✱

1. Fit O-ring (29) on stationary seal ring (28).
2. Fit the seal ring in pump casing (9), turn **counterclockwise** and tighten (use the tool supplied).

13 ✱

1. Place key (12) in the groove of stub shaft (3).
2. Fit impeller (11) and impeller nut (13) on the shaft.
3. Tighten the nut.

14 ✱

1. Fit O-ring (8) in pump casing (9).
2. Fit casing cover (10).
3. Fit washers (15a) and cap nuts (14).

15

1. Fit shroud (31).
2. Fit distance sleeve (42), washers (33) and screws (34).

Technical Data

It is important to observe the technical data during installation, operation and maintenance.

Inform the personnel about the technical data.

1. Technical Data

Data

Max. inlet pressure	400 kPa (4 bar)
Temperature range	-10° C to +140° C (EPDM)

Materials

Product wetted steel parts	AISI 316L
Other steel parts	AISI 304
Adaptor	Cast iron, zinc sprayed and coated with two-component laquer
Product wetted seals	EPDM (standard)
Alternative seals	Nitrile (NBR) and flourinated rubber (FPM)
Finish	Semi bright

Shaft seal

Seal type	Mechanical single seal
Material, stationary seal ring	AISI 329 (standard) or AISI 329 with sealing surface of Silicon Carbide*
Material, rotating seal ring	Carbon (standard) or Silicon Carbide*
Material, O-rings	EPDM (standard)
Alternative material, O-rings	Nitrile (NBR) and flourinated rubber (FPM)

Motor

Standard foot-flanged motor acc. to IEC metric standard
4 pol = 1500/1800 rpm. at 50/60 Hz
IP55 (with drain holes with labyrinth plug), insulation class F

Voltage and frequency	(3~, 50 Hz, 380-420V Δ /660-690VY 3~, 60 Hz, 440-480V Δ)
-----------------------------	---

Motor sizes (kW), 50 Hz	2.2 (MR-166S)
Motor sizes (kW), 60 Hz	2.5 (MR-166S)
Motor sizes (kW), 50 Hz	5.5 (MR-185S)
	7.5 (MR-200S)
	11 (MR-200S)
Motor sizes (kW), 60 Hz	6.3 (MR-185S)
	8.6 (MR-200S)
	12.5 (MR-200S)

* Only MR-185S and MR-200S.



Drawing/Parts List

The drawing and the parts list include all items of the pump.

The items are identical with the items in the Spare Parts List.

When ordering spare parts, please use the Spare Parts List!

Parts List MR-166S

22

Pos.	Qty.	Denomination
1	1	Motor 2.2 kW 220-240V
1		Motor 2.2 kW 380-420V
2	1	Bracket
3	1	Shaft
4	2	Screw
5	1	Shroud complete
5a	1	Edge list (included in pos.5)
6a	1	Support bar, right
6b	1	Support bar, left
8Δ	1	O-ring, EPDM (Standard)
	1	O-ring, NBR
	1	O-ring, FPM
9	1	Pump casing with sanitary fittings. Connections 51 mm ISO male SMS DIN ISO clamp BS
10	1	Casing cover with sanitary fittings. Connection 51 mm ISO male SMS DIN ISO clamp BS
11	1	Impeller
12	1	Key
13	1	Nut
14	3	Cap nut
15	3	Stud bolt
15a	3	Washer
18	4	Leg
19	4	Screw
20	4	Nut
21	1	Thrower
22	4	Nut
23	4	Screw
23a	4	Washer
24Δ	1	Spring
25Δ	1	Spacer ring
26Δ	1	Washer
27Δ	1	O-ring
28Δ	1	Rotating seal ring
29Δ	1	Stationary seal ring
30Δ	1	O-ring
40	2	Screw
41	2	Washer
43	4	Screw
44	4	Distance sleeve
45	4	Screw
46	4	Washer
49	4	Spring washer

Δ : Service kit - EPDM, NBR, FPM
(See Spare Parts list)

The drawing includes all items of the pump.
They are identical with the items in the Spare Parts List.

Exploded Drawing - MR166S

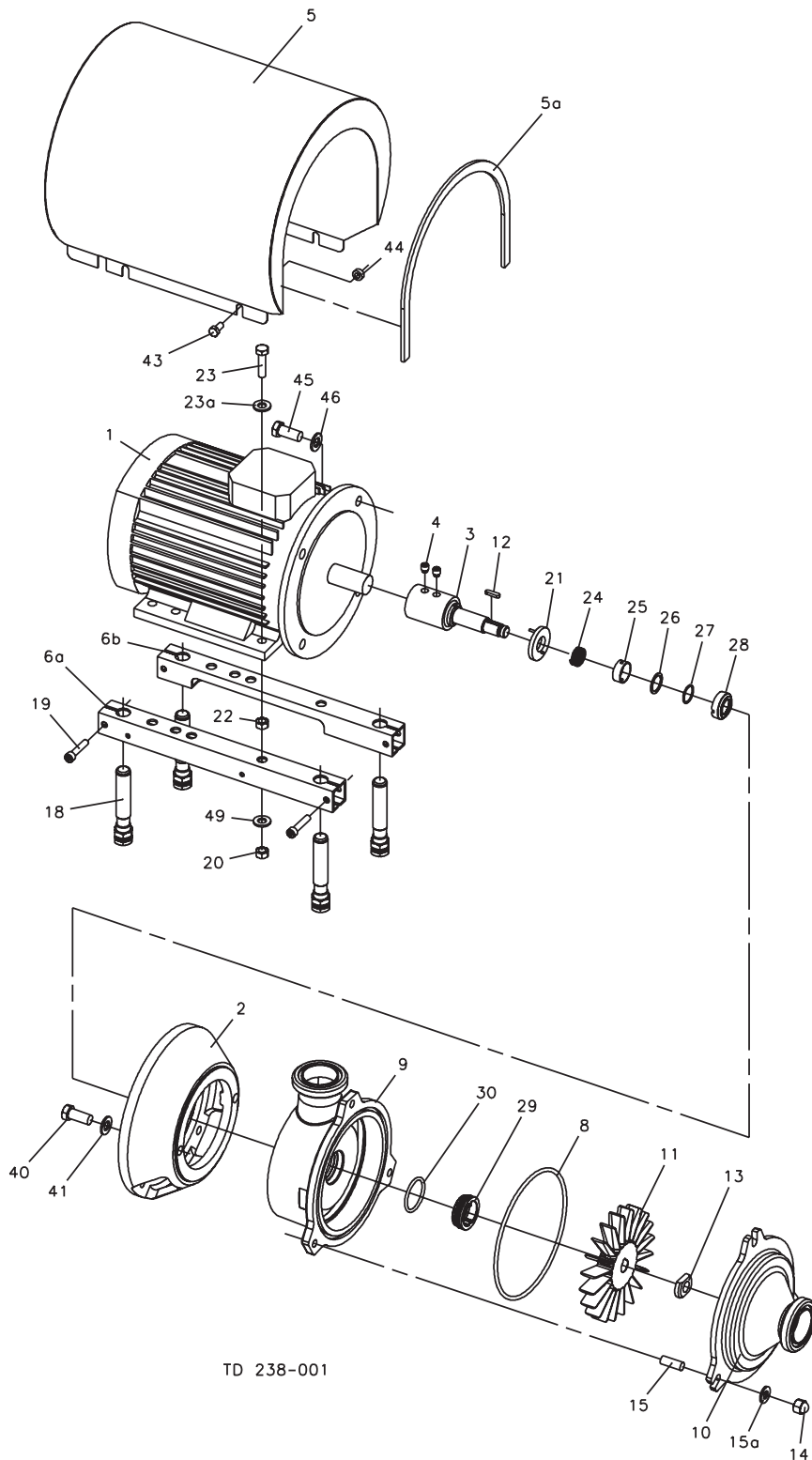

TD 238-001

Drawing/Parts List

The drawing and the parts list include all items of the pump.

The items are identical with the items in the Spare Parts List.
When ordering spare parts, please use the Spare Parts List!

Parts List MR-166S

24

Pos.	Qty.	Denomination
1	1	Motor 2.2 kW 220-240V
	1	Motor 2.2 kW 380-420V
2	1	Bracket
3	1	Shaft
4	2	Screw
5	1	Shroud complete
5a	1	Edge list (included in pos.5)
6a	1	Support bar, right
6b	1	Support bar, left
8Δ	1	O-ring, EPDM (Standard)
	1	O-ring, NBR
	1	O-ring, FPM
9	1	Pump casing with sanitary fittings. Connections 51 mm ISO male SMS DIN ISO clamp BS
10	1	Casing cover with sanitary fittings. Connection 51 mm ISO male SMS DIN ISO clamp BS
11	1	Impeller
12	1	Key
13	1	Nut
14	3	Cap nut
15	3	Stud bolt
15a	3	Washer
18	4	Leg
19	4	Screw
20	4	Nut
21	1	Thrower
22	4	Nut
23	4	Screw
23a	4	Washer
24Δ	1	Spring
25Δ	1	Spacer ring
26Δ	1	Washer
27Δ	1	O-ring
28Δ	1	Rotating seal ring
29Δ	1	Stationary seal ring
30Δ	1	O-ring
40	2	Screw
41	2	Washer
43	4	Screw
44	4	Distance sleeve
45	4	Screw
46	4	Washer
49	4	Spring washer

Δ : Service kit - EPDM, NBR, FPM
(See Spare Parts list)

The items refer to the parts list on the opposite part of the page.

Drawings - MR166S

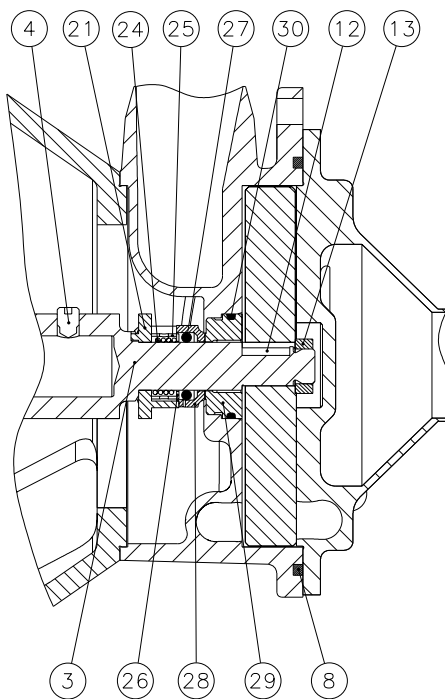
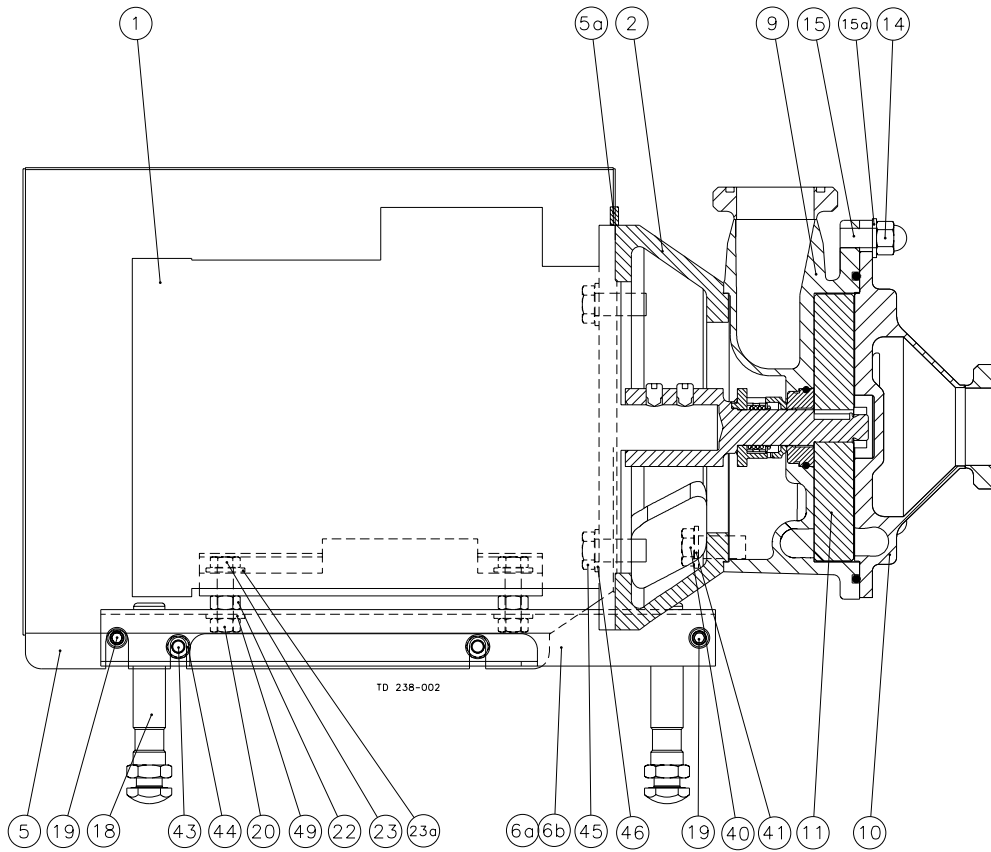

TD 238-003

Drawing/Parts list

The drawing and the parts list include all items of the pump.

The items are identical with the items in the Spare Parts List.

When ordering spare parts, please use the Spare Parts List!

Parts list MR-185S, -200S

26

Item	Qty.	Denomination
1	1	Motor
2	1	Bracket
3	1	Shaft
4a	1	Compression ring
4b	1	Compression ring
5	6	Screw
5a	6	Washer
6	4	Screw
7	4	Washer
8Δ	1	O-ring
9	1	Pump casing
10	1	Casing cover
11	1	Impeller
12	1	Key
13	1	Impeller nut
14	3	Cap nut
14a	1	Handle
15	3	Screw
15a	3	Washer
16	2	Screw
17	2	Washer
18	1	Support bar
19	1	Support bar
20	4	Pump leg
21	4	Screw
22	4	Nut
23	4	Screw
23a	4	Washer
24	1	Thrower
25Δ	1	Spring
26Δ	1	O-ring
27Δ	1	Rotating seal ring
28Δ	1	Stationary seal ring
29Δ	1	O-ring
30	4	Spring washer
31	1	Shroud
34	4	Screw
35	1	Edge list
42	4	Distance sleeve

Δ : Service kit - EPDM, NBR, FPM
(See Spare Parts list)

The drawing includes all items of the pump.
They are identical with the items in the Spare Parts List.

Exploded drawing - MR186S, - 200S

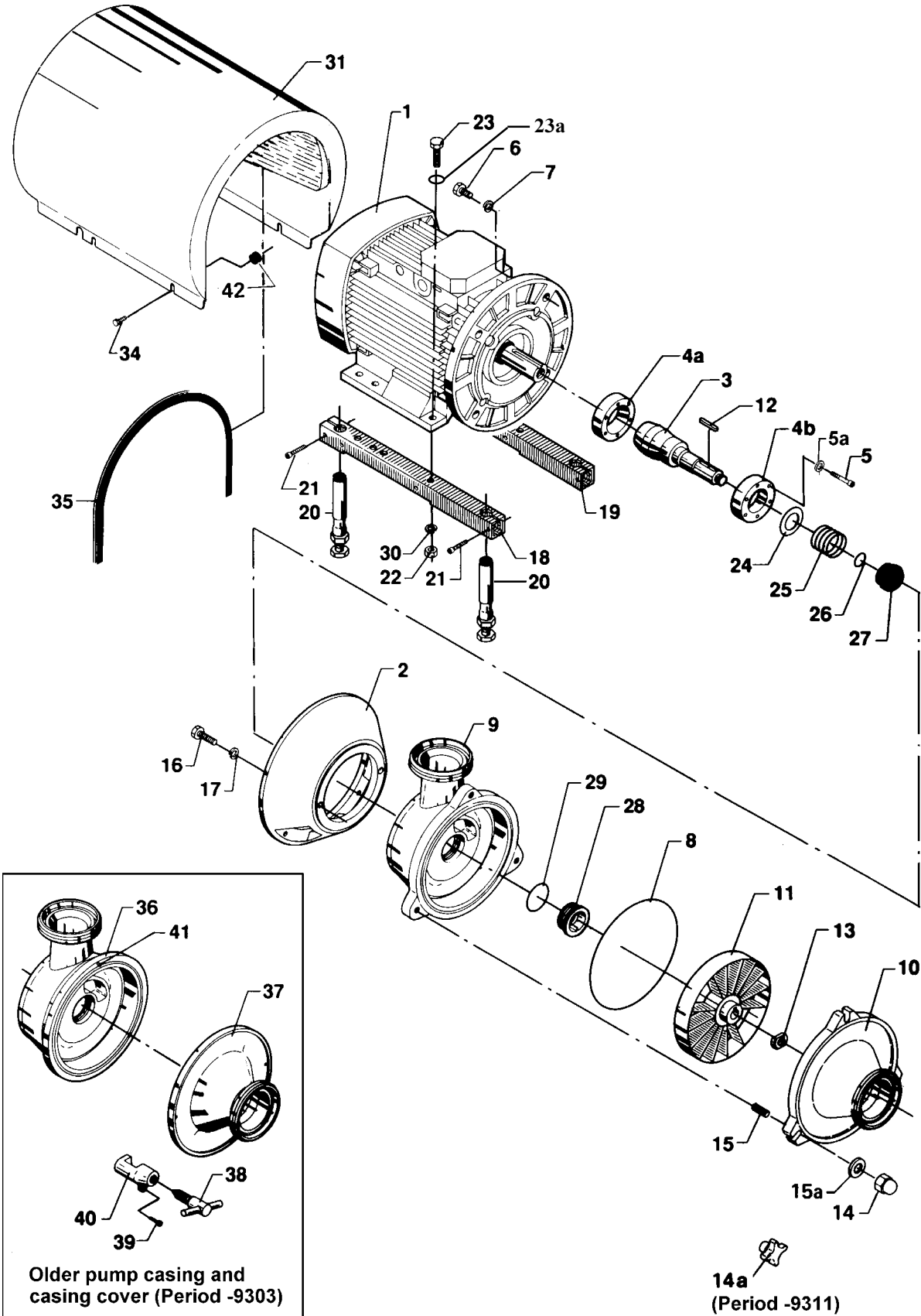

Drawing/Parts list

The drawing and the parts list include all items of the pump.

The items are identical with the items in the Spare Parts List.
When ordering spare parts, please use the Spare Parts List!

Parts list MR-185S, -200S

28

Item	Qty.	Denomination
1	1	Motor
2	1	Bracket
3	1	Shaft
4a	1	Compression ring
4b	1	Compression ring
5	6	Screw
5a	6	Washer
6	4	Screw
7	4	Washer
8 Δ	1	O-ring
9	1	Pump casing
10	1	Casing cover
11	1	Impeller
12	1	Key
13	1	Impeller nut
14	3	Cap nut
14a	1	Handle
15	3	Stud bolt
15a	3	Washer
16	2	Screw
17	2	Washer
18	1	Support bar
19	1	Support bar
20	4	Pump leg
21	4	Screw
22	4	Nut
23	4	Screw
23a	4	Washer
24	1	Thrower
25 Δ	1	Spring
26 Δ	1	O-ring
27 Δ	1	Rotating seal ring
28 Δ	1	Stationary seal ring
29 Δ	1	O-ring
30	4	Spring washer
31	1	Shroud
34	4	Screw
35	1	Edge list
42	4	Distance sleeve

Δ : Service kit - EPDM, NBR, FPM
(See Spare Parts list)

The items refer to the parts list on the previous page.

Drawings - MR185S, - 200S

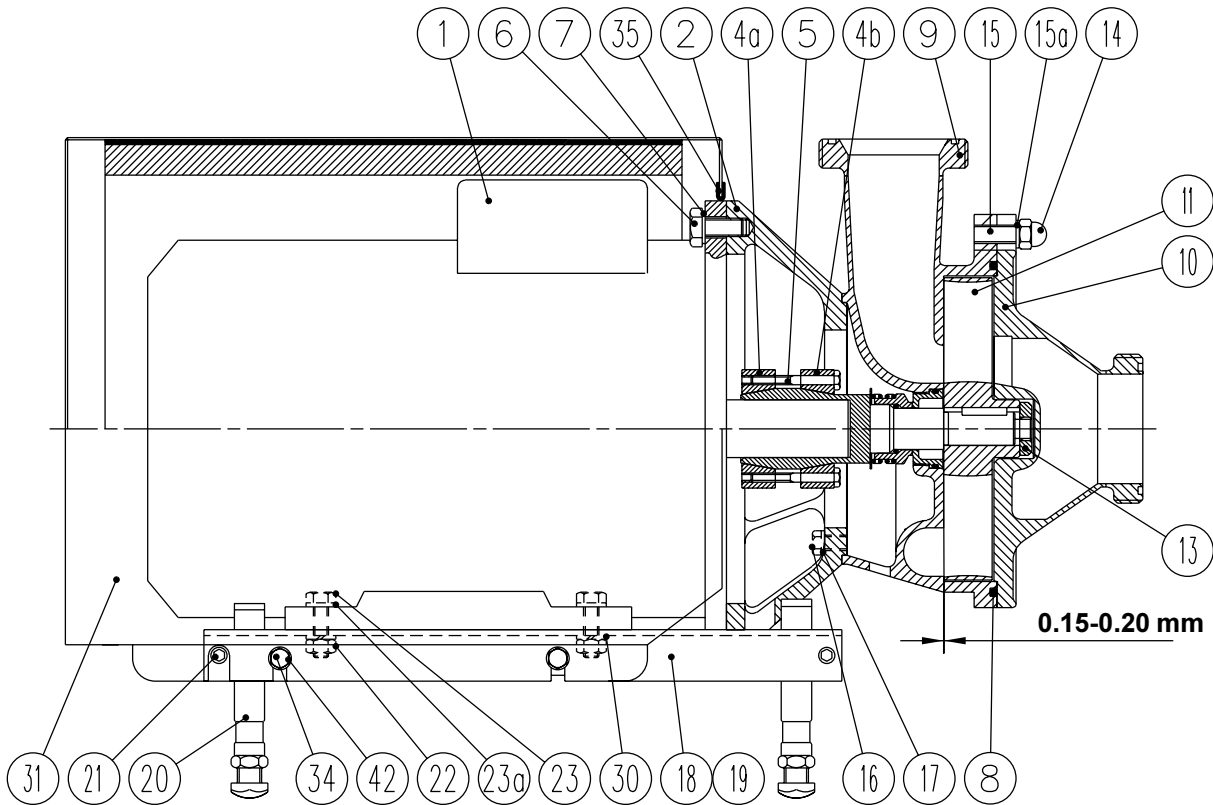

TD 206-020/3

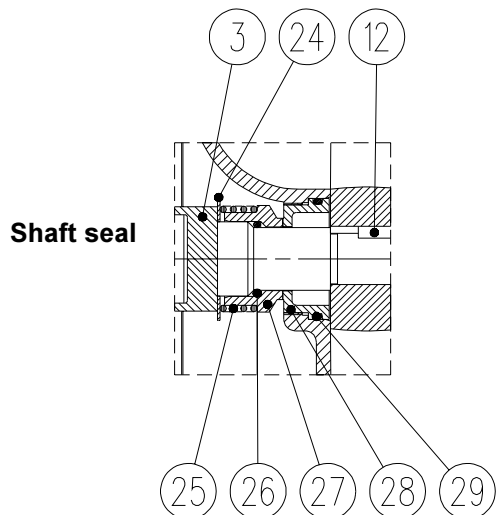

How to contact Alfa Laval

Contact details for all countries are continually updated on our website. Please visit www.alfalaval.com to access the information direct.



800.654.5635
www.csidesigns.com
