

Advanced
Tank Cleaning Systems
for the Food Industry



800.654.5635
www.csidesigns.com



ENVIRONMENTALLY PREFERRED
FAST CLEANING AT LOW COST
GUARANTEED QUALITY ASSURANCE



Toftejorg

In an industry in which HACCP (Hazard Analysis Critical Control Point) routines are necessary, Toftejorg has succeeded in raising standards of tank cleaning to such a degree that food producers can now be provided with considerably higher levels of quality assurance. The range of advanced Toftejorg rotary cleaning devices enables the food industry to clean its entire range of tanks, whilst attaining a rapid return on its investment.

Illustrated below are some examples of our customers' tanks before and after a Toftejorg cleaning process.



Tank, dirty



Tank, dirty



Tank, clean



Tank, clean

The food industry encompasses a wide range of products and a correspondingly wide range of applications for Toftejorg's cleaning technology. The photographs show just a few examples of the benefits we can offer by improving quality and at the same time reducing cleaning costs.

Advantages for the Food Industry

The application of Toftejorg rotary spray heads provides:

- Guaranteed standards of quality assurance through the rapid cleaning of food processing tanks
- Improved productivity due to a more efficient cleaning process, giving operators time to carry out other duties whilst Toftejorg equipment automatically cleans the tank
- A reduced investment in CIP installation and operating costs, since Toftejorg equipment requires minimal amounts of cleaning fluids and attains a higher degree of detergent utilization.

Design Validation

Toftejorg proprietary TRAX tank cleaning simulation software ensures the accurate evaluation, selection and testing of the correct cleaning head before our CAD-generated installation drawings are finalized.

TRAX Simulations



First Cycle

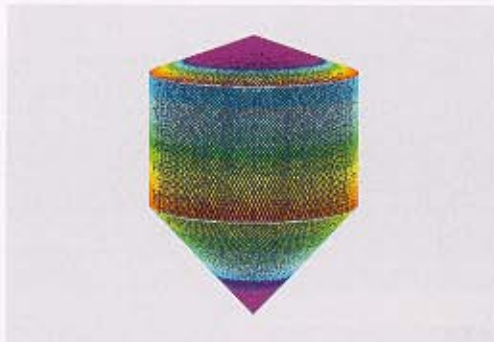

Full Pattern

CAD Installation Drawings

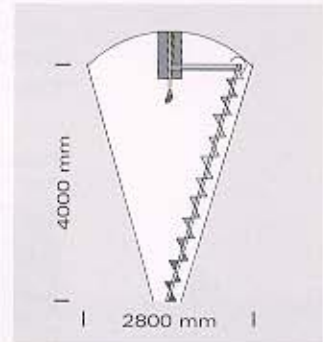

Mixer Tank

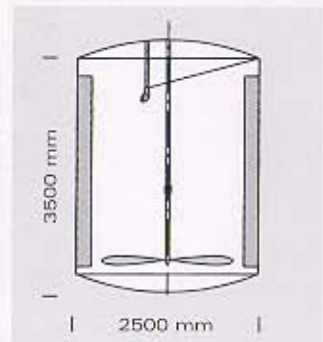

Process Vessel

This design validation policy ensures that the final system achieves optimum operating standards.

Validation of Cleaning Standards

With the Toftejorg rotary jethead indexed 360° cleaning pattern, the analysis of rinse waters, using rapid microbiological techniques such as bioluminescence, ensures accurate and representative results.

Together with the inclusion of the Rotacheck System, by which the rotary jethead movement is electronically monitored, it becomes possible for customers to obtain complete validation of tank cleaning standards.



Rotacheck Sensor

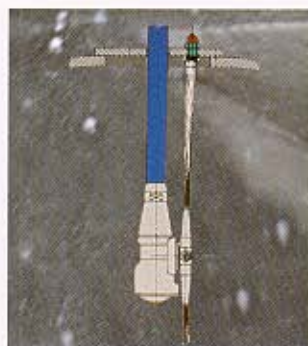

Rotacheck installation



Rotacheck in operation

Quality Standards

Specific Toftejorg cleaning heads have obtained several independent approvals. These include the TJ 20G shown below, which is EHEDG-tested (European Hygiene Equipment Design Group) for cleaning and sterilization ability, as well as the Midget, which is USDA-certified (United States Department of Agriculture).

Both products have attained widespread acceptance as a result of these approvals within the relevant food sectors. In addition, all Toftejorg cleaning systems are produced in compliance with ISO 9001 International Quality Standards.

Rotary Spray Heads

Sani Midget in operation



Rotary Jet Heads

TJ 20G in operation



Rotary Jet Heads
TZ-74 in operation

Information

For further information, please ask your local Toftejorg sales office or representative for a detailed proposal on how you can use Toftejorg equipment to improve your tank cleaning operations.



800.654.5635
www.csidesigns.com

Toftejorg



TANK CLEANING SYSTEMS

Toftejorg Inc.

2614 East Beltway Eight
Pasadena, Texas 77503
USA
Phone 281 487 7851
Fax 281 487 7937
www.toftejorg.com