



The Industry Standard

761/741 Seat Valve

PD 66365 US1 2001-10

Application

This air-operated seat valve features the positive action of either a short-stroke or long-stroke actuator. The 761/741 valve is ideal for high volume, sanitary liquid processing applications. It's heavy-duty construction and precision-molded bonnet gaskets ensure positive alignment under severe operating conditions. The 761/741 valve has a sanitary and flexible design allowing it to be used in a wide range of applications, e.g. as a stop valve with two or three ports or as divert valve with three to five ports.

Working principle

The valve is remote-controlled by means of compressed air. It has few and simple moveable parts which results in a very reliable valve.

Standard design

The 761/741 Series valves are designed to deliver years of reliable performance. Rugged and long-lasting plastic stem bushings eliminate metal-to-metal galling. The stems are threaded to the actuator shaft, eliminating the coupling between the stem and the actuator, thereby ensuring proper alignment. The valve stem design requires only a single o-ring seal. And bushings at each end of the actuator cylinder support stem also ensure perfect alignment. The 761/741 series features a heavy-duty bonnet and body ferrule design that will stand up to years of pounding from hydraulic shock. Standard 32Ra finish on the ID (unpolished OD option available for the 741 model).

Other valves in the same basic design:

- Air operated seat valve, type 361.
- Sanitary Remote controlled valve, type SRC.
- Aseptic Remote controlled valve, type ARC.
- Sanitary Long Stroke valve, type SRC-LS.
- Sanitary Manual valve, type SMO.
- Sanitary Manual valve, type SRC-BC.
- Sanitary Manual valve, type SMO-R, SMO-RA.



Fig. 1. 761 Seat valve with 10 body.

Valve body combinations

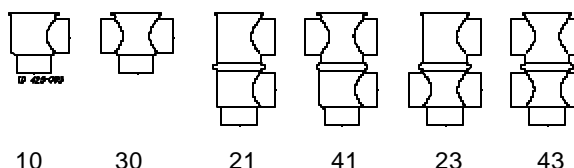

Pressure drop/capacity diagrams

761 Short-Stroke Divert Valve

Body Styles 21, 23, 41 & 43.

Flow Pattern: B to A (Solid Curve), B to C (Broken Curve)

In some cases, with low-viscosity liquids, the pressure drop in the long-stroke valve may actually be greater than the short-stroke valves.

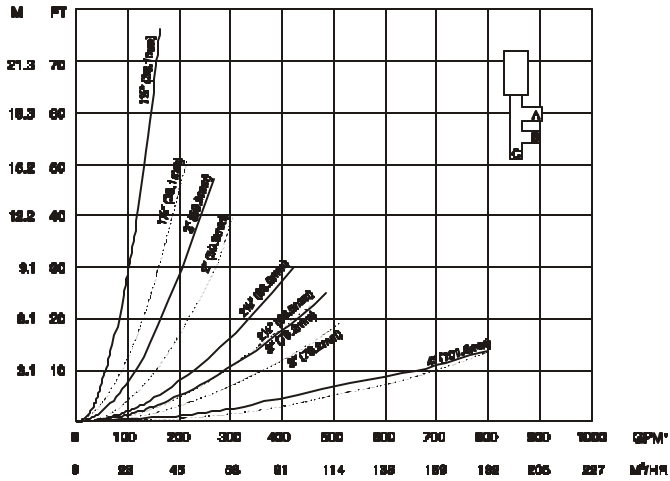

761 Short-Stroke Shut-Off Valve

Body Styles 10 & 30.

Flow Pattern: B to A (Solid Curve), A to B (Broken Curve)- Crossbodies Only

In some cases, with low-viscosity liquids, the pressure drop in the long-stroke valve may actually be greater than the short-stroke valve.

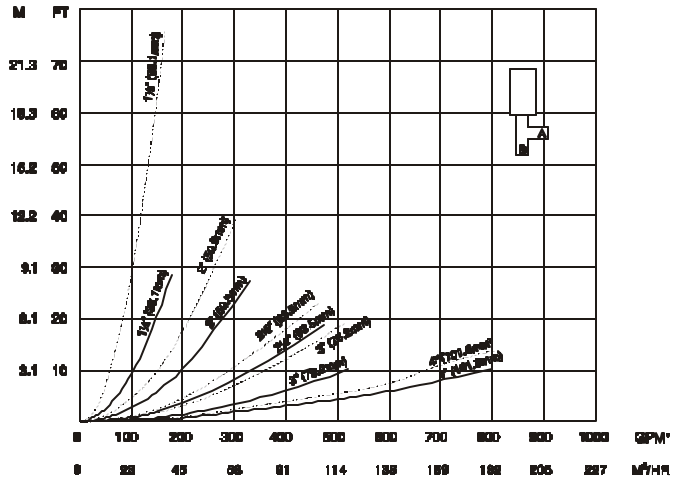

761 Long-Stroke Divert Valve

Body Styles 21, 23, 41 & 43.

Flow Pattern: B to A (Solid Curve), B to C (Broken Curve)

In some cases, with low viscosity liquids, the pressure drop in the long-stroke valve may actually be greater than the short-stroke valves.

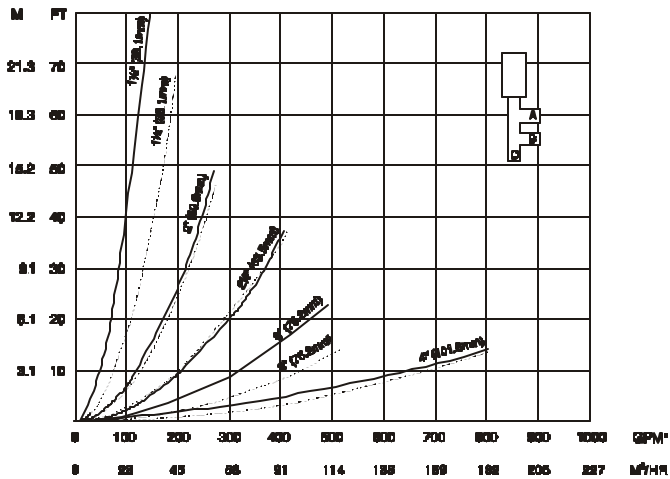

761 Long-Stroke Shut-Off Valves

Body Styles 10 & 30.

Flow Pattern: B to A (Solid Curve), A to B (Broken Curve) - Crossbodies Only

In some cases, with low-viscosity liquids, the pressure drop in the long-stroke valve may actually be greater than the short-stroke valves.

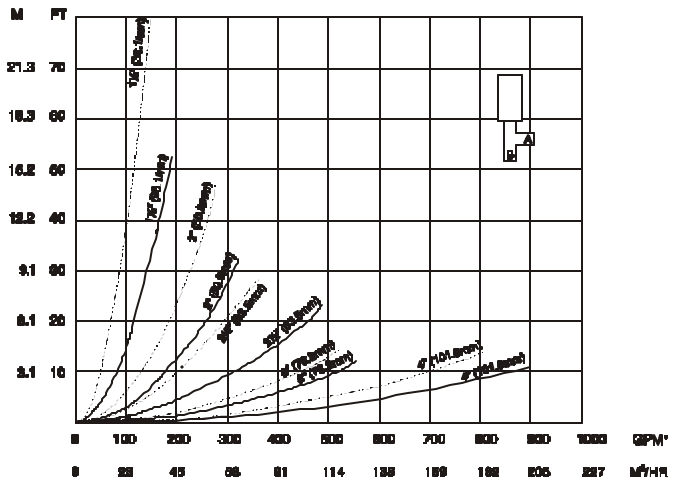

Dimensions

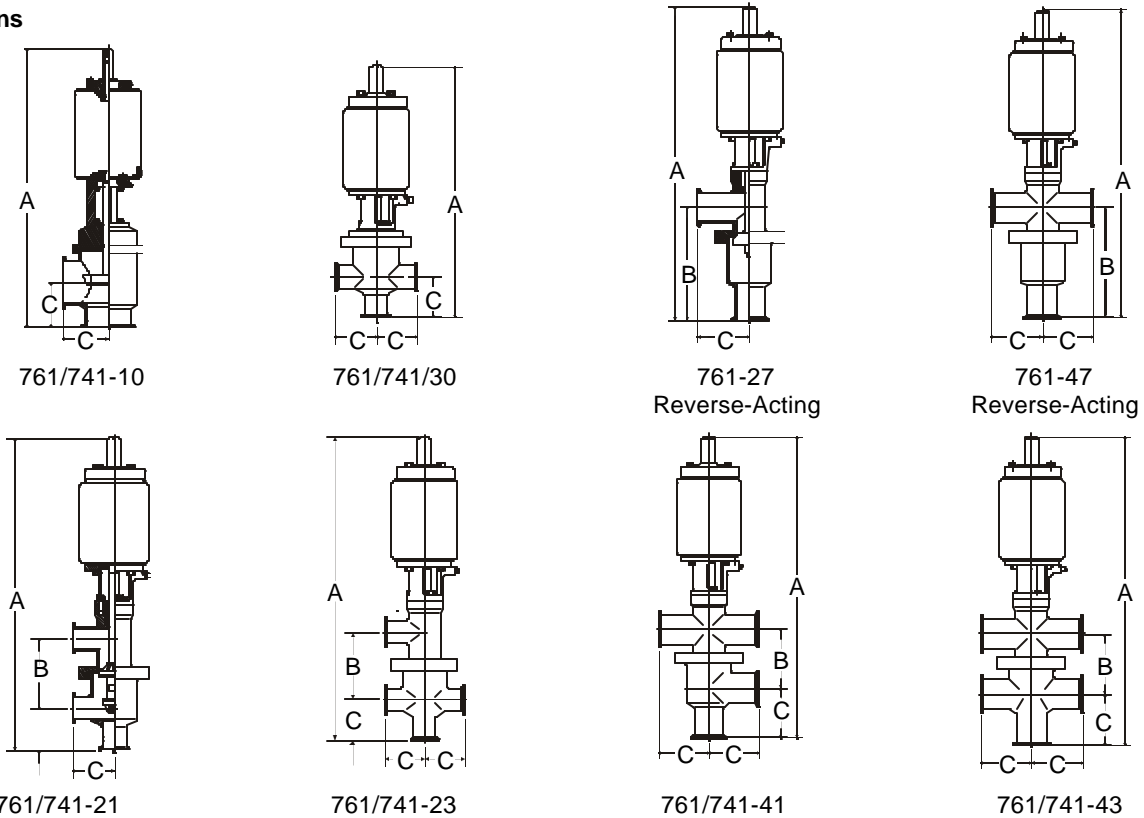

761 and 741 Shut-Off and Divert Valves

Valve Size (Tube OD)	A								B				C	
	Shut-Off Valves				Divert & Reverse-Acting* Shut-Off Valves				Divert Valves		Reverse Acting Shut-Off Valves			
	Short		Long		Short		Long		in	mm	in	mm	in	mm
	in	mm	in	mm	in	mm	in	mm	in	mm	in	mm	in	mm
1-inch	14.88	378.00	NA	NA	NA	NA	NA	NA	NA	NA	NA	NA	2.50	64.00
1½-inch	17.13	435.00	21.09	536.00	20.73	526.00	24.69	627.00	4.63	117.00	7.38	187.00	2.75	70.00
2-inch	17.63	448.00	21.56	548.00	21.19	538.00	25.16	639.00	4.13	105.00	7.63	194.00	3.50	89.00
2½-inch	17.56	446.00	21.53	547.00	21.85	555.00	25.81	656.00	4.50	114.00	8.00	203.00	3.50	89.00
3-inch	18.06	459.00	22.03	560.00	22.85	580.00	26.81	681.00	5.00	127.00	8.75	222.00	3.75	95.00
4-inch	24.97	634.00	31.09	790.00	31.00	787.00	37.09	942.00	6.00	152.00	NA	NA	4.00	102.00

* Reverse-acting NA in long stroke

** For valves with control housings, add the following to dimension A:

Short stroke sizes: 1-3" (25.4-76.2mm), **Add:** 19/16" (39.7mm)

Long stroke sizes: 1½ - 4" (38.1-101.6mm), **Add:** ¾" (19.0mm)

761 and 741 Shut-Off and Divert Valves with Variable and Mid-Position "80S" Actuator

Valve Size (Tube OD)	A				B		C	
	Shut-Off Valves		Divert Valves					
	Short		Short					
	in	mm	in	mm	in	mm	in	mm
1½-inch	17.75	451.00	23.31	592.00	4.62	117.00	2.75	70.00
2-inch	18.25	464.00	23.56	598.00	4.12	105.00	3.50	89.00
2½-inch	18.19	462.00	23.94	608.00	4.50	114.00	3.50	89.00
3-inch	18.69	475.00	24.69	627.00	5.00	127.00	3.75	95.00

Dimensions

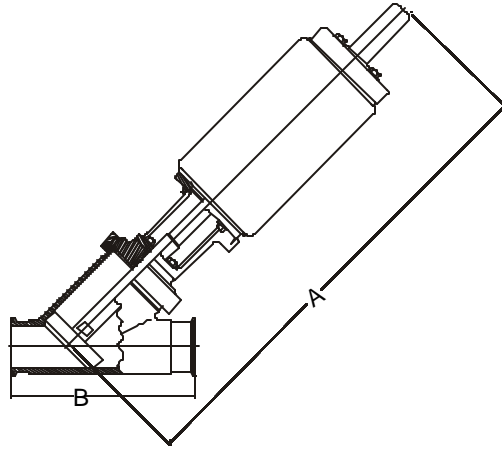

761-90 "Y" Body Shut-Off Valves

Valve Size (Tube OD)	A		B		C	
	in	mm	in	mm	in	mm
1½-inch	20.63	524.00	6.38	162.00	22.31	567.00
2-inch	22.38	568.00	7.88	200.00	24.63	625.00
2½-inch	22.94	583.00	9.25	235.00	25.44	646.00
3-inch	28.94	735.00	10.38	264.00	29.69	754.00
4-inch	32.13	816.00	12.63	321.00	32.88	835.00

*Column "C" represents dimension "A" with the addition of a control housing module.

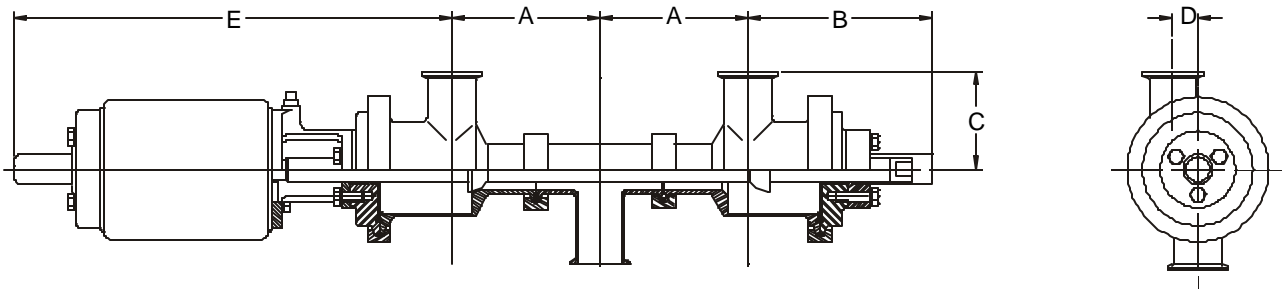

Reverse-Acting Divert Valves

761-21 MRALL (Left Hand Tangential)

761-21 MRARR (Right Hand Tangential)

Valve Size	A		B		C		D		E**	
	in	mm	in	mm	in	mm	in	mm	in	mm
2-inch	4.72	120.00			3.50	89.00	0.51	13.00	13.69	348.00
2½-inch	5.25	133.00	6.03	153.00	3.50	89.00	0.81	21.00	13.94	354.00
2½ HP	5.25	133.00	6.03	153.00	3.50	89.00	0.81	21.00	16.28	414.00
3 HP	5.75	146.00	6.28	159.00	3.75	95.00	0.81	21.00	18.88	479.00
4 HP	7.08	180.00	9.30	236.00	4.02	102.00	0.48	12.00	22.00	559.00

**For valves with control housings, add the following to dimension E:

1½-3" (38-76mm), add 19/16"(40mm)

Actuator function

- Pneumatic downward movement, spring return (NO).
- Pneumatic upward movement, spring return (NC).
- Pneumatic upward and downward movement (A/A),
- Actuator for intermediate position of the valve plug as option

Type 10 (Normally-Open)

Shut-off valve holding pressures — 70 psi air pressure supplied to actuator

Short Stroke Actuator (Standard*)				Long Stroke Actuator (Standard*)			Type 15
Size	Elastomer	"TR"	Stroke Length	Elastomer	"TR"	Stroke Length	20PSI
1-inch	105 psi	110 psi	0.75"	NA	NA	NA	50
1½-inch	120 psi	110 psi	1"	120 psi	110 psi	2"	26
2-inch	80 psi	70 psi	1"	125 psi	120 psi	2"	18
2½-inch	35 psi	20 psi	1"	60 psi	50 psi	2"	10
3-inch	20 psi	15 psi	1"	45 psi	40 psi	2"	7
4-inch	35 psi	20 psi	2"	40 psi	20 psi	4"	NA

* 4½" diameter actuator is standard on the 1"- 3" valves. A 6" diameter actuator is supplied with the 4" valve. A 4½" diameter actuator for the 4" valve is available upon request.

Type 10 (Normally-Open)

Shut-off valve holding pressures — 90 psi air pressure supplied to actuator

Short Stroke Actuator (Standard*)				Long Stroke Actuator (Standard*)		
Size	Elastomer	"TR"	Stroke Length	Elastomer	"TR"	Stroke Length
1-inch	105 psi	105 psi	0.75"	NA	NA	NA
1½-inch	150 psi	150 psi	1"	150 psi	150 psi	2"
2-inch	150 psi	150 psi	1"	150 psi	150 psi	2"
2½-inch	90 psi	80 psi	1"	120 psi	110 psi	2"
3-inch	70 psi	60 psi	1"	80 psi	70 psi	2"
4-inch	80 psi	75 psi	2"	100 psi	80 psi	4"

* 4½" diameter actuator is standard on the 1"-3" valves. A 6" diameter actuator is supplied with the 4" valve. A 4½" diameter actuator for the 4" valve is available upon request.

Type 20 (Normally-Closed)

Shut-off valve holding pressures (Standard)**

Short Stroke Actuator (Standard*)				Long Stroke Actuator (Standard*)			Type 25 Reverse Acting
Size	Elastomer	"TR"	Stroke Length	Elastomer	"TR"	Stroke Length	psig
1-inch	105 psi	110 psi	0.75"	NA	NA	**	NA
1½-inch	140 psi	140 psi	1"	140 psi	140 psi	2"	40
2-inch	90 psi	90 psi	1"	90 psi	90 psi	2"	25
2½-inch	55 psi	55 psi	1"	60 psi	55 psi	2"	15
3-inch	40 psi	40 psi	1"	32 psi	25 psi	2"	10
4-inch	65 psi	65 psi	2"	45 psi	40 psi	4"	NA

* 4½" diameter actuator is standard on the 1"-3" valves. A 6" diameter actuator is supplied with the 4" valve. The 6" diameter actuator is available, as a heavy duty option, for the 3" valve.

** On a standard actuator it takes 30 psi to offset the spring force when fully extended and 60 psi to fully compress the spring.

Type 20 (Normally-Closed)

Optional "HP" high pressure actuator. (6" diameter actuator)

Short Stroke Actuator (Standard*)				Long Stroke Actuator (Standard*)		
Size	Elastomer	"TR"	Stroke Length	Elastomer	"TR"	Stroke Length
2½-inch	110 psi	110 psi	1"	115 psi	110 psi	2"
3-inch	95 psi	90 psi	1"	100 psi	95 psi	2"

Actuator Air Supply Specifications

See chart below for minimum air pressure requirements.
 Maximum air pressure is 100 psi (normal).
 Air volume required is identified by the length of the stroke.

Valve Size	Stroke (in.)	Volume (cu. in.)
1-inch	0.75	11.1
1 1/2 - 3-inch short stroke	1	14.80
1 1/2 - 3-inch long stroke	2	29.50
4-inch short stroke HP	2	50.00
4-inch long stroke HP	4	95.00
Type 15 diaphragm	1	18.00

Lubricated air is not required. Filtered air and a pressure regulator valve are required.

Additional Holding Pressure

Additional air supply must be relieved when product pressure is not present. Failure to do so will result in pressure damage to the seat. When using additional air loading it should exceed the minimum required by no more that 3 to 5 psig.

Example: A customer has an application for a 3" valve that is required to hold 70 psi product pressure with an elastomer (Buna). The valve without an air assist will hold 40 psi. An additional holding force to overcome 30 psi (70 psi-40 psi) is needed. Since the ratio is 5:10 (air-to-product pressure ratio) a 15 psi air assist is needed.

Note: Since it takes 60 psi to fully stroke the valve without air assist, it will take 75 psi to open the example. (60 psi+15 psi)

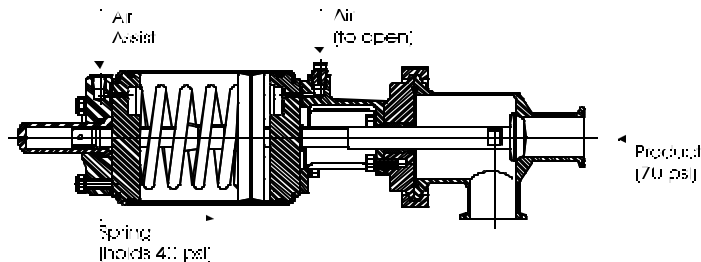

Valve Size	Air to Product Pressure Ratio	Max Recommended Air Assist	Max. Product Holding Pressure
1-inch	1:10	10	200
1 1/2-inch	1:10	5	200
2-inch	2:10	10	150
2 1/2-inch	3:10	20	100
3-inch	5:10	35	100
4-inch HP	4:10	25	100

Technical data

Max. product pressuredepends on valve specifications and size
(contact Alfa Laval)
Temperature range:200° F to 284° F (EPDM)
Air pressure:60-80 PSI

Materials

Product wetted steel parts:Stainless steel AISI 316L.
Finish:32 Ra Standard
Other steel parts:Stainless steel AISI 304.
Plug stem:Buna bonded or "TR" PTFE replaceable
Product wetted seals:Buna
Process connections:Tri-Clamp®

Options**Equipment**

- Process connections, weld, bevel seat
- Control and indication (Control Top or *ThinkTop*®)
- High pressure actuator for 2½" and 3" size
- Three Position Actuator (80)
- 20 Ra or 15 Ra ID surface finish
- Long stroke actuator

Material grades

- Industrial finish
- Molded elastomers of EPDM, SFY, or PTFE
- O-rings and seals of EPDM or SFY (Flouroelastomer)

Ordering

Please state the following when ordering:

- Size.
- Connections
- Valve body combination
- Actuator function, NC, NO or A/A
- Options.

PD 66365 US1 2001-10

The information contained herein is correct at the time of issue, but may be subject to change without prior notice.

How to contact Alfa Laval
Contact details for all countries
are continually updated on our website.
Please visit www.alfalaval.com to
access the information direct.



800.654.5635
www.csidesigns.com