



800.654.5635
www.csidesigns.com

Maintenance Manual

for 1 - 1½" sizes
SS316 Couplings



WARNING



Failure to follow Instructions and warnings can result in serious personal injury.

- Before installing, operating, or servicing any Dry Link assembly, read this Manual and all warning labels on the Dry Link products.
- Always wear safety glasses and foot protection.

If you need additional copies of the manual or have any questions about the safe operation of this tool, contact Dry Link, Inc. 574 Axminster Drive, Fenton, MO 63026, USA. Phone: (636) 349-2999, Fax: 636-349-7788

MAINTENANCE

INDEX

Operator Safety Instructions.....	2, 3
Main Seal Ring Replacements-	
Kits A & B; A-E, A-O, B-E & B-O.....	7, 8
O-ring Replacement - Kit D	9
Swivel Seal Replacement - Kit E	9
Locking Arm Replacement - Kit F.....	11
Flow Control Handle Replacement - Kit G	13
Coupler Disc Replacement - Kit H	13
Adapter Locking Cap Replacement - Kit I.....	15
Adapter Disc Replacement - Kit J.....	16
Adapter Cover and Side Panels Replacement - Kit K	18
Adapter Cover and Side Panels Replacement - Kit L.....	19

Hazard Identification

Definitions for identifying the various hazard levels shown on warning labels or to indicate proper safety procedures in this Manual are provided below.



This safety alert symbol indicates important safety messages on warning labels and in this manual. When you see this symbol be alert to the possibility of personal injury and carefully read and fully understand the message that follows.

DANGER

The use of the word "DANGER" signifies an immediate hazard with a likelihood of serious personal injury or death if instructions, including recommended precautions, are not followed.

WARNING

The use of the word "WARNING" signifies the presence of hazards or unsafe practices which could result in serious personal injury or death if instructions, including recommended precautions, are not followed.

CAUTION

The use of the word "CAUTION" signifies possible hazards or unsafe practices which could result in personal injury, product or property damage if instructions, including precautions, are not followed.

NOTICE

The use of the word "NOTICE" signifies special instructions which are important but not related to hazards.

⚠ WARNING

- Proper seal and wetted metal parts material selection is critical for safe operation. To assure maximum life for the service intended, use only those materials compatible with the fluids being handled. Please note material being supplied and make certain that it is suited for the intended service.
Failure to do so could result in serious personal injury, property damage, or leakage.

⚠ WARNING



- The Dry Link coupling assembly does not eliminate possible exposure to hazardous substances. Likewise, some product residue may appear on the disc faces. The conditions of handling and use are beyond our control, and we make no guarantee, and assume no liability for damages or injuries related to the use of this coupling assembly. It is the responsibility of the user to comply with all applicable federal, state, and local laws and regulations.
- Always employ proper safety precautions and handling techniques.
Failure to do so could result in serious personal injury, property damage, or leakage.

⚠ WARNING

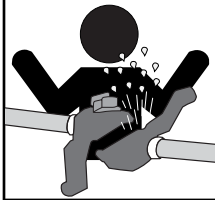

- Piping systems must always be depressurized and drained before attempting disassembly and removal of any Dry Link Couplings.
Failure to do so could result in serious personal injury, property damage, joint leakage or joint separation.

OPERATOR SAFETY INSTRUCTIONS

Always read and understand the operation sheet included with each unit and the individual operations detailed in this manual.

Although this hose coupling assembly is manufactured for dependable operation, it is impossible to anticipate that combination of circumstances which could result in an accident. The following instructions are recommended for proper maintenance of the coupling assembly. The operator is cautioned to always practice "Safety First" during each phase of use, including setup and maintenance of this unit.

- 1. Read and understand this operating manual before performing maintenance on this coupling assembly.** Become familiar with the unit's operation, applications and limitations. Be particularly aware of its specific hazards. Store this manual in a clean area and always at a readily available location. Additional copies at no charge can be obtained through written requests to Dry Link, Inc.
- 2. Depressurize the system.** Always depressurize the system before beginning any maintenance work on the hose coupling assembly. Failure to do so could result in serious personal injury, property damage or joint leakage.
- 3. Use recommended accessories.** Consult the Maintenance Manual. Use of improper accessories may be hazardous.
- 4. Maintain unit in top condition.** Regular inspection is recommended to detect any worn or damaged parts that could possibly cause a dangerous condition. Scheduled preventative maintenance should be done at regular intervals as determined by the application and frequency of use.
- 5. Wear proper apparel.** Always wear necessary safety attire before performing any maintenance on the hose coupling assembly.
- 6. Keep working environment clear at all times.** When maintaining this unit at elevated locations, keep area below clear of other personnel.

MAINTENANCE

DRY LINK® DRY DISCONNECT HOSE COUPLING ASSEMBLY

The Dry Link hose coupling assembly consists of coupler and adapter halves. When the coupler and adapter are joined, the disc halves in each come together and act in unison. A mechanical interlock restricts accidental opening. When separated, the disc halves provide instantaneous shut-off for the coupler and adapter providing virtually leak-free service.

When replacing the seals on Dry Link couplers and adapters, the chart below provides general service recommendations. Please be sure the materials being supplied for replacement are suited for the intended service.

Seal Material	General Service Recommendations
PTFE	Has outstanding resistance to chemical attack by most chemicals and solvents.
EPDM	Can be used for a variety of industrial chemicals, such as dilute acids and most ketones and alcohol. EPDM is not recommended for use with petroleum products.
Fluoroelastomer	Can be used for many oxidizing acids, petroleum oils, halogenated hydrocarbons, lubricants, hydraulic fluids or organic liquids.
CHEMRAZ	Similar to PTFE in chemical resistance. However, it has better resiliency.

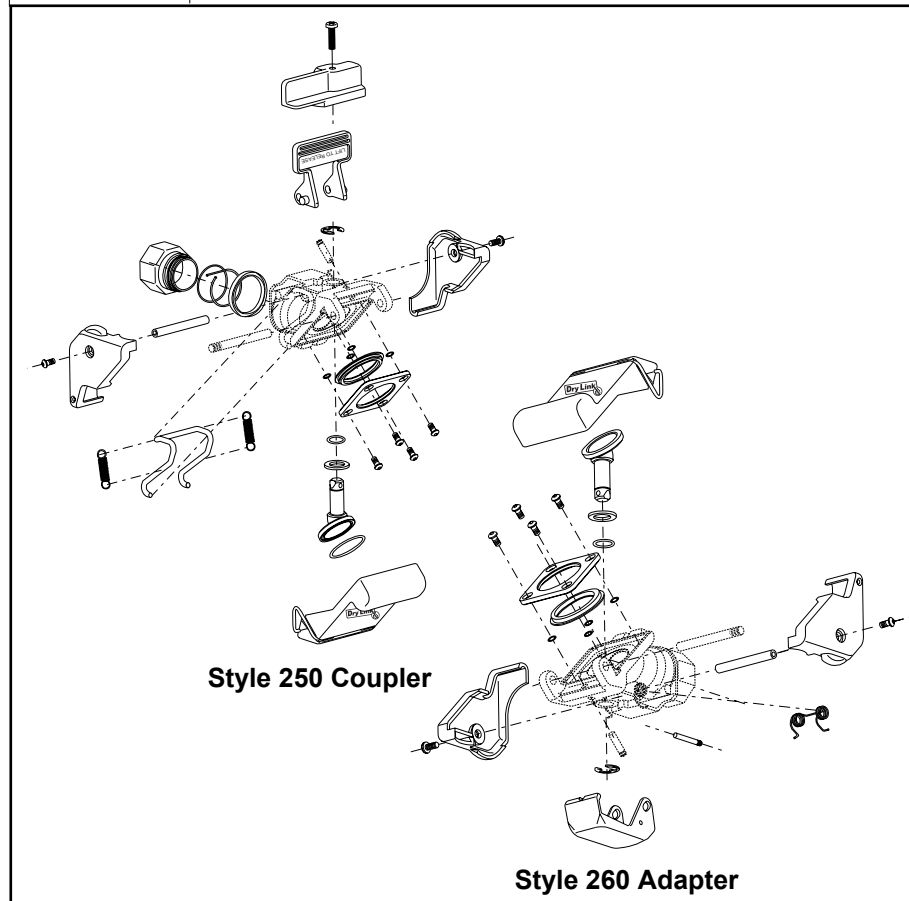

⚠ WARNING

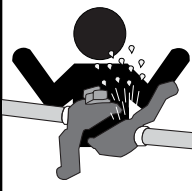

- Piping systems must always be depressurized and drained before attempting disassembly and removal of any Dry Link piping products.

Failure to do so could result in serious personal injury, property damage, joint leakage or joint separation.

**Main Seal Replacement
(For coupler and adapter units)**

Kits A, A-E, A-O, B-E & B-O

Note: To replace the main seal, you will need a 1/8" allen wrench & a special Seal installation Tool from Dry Link.

REMOVING SEAL

⚠ WARNING



- The Dry Link coupling assembly does not eliminate possible exposure to hazardous substances. Likewise, some product residue may appear on the disc faces. The conditions of handling and use are beyond our control, and we make no guarantee, and assume no liability for damages or injuries related to the use of this coupling assembly. It is the responsibility of the user to comply with all applicable federal, state, and local laws and regulations.
- Always employ proper safety precautions and handling techniques.

Failure to do so could result in serious personal injury, property damage, or leakage.



1. After depressurizing the system, remove the four socket head cap screws using the proper allen wrench.

MAINTENANCE



2. **Adapter:** Open the adapter disc by holding the hinged adapter stem locking cap down and turning the disc stem pin.

Coupler: Open the coupler disc by holding down the locking arm and turning the handle.



3. Pull the metal ring away from the body, and remove the PTFE seal from the metal ring.

4. If so required, remove the four optional washer-like spacers from the corners of the body face.

MAIN SEAL REPLACEMENT

⚠ WARNING

- Proper seal and wetted material selection is critical for safe operation. When changing the main seal material (i.e. from EPDM to PTFE) be sure the stem seal material is compatible (see Kits H & J).

Failure to do so could result in serious personal injury, property damage, or leakage.

The seal installation tool must be ordered separately from Dry Link, inc.



1. Clean the disc and body by wiping all sealing surfaces with a clean cloth. Be sure that no residue remains on the disc faces.

MAINTENANCE



2. Fully close the disc. Partially press the seal ring assembly over the seal mandrel. For PTFE Seal Kits: the seal ring assembly consists of the metal coupler seal retaining ring with the PTFE main seal inserted. The wide side of the PTFE main seal should be seated at the bottom of the cavity facing the disc.

3. On units originally equipped with four spacers, clean the four spot faced holes and place one new spacer into each.



4. Install the seal ring assembly into the seal cavity around the disc by aligning the seal installation mandrel with the disc and pressing the seal ring into place with the seal installation sleeve (Installation sleeve available from Dry Link.)



5. Re-install and tighten the screws with the proper allen wrench.

MAINTENANCE

PTFE Main Seal Replacement Kit (For coupler only)

Kit A

Kit Item No.	No. Per Kit	Part Description
AT1	1	Spring-energized PTFE Main Seal
AT2	1	Coupler Seal Retaining Ring
AT3	1	Coupler Main Seal O-ring
AT4	4	Socket Head Cap Screws
AT5	4	Spacers*

*Used only with units originally equipped with spacers.

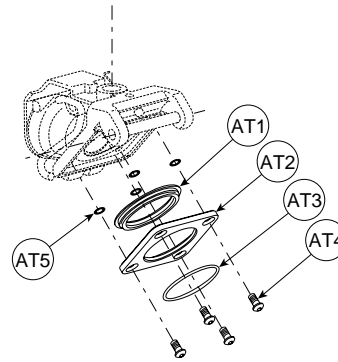

PTFE Main Seal Replacement Kit (For adapter only)

Kit B

Kit Item No.	No. Per Kit	Part Description
BT1	1	Spring-energized PTFE Main Seal
BT2	1	Adapter Seal Retaining Ring
BT3	4	Socket Head Cap Screws
BT4	4	Spacers*

*Used only with units originally equipped with spacers.

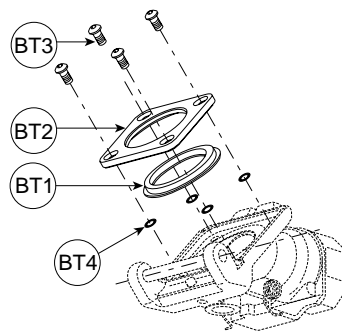

MAINTENANCE

EPDM and Fluoroelastomer Molded Main Seal Replacement Kit (For coupler only)

Kit A-E for EPDM & Kit A-O for Fluoroelastomer

Kit Item No.	No. Per Kit	Part Description
AM1-EPDM or AM1-Fluoroelastomer	1	Molded Main Seal - EPDM
	1	Molded Main Seal - Fluoroelastomer
AM2	4	Socket Head Cap Screws
AM3	4	Spacers*

*Used only with units originally equipped with spacers.

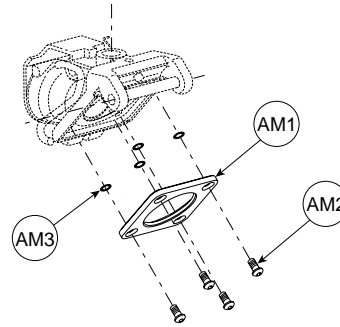

EPDM and Fluoroelastomer Molded Main Seal Replacement Kit (For adapter only)

Kit B-E for EPDM & Kit B-O for Fluoroelastomer

Kit Item No.	No. Per Kit	Part Description
BM1-EPDM or BM1-Fluoroelastomer	1	Molded Main Seal - EPDM
	1	Molded Main Seal - Fluoroelastomer
BM2	4	Socket Head Cap Screws
BM3	4	Spacers*

*Used only with units originally equipped with spacers.

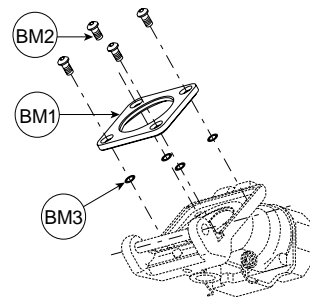

MAINTENANCE

O-ring Replacement (For coupler units)

Kit D

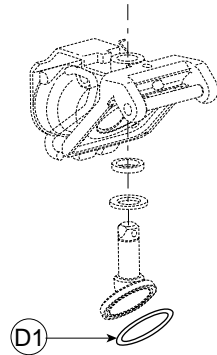

Kit Item No.	No. Per Kit	Part Description
D1	1	Coupler Disc Face O-ring

REMOVAL



1. Remove the o-ring with a pointed tool. Pry and lift the "O" ring completely out of the groove. **CAUTION: Permanent damage to the sealing surfaces may result if care is not taken during removal of the o-ring.**

INSTALLATION



2. Press the new o-ring into the groove, beginning at one point and slowly working the o-ring into the seating area. A properly installed o-ring will extend less than 1/32" above the disc face.

Swivel Seal Replacement (For coupler & adapter units)

Kit E

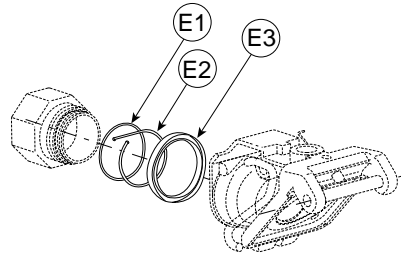

Kit Item No.	No. Per Kit	Part Description
E1	1	External Swivel Seal
E2	1	Swivel Spline
E3	1	Internal Swivel Spline

REMOVAL



1. Remove the coupler cover and side panels (See Kit L for instructions). Using pliers, grab the end of the spline and pull the spline completely out of the coupler body and discard.



2. Remove the swivel body and seals.

MAINTENANCE

SWIVEL INSTALLATION



1. Clean the coupler body and swivel body.



2. Using a silicone oil or grease, lightly lubricate the seals.



3. Place the internal swivel seal into the coupler body with the seal spring facing into the body. Take caution not to bend or fold the swivel seal.



4. Place the external swivel o-ring seal over the swivel body.



5. Using an anti-seize compound, lubricate the spline and spline groove on the swivel body.



6. Insert the swivel into the coupler body until it is fully seated. A slight rotation assists with this assembly.



7. Install the swivel spline by pushing the tapered end of the spline into the hole in the coupler body while turning the swivel body. Tapping the spline lightly with a hammer assists this installation. Take caution not to bend or kink the spline wire.

8. Replace the coupler cover and side panels.

**Locking Arm Replacement
(For coupler units)**

Kit F

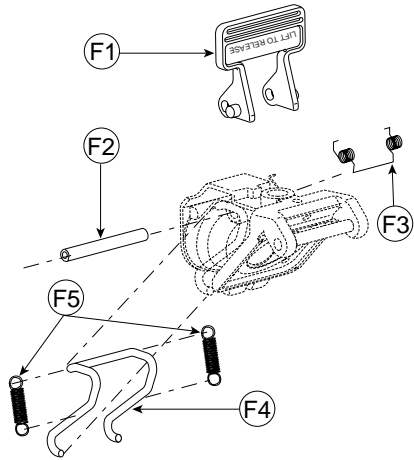

Kit Item No.	No. Per Kit	Part Description
F1	1	Locking Arm
F2	1	Locking Arm Standoff
F3	1	Locking Arm Spring
F4	1	Coupler Locking Bar
F5	2	Locking Bar Springs

REMOVAL

1. Remove the coupler cover and side panels. Remove the flow control handle (See Kits G and L for instructions).



2. Remove the locking arm standoff. Remove the locking arm spring and locking bar springs.



3. Remove the locking arm from the locking bar. This may be difficult and requires slight spreading of the open end of the locking bar and pushing it over the round lug on the locking arm.



4. Remove the locking bar from the coupler body by first rotating the open end of the locking bar back over the swivel end of the coupler body.



5. Twist and snake the bar out from the body opening. This may be difficult and will require a slight spreading of the open end of the locking bar.

MAINTENANCE

LOCKING ARM INSTALLATION



1. Reassemble the locking bar and locking arm. Ensure proper position. Lubricate the holes in the locking arm with an anti-seize compound.



2. Insert the locking arm spring into position.



3. Install the locking bar springs.



4. Complete assembly of the locking arm and locking bar by inserting the locking arm stand-off into the locking arm and through the corresponding hole in the coupler body. Check visually for proper assembly and function of the locking arm and locking bar.

5. Reassemble the flow control handle, coupler cover and the side panels (See Kits G and L for instructions).

Flow Control Handle Assembly Replacement (For coupler units)

Kit G

NOTE: The coupler handle assembly includes the coupler handle casting, the molded push button and the push button spring.

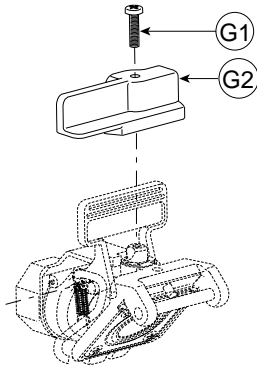

Kit Item No.	No. Per Kit	Part Description
G1	1	Pan Head Screw
G2	1	Coupler Lockout Handle Assembly

REMOVAL



1. Using the proper size hex wrench, remove the pan head screw.



2. Remove the coupler lockout handle.

MAINTENANCE

INSTALLATION



1. Reassemble the coupler lockout handle using the pan head screw. Do not over-tighten the screw. Test handle to ensure proper function of the unit.

Coupler Disc Replacement (For coupler units)

Kit H

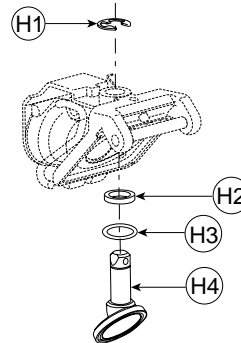

Kit Item No.	No. Per Kit	Part Description
H1	1	Retaining Ring
H2	1	Stem Seal
H3	1	O-ring - Perfluoroelastomer
H4	1	Coupler Disc

⚠ WARNING

Proper seal and wetted material selection is critical for safe operation. When changing the stem seal o-ring material (i.e. from EPDM to Kalrez) be sure the main seal material is compatible (see Kits)

MAINTENANCE

REMOVAL

1. Remove the flow control handle and the main seal (See Kits G and A for instructions).



2. With the disc rotated a half turn or 180° from the closed position, remove the retaining ring from the top of the disc stem and pull the disc out from the coupler body.



3. Remove the o-ring (or PTFE disc spacer, if equipped) and stem seal. Use caution not to scratch or score the coupler body in the disc seal area.



1. Clean the coupler body fully in the disc stem hole and the stem seal areas. Check for any corrosion or damage to the body in these areas.

INSTALLATION



1. Clean the coupler body fully in the disc stem hole and the stem seal areas. Check for any corrosion or damage to the body in these areas.



2. Apply an anti-seize compound into the stem hole in the coupler body. Anti-seize should **not** be present in the stem seal area. Use a silicone oil or grease to lubricate the stem seal and the stem seal area of the coupler body.



3. Put the o-ring over the disc stem. While holding the disc in the half turned position and taking caution not to scrape the disc edge against the coupler body, insert the disc stem into the stem seal and coupler body. Push the disc flush against the body.



4. While pushing the disc up into the body, insert the retaining ring into the slot on the disc stem. Rotate the disc several times to ensure proper installation.

5. Reassemble the flow control handle, main seal, coupler cover and the side panels.

MAINTENANCE

Disc Locking Arm Replacement (For adapter units)

Kit I

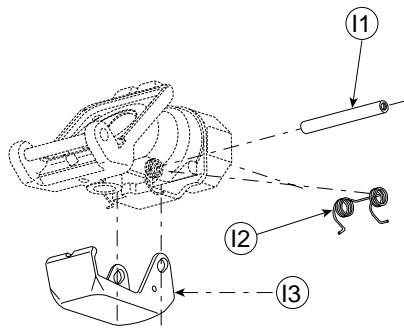

Kit Item No.	No. Per Kit	Part Description
I1	1	Locking Arm Standoff
I2	1	Locking Cap Spring
I3	1	Adapter Locking Cap

REMOVAL

1. Remove the adapter cover and side panels (See Kit K for instructions).



2. Pull the locking arm standoff out and remove the locking cap and locking cap spring.

INSTALLATION



1. Insert the locking cap spring into the proper area in the body. Hold the locking cap in position and put the hooked open ends of the locking cap spring into the small holes provided in the locking cap. Push the spring's center leg behind the boss on the adapter.

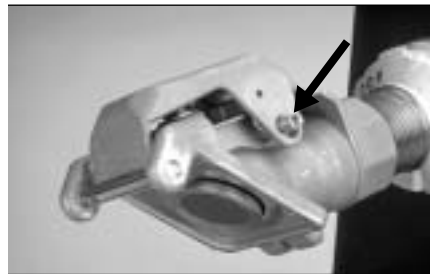

2. Insert the locking arm standoff into the locking cap. Install standoff through the locking cap spring loops to the hole in the adapter body and through the spring loops and back out the locking cap. Test locking arm to ensure proper assembly and function.

3. Reassemble the adapter cover and side panels.

MAINTENANCE

Adapter Disc Replacement (For adapter units)

Kit J

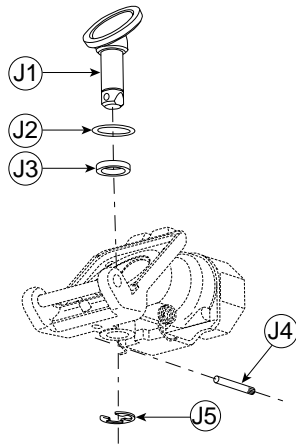

Kit Item No.	No. Per Kit	Part Description
J1	1	Adapter Disc
J2	1	O-ring - Perfluoroelastomer
J3	1	Stem Seal
J4	1	Disc Retainer Pin
J5	1	Retaining Ring

⚠ WARNING

- Proper seal and wetted material selection is critical for safe operation. When changing the stem seal o-ring material (i.e. from EPDM to Perfluoroelastomer) be sure the main seal material is compatible.

Failure to do so could result in serious personal injury, property damage, or leakage.

REMOVAL



1. Remove the adapter cover, side panels, locking cap and the main seal (See Kits I and K for instructions).



2. With the disc rotated a half turn or 180° from the closed position, remove the disc retaining pin from the top of the disc stem. If necessary, use a hammer and lightly tap the pin out.



3. With the disc rotated a half turn, remove the retaining ring from the top of the disc stem and pull the disc out from the coupler body.



4. Remove the o-ring (or PTFE disc spacer, if equipped) and stem seal. Use caution not to scratch or score the coupler body in the disc seal area.

INSTALLATION



1. Clean the body fully in the disc stem hole and the stem seal areas. Check for any corrosion, gauling or damage to the body in these areas.



2. Apply an anti-seize compound into the stem hole in the coupler body. Anti-seize should **not** be present in the stem seal area. Apply a light lubricant to the stem seal and the stem seal area of the coupler body.



MAINTENANCE



3. Put the o-ring over the disc stem. While holding the disc in the half turned position and taking caution not to scrape the disc edge against the coupler body, insert the disc stem into the stem seal and coupler body. Insert the disc until it is flush against the body.



4. While pushing the disc up into the body, insert the retaining ring into the slot on the disc stem. With the disc rotated in the half turn position, insert the disc retainer pin tapping with a hammer to insert the oversized grooved end on the pin into the hole in the disc stem. Rotate the disc several times to ensure proper function.



5. With the disc rotated a half turn or 180° from the closed position, insert the disc retaining pin into the stem hole. Use a hammer and lightly tap the pin into position.

6. Reassemble the adapter cover, side panels, locking cap and the main seal.

MAINTENANCE

Adapter Cover and Locking Bar Replacement (For adapter units)

Kit K

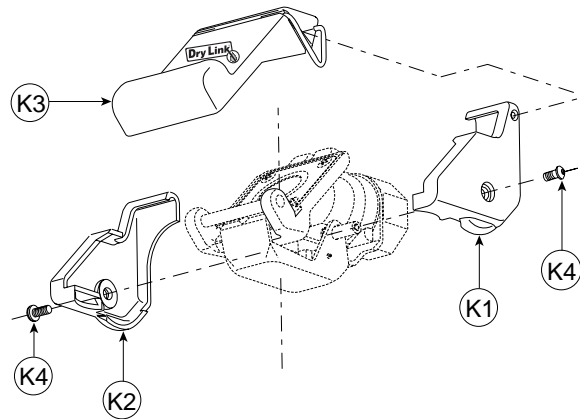

Kit Item No.	No. Per Kit	Part Description	Kit Item No.	No. Per Kit	Part Description
K1	1	Body Panel – Left half	K3	1	Adapter Cover and Wire Form
K2	1	Body Panel – Right half	K4	2	Socket Head Cap Screws

REMOVAL



1. Remove the adapter cover.



2. Remove the two socket head cap screws and the side panels. It is necessary to use an allen wrench on each screw. This will remove the first screw. It may be necessary to put the locking arm standoff in a soft jaw chuck to remove the second screw. Do not completely remove the locking arm standoff as this will disassemble the disc locking cap.

INSTALLATION



1. Align the side panels and install the screws. Tighten the screws with two wrenches.

2. Snap the cover wire form into the slot in the coupler cover.

3. Install the cover and check for proper alignment and function.

MAINTENANCE

Coupler Cover and Side Panels Replacement (For coupler units)

Kit L

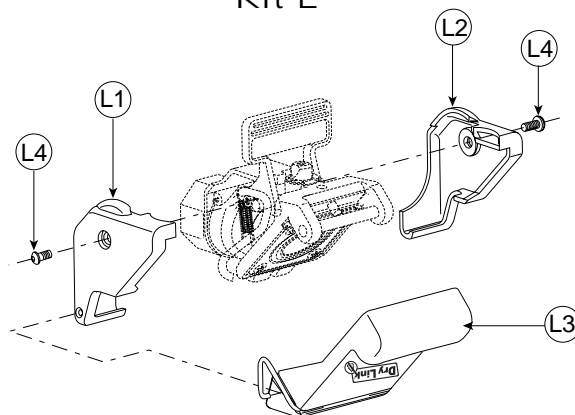

Kit Item No.	No. Per Kit	Part Description	Kit Item No.	No. Per Kit	Part Description
L1	1	Body Panel – Left half	L3	1	Coupler Cover and Wire Form
L2	1	Body Panel – Right half	L4	2	Socket Head Cap Screws

REMOVAL



1. Remove the coupler cover.



2. Remove the two socket head cap screws and the side panels. It is necessary to use an allen wrench on each screw. This will remove the first screw. It may be necessary to put the locking arm standoff in a soft jaw chuck to remove the second screw. Do not remove the locking arm stand-off completely as this will disassemble the disc locking cap.

INSTALLATION



1. Align the side panels and install the screws. Tighten the screws with two wrenches.

2. Snap the cover wire form into the slot in the coupler cover.

3. Install the cover and check for proper alignment and function.

A Video demo showing changing the Main Seal is available on our website www.drylink.com

Dry Link, Inc. 574 Axminister Drive. • Fenton, MO 63026 USA • Phone: (636) 349-2999 • FAX: (636) 349-7788 • www.drylink.com

