



# PRODUCT RECOVERY SYSTEM

www.csidesigns.com • www.csidesigns.com • www.csidesigns.com

CSI's Product Recovery System will increase your product yields and reduce CIP costs by recovering the residual product left behind in the lines after your food, beverage or pharmaceutical process.



## Features

- Sanitary clamp connections
- Available in tube sizes 1.5" through 4"
- Stocked in 316L
- Designed for use in standard sanitary tubing, fittings, sanitary hose, and full-port ball valves
- Optional pig detection and air control systems available
- Built-in pressure release for operator safety
- In-line design allows for installation into existing system
- One-piece solid, molded, urethane pig meets 3A and FDA requirements
- Designed for a variety of launch options

## Benefits

- Removes residual product from lines before it becomes a CIP problem
- Recovers valuable product for quick payback
- Reduces CIP chemical use
- Shortens CIP cycles

800.654.5635





# Product Recovery System



## DIMENSIONS

O.D. TUBE SIZE	LAUNCHER "A"	CATCHER "B"
1 1/2	8 1/2	9
2	10	9
2 1/2	12	9 1/2
3	13 1/8	13 5/8
4	18 1/2	13 5/8

Note: All dimensions in inches



- Pig can be launched from either run or branch of launcher in most applications
- Max operating pressure of 125 PSIG
- Optional catcher design available for water- push applications

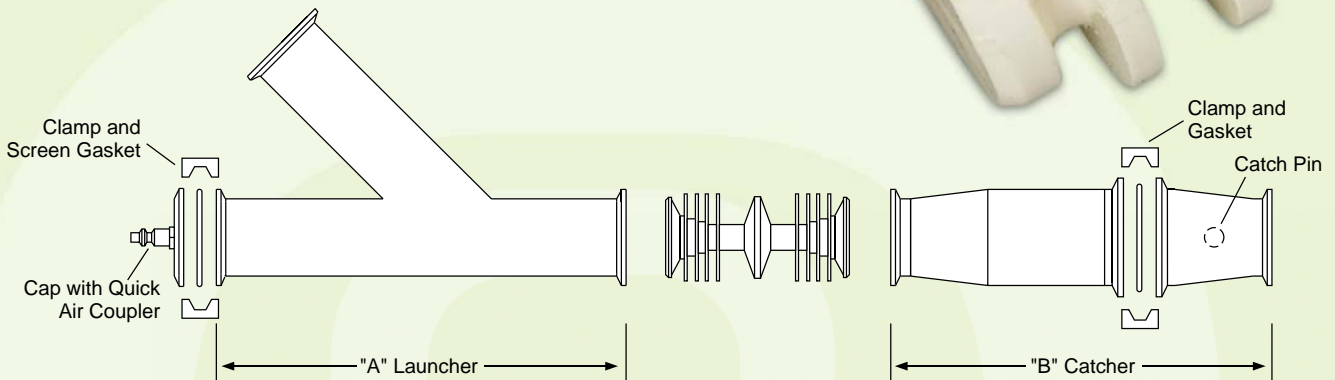

## PRODUCT RECOVERY SYSTEM BRINGING INNOVATION TO PROCESS SYSTEMS